



Table of Contents¹

Circles With and Without Coordinates

Module Overview	3
Topic A: Central and Inscribed Angles (G-C.A.2, G-C.A.3)	8
Lesson 1: Thales’ Theorem	10
Lesson 2: Circles, Chords, Diameters, and Their Relationships	21
Lesson 3: Rectangles Inscribed in Circles.....	34
Lesson 4: Experiments with Inscribed Angles.....	42
Lesson 5: Inscribed Angle Theorem and Its Application.....	53
Lesson 6: Unknown Angle Problems with Inscribed Angles in Circles.....	66
Topic B: Arcs and Sectors (G-C.A.1, G-C.A.2, G-C.B.5)	78
Lesson 7: The Angle Measure of an Arc.....	80
Lesson 8: Arcs and Chords	93
Lesson 9: Arc Length and Areas of Sectors.....	104
Lesson 10: Unknown Length and Area Problems	119
Mid-Module Assessment and Rubric	128
<i>Topics A through B (assessment 1 day, return, remediation, or further applications 1 day)</i>	
Topic C: Secants and Tangents (G-C.A.2, G-C.A.3)	143
Lesson 11: Properties of Tangents	144
Lesson 12: Tangent Segments	156
Lesson 13: The Inscribed Angle Alternate a Tangent Angle	168
Lesson 14: Secant Lines; Secant Lines that Meet Inside a Circle	180
Lesson 15: Secant Angle Theorem, Exterior Case.....	192
Lesson 16: Similar Triangles in Circle-Secant (or Circle-Secant-Tangent) Diagrams	204
Topic D: Equations for Circles and Their Tangents (G-GPE.A.1, G-GPE.B.4)	215
Lesson 17: Writing the Equation for a Circle	216

¹ Each lesson is ONE day, and ONE day is considered a 45-minute period.

Lesson 18: Recognizing Equations of Circles 227

Lesson 19: Equations for Tangent Lines to Circles 237

Topic E: Cyclic Quadrilaterals and Ptolemy’s Theorem (G-C.A.3) 246

Lesson 20: Cyclic Quadrilaterals 247

Lesson 21: Ptolemy’s Theorem..... 261

End-of-Module Assessment and Rubric 270

Topics C through D (assessment 1 day, return, remediation or further applications 1 day)

Geometry • Module 5

Circles With and Without Coordinates

OVERVIEW

With geometric intuition well established through Modules 1, 2, 3, and 4, students are now ready to explore the rich geometry of circles. This module brings together the ideas of similarity and congruence studied in Modules 1 and 2, the properties of length and area studied in Modules 3 and 4, and the work of geometric construction studied throughout the entire year. It also includes the specific properties of triangles, special quadrilaterals, parallel lines and transversals, and rigid motions established and built upon throughout this mathematical story.

This module's focus is on the possible geometric relationships between a pair of intersecting lines and a circle drawn on the page. If the lines are perpendicular and one passes through the center of the circle, then the relationship encompasses the perpendicular bisectors of chords in a circle and the association between a tangent line and a radius drawn to the point of contact. If the lines meet at a point on the circle, then the relationship involves inscribed angles. If the lines meet at the center of the circle, then the relationship involves central angles. If the lines meet at a different point inside the circle or at a point outside the circle, then the relationship includes the secant angle theorems and tangent angle theorems.

Topic A, through a hands-on activity, leads students first to Thales' theorem (an angle drawn from a diameter of a circle to a point on the circle is sure to be a right angle), then to possible converses of Thales' theorem, and finally to the general inscribed-central angle theorem. Students use this result to solve unknown angle problems. Through this work, students construct triangles and rectangles inscribed in circles and study their properties (**G-C.A.2, G-C.A.3**).

Topic B defines the measure of an arc and establishes results relating chord lengths and the measures of the arcs they subtend. Students build on their knowledge of circles from Module 2 and prove that all circles are similar. Students develop a formula for arc length in addition to a formula for the area of a sector and practice their skills solving unknown area problems (**G-C.A.1, G-C.A.2, G-C.B.5**).

In Topic C, students explore geometric relations in diagrams of two secant lines, or a secant and tangent line (possibly even two tangent lines), meeting a point inside or outside of a circle. They establish the secant angle theorems and tangent-secant angle theorems. By drawing auxiliary lines, students also notice similar triangles and thereby discover relationships between lengths of line segments appearing in these diagrams (**G-C.A.2, G-C.A.3, G-C.A.4**).

Topic D brings in coordinate geometry to establish the equation of a circle. Students solve problems to find the equations of specific tangent lines or the coordinates of specific points of contact. They also express circles via analytic equations (**G-GPE.A.1, G-GPE.B.4**).

The module concludes with Topic E focusing on the properties of quadrilaterals inscribed in circles and establishing Ptolemy's theorem. This result codifies the Pythagorean theorem, curious facts about triangles, properties of the regular pentagon, and trigonometric relationships. It serves as a final unifying flourish for students' year-long study of geometry (**G-C.A.3**).

Focus Standards

Understand and apply theorems about circles.

- G-C.A.1** Prove² that all circles are similar.
- G-C.A.2** Identify and describe relationships among inscribed angles, radii, and chords. *Include³ the relationship between central, inscribed, and circumscribed angles; inscribed angles on a diameter are right angles; the radius of a circle is perpendicular to the tangent where the radius intersects the circle.*
- G-C.A.3** Construct the inscribed and circumscribed circles of a triangle, and prove² properties of angles for a quadrilateral inscribed in a circle.

Find arc lengths and areas of sectors of circles.

- G-C.B.5** Derive using similarity the fact that the length of the arc intercepted by an angle is proportional to the radius, and define the radian measure of the angle as the constant of proportionality; derive the formula for the area of a sector.

Translate between the geometric description and the equation for a conic section.

- G-GPE.A.1** Derive the equation of a circle of given center and radius using the Pythagorean Theorem; complete the square to find the center and radius of a circle given by an equation.

Use coordinates to prove simple geometric theorems algebraically.

- G-GPE.B.4** Use coordinates to prove simple geometric theorems algebraically. *For example, prove or disprove that a figure defined by four given points in the coordinate plane is a rectangle; prove or disprove that the point $(1, \sqrt{3})$ lies on the circle centered at the origin and containing the point $(0, 2)$.*

Extension Standards

Understand and apply theorems about circles.

- G-C.A.4** (+) Construct a tangent line from a point outside a given circle to the circle.

Apply trigonometry to general triangles.

- G-SRT.D.9** (+) Derive the formula $A = 1/2 ab \sin(C)$ for the area of a triangle by drawing an auxiliary line from a vertex perpendicular to the opposite side.

² Prove *and apply* (in preparation for Regents Exams).

³ Include angles formed by secants (in preparation for Regents Exams).

Foundational Standards

Experiment with transformations in the plane.

- G-CO.A.3** Given a rectangle, parallelogram, trapezoid, or regular polygon, describe the rotations and reflections that carry it onto itself.
- G-CO.A.5** Given a geometric figure and a rotation, reflection, or translation, draw the transformed figure using, e.g., graph paper, tracing paper, or geometry software. Specify a sequence of transformations that will carry a given figure onto another.

Prove geometric theorems.

- G-CO.C.9** Prove theorems about lines and angles. *Theorems include: vertical angles are congruent; when a transversal crosses parallel lines, alternate interior angles are congruent, and corresponding angles are congruent; points on a perpendicular bisector of a line segment are exactly those equidistant from the segment's endpoints.*
- G-CO.C.10** Prove² theorems about triangles. *Theorems include: measures of interior angles of a triangle sum to 180° ; base angles of isosceles triangles are congruent; the segment joining midpoints of two sides of a triangle is parallel to the third side and half the length; the medians of a triangle meet at a point.*
- G-CO.C.11** Prove² theorems about parallelograms. *Theorems include: opposite sides are congruent, opposite angles are congruent, the diagonals of a parallelogram bisect each other, and conversely, rectangles are parallelograms with congruent diagonals.*

Make geometric constructions.

- G-CO.D.12** Make formal geometric constructions with a variety of tools and methods (compass and straightedge, string, reflective devices, paper folding, dynamic geometric software, etc.). *Copying a segment; copying an angle; bisecting a segment; bisecting an angle; constructing perpendicular lines, including the perpendicular bisector of a line segment; and constructing a line parallel to a given line through a point not on the line.*

Prove theorems involving similarity.

- G-SRT.B.5** Use congruence and similarity criteria for triangles to solve problems and to prove relationships in geometric figures.

Understand and apply the Pythagorean Theorem.

- 8.G.B.7** Apply the Pythagorean Theorem to determine unknown side lengths in right triangles in real-world and mathematical problems in two and three dimensions.
- 8.G.B.8** Apply the Pythagorean Theorem to find the distance between two points in a coordinate system.

Focus Standards for Mathematical Practice

- MP.1** **Make sense of problems and persevere in solving them.** Students solve a number of complex unknown angles and unknown area geometry problems, work to devise the geometric construction of given objects, and adapt established geometric results to new contexts and to new conclusions.
- MP.3** **Construct viable arguments and critique the reasoning of others.** Students must provide justification for the steps in geometric constructions and the reasoning in geometric proofs, as well as create their own proofs of results and their extensions.
- MP.7** **Look for and make use of structure.** Students must identify features within complex diagrams (e.g., similar triangles, parallel chords, and cyclic quadrilaterals) which provide insight as to how to move forward with their thinking.

Terminology

New or Recently Introduced Terms

- **Arc length** (The *length of an arc* is the circular distance around the arc.)
- **Central angle** (A *central angle* of a circle is an angle whose vertex is the center of a circle.)
- **Chord** (Given a circle C , let P and Q be points on C . The segment \overline{PQ} is called a *chord* of C .)
- **Cyclic quadrilateral** (A quadrilateral inscribed in a circle is called a *cyclic quadrilateral*.)
- **Inscribed angle** (An *inscribed angle* is an angle whose vertex is on a circle, and each side of the angle intersects the circle in another point.)
- **Inscribed polygon** (A polygon is *inscribed* in a circle if all vertices of the polygon lie on the circle.)
- **Secant line** (A *secant line* to a circle is a line that intersects a circle in exactly two points.)
- **Sector** (Let arc \widehat{AB} be an arc of a circle with center O and radius r . The union of the segments \overline{OP} , where P is any point on the arc \widehat{AB} , is called a *sector*. The arc \widehat{AB} is called the *arc of the sector*, and r is called its *radius*.)
- **Tangent line** (A *tangent line to a circle* is a line in the same plane that intersects the circle in one and only one point. This point is called the *point of tangency*.)

Familiar Terms and Symbols⁴

- Circle
- Diameter
- Radius

⁴ These are terms and symbols students have seen previously.

Suggested Tools and Representations

- Compass and straightedge
- Geometer's Sketchpad or Geogebra Software
- White and colored paper, markers

Assessment Summary

Assessment Type	Administered	Format	Standards Addressed
Mid-Module Assessment Task	After Topic B	Constructed response with rubric	G-C.A.1, G-C.A.2, G-C.A.3, G-C.B.5
End-of-Module Assessment Task	After Topic D	Constructed response with rubric	G-C.A.1, G-C.A.2, G-C.A.3, G-GPE.A.1, G-GPE.B.4



Topic A:

Central and Inscribed Angles

G-C.A.2, G-C.A.3

Focus Standards:	G-C.A.2	Identify and describe relationships among inscribed angles, radii, and chords. <i>Include the relationship between central, inscribed, and circumscribed angles; inscribed angles on a diameter are right angles; the radius of a circle is perpendicular to the tangent where the radius intersects the circle.</i>
	G-C.A.3	Construct the inscribed and circumscribed circles of a triangle, and prove properties of angles for a quadrilateral inscribed in a circle.
Instructional Days:	6	
	Lesson 1:	Thales' Theorem (E) ¹
	Lesson 2:	Circles, Chords, Diameters, and Their Relationships (P)
	Lesson 3:	Rectangles Inscribed in Circles (E)
	Lesson 4:	Experiments with Inscribed Angles (E)
	Lesson 5:	Inscribed Angle Theorem and its Applications (E)
	Lesson 6:	Unknown Angle Problems with Inscribed Angles in Circles (E)

The module begins with students exploring Thales' theorem. The first activity is a paper pushing discovery exercise where students push angles of triangles and trapezoids through a segment of fixed length to discover arcs of a circle (**G-C.A.2**). Students revisit the terms *diameter* and *radius* and are introduced to the terms *central angle* and *inscribed angle*. Lesson 2 begins the study of inscribed angles, which is the focus of this module. In this lesson, students study the relationships between circles and their diameters and between circles and their chords. Through the use of proofs (**G-C.A.2**), students realize that the perpendicular bisector of a chord contains the center. They also realize that the diameter is the longest chord, and congruent chords are equidistant from the center. Lesson 3 continues the study of inscribed angles by having students use a compass and straight edge to inscribe a rectangle in a circle (**G-C.A.3**). They then study the similarities of circles and the properties of other polygons that allow certain polygons to be inscribed in circles. Inscribed angles are compared to central angles in the same arcs in Lesson 4 with students using trapezoids and a paper pushing exercise similar to that of Lesson 1 to understand the difference between a major and minor arc. Students then explore inscribed and central angles and use repeated patterns (MP.7) to realize that the

¹ Lesson Structure Key: P-Problem Set Lesson, M-Modeling Cycle Lesson, E-Exploration Lesson, S-Socratic Lesson

measure of a central angle is double the angle inscribed in the same arc. In Lesson 5, students are introduced to the inscribed angle theorem, but they are only introduced to inscribed angles that are not obtuse. Students prove that inscribed angles are half the angle measure of the arcs they subtend. Lesson 6 completes the study of the inscribed angle theorem as students use their knowledge of chords, radii, diameters, central angles, and inscribed angles to persevere in solving a variety of unknown angle problems (MP.1). Throughout this module, students perform activities and constructions to enhance their understanding of the concepts studied. Through the use of proofs (MP.3 and concepts previously studied), students arrive at new theorems and definitions.



Lesson 1: Thales' Theorem

Student Outcomes

- Using observations from a *pushing* puzzle, explore the converse of *Thales' theorem*: If $\triangle ABC$ is a right triangle, then A , B , and C are three distinct points on a circle with \overline{AC} a diameter.
- Prove the statement of *Thales' theorem*: If A , B , and C are three different points on a circle with \overline{AC} a diameter, then $\angle ABC$ is a right angle.

Lesson Notes

Every lesson in this module is about an overlay of two intersecting lines and a circle. This will be pointed out to students later in the module, but keep this in mind as you are presenting lessons.

In this lesson, students investigate what some say is the oldest recorded result, with proof, in the history of geometry – Thales' theorem, attributed to Thales of Miletus (c. 624-c. 546 BCE), about 300 years before Euclid. Beginning with a simple experiment, students explore the converse of Thales' theorem. This motivates the statement of Thales' theorem, which students then prove using known properties of rectangles from Module 1.

Classwork

Opening

Students explore the converse of Thales's theorem with a *pushing* puzzle. Give each student a sheet of plain white paper, a sheet of colored cardstock, and a colored pen. Provide several minutes for the initial exploration before engaging students in a discussion of their observations and inferences.

Opening Exercise (5 minutes)

Opening Exercise

- Mark points A and B on the sheet of white paper provided by your teacher.
- Take the colored paper provided, and "push" that paper up between points A and B on the white sheet.
- Mark on the white paper the location of the corner of the colored paper, using a different color than black. Mark that point C . See the example below.

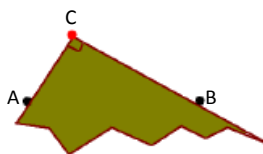

Scaffolding:

- For students with eye-hand coordination or visualization problems, model the Opening Exercise as a class, and then provide students with a copy of the work to complete the exploration.
- For advanced learners, explain the paper pushing puzzle, and let them come up with a hypothesis on what they are creating and how they can prove it without seeing questions.

MP.7
&
MP.8

- d. Do this again, pushing the corner of the colored paper up between the black points but at a different angle. Again, mark the location of the corner. Mark this point D .
- e. Do this again and then again, multiple times. Continue to label the points. What curve do the colored points (C, D, \dots) seem to trace?

Discussion (8 minutes)

- What curve do the colored points (C, D, \dots) seem to trace?
 - They seem to trace a semicircle.
- If that is the case, where might the center of that semicircle be?
 - The midpoint of the line segment connecting points A and B on the white paper will be the center point of the semicircle.
- What would the radius of this semicircle be?
 - The radius is half the distance between points A and B (or the distance between point A and the midpoint of the segment joining points A and B).
- Can we prove that the marked points created by the corner of the colored paper do indeed lie on a circle? What would we need to show? Have students do a 30-second Quick Write, and then share as a whole class.
 - We need to show that each marked point is the same distance from the midpoint of the line segment connecting the original points A and B .

Exploratory Challenge (12 minutes)

Allow students to come up with suggestions for **how** to prove that each marked point from the Opening Exercise is the same distance from the midpoint of the line segment connecting the original points A and B . Then offer the following approach.

- Have students draw the right triangle formed by the line segment between the two original points A and B and any one of the colored points (C, D, \dots) created at the corner of the colored paper; then construct a rotated copy of that triangle underneath it. A sample drawing might be as follows:

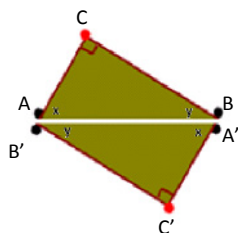

Allow students to read the question posed and have a few minutes to think independently and then share thoughts with an elbow partner. Lead students through the questions below.

It may be helpful to have students construct the argument outlined in Steps (a)-(b) below several times for different points on the same diagram. The idea behind the proof is that no matter which colored point is chosen, the distance from that colored point to the midpoint of the segment between points A and B must be the same as the distance from any other colored point to that midpoint.

Exploratory Challenge

Choose one of the colored points (C, D, \dots) that you marked. Draw the right triangle formed by the line segment connecting the original two points A and B and that colored point. Draw a rotated copy of the triangle underneath it.

Label the acute angles in the original triangle as x and y , and label the corresponding angles in the rotated triangle the same.

Todd says $ABCC'$ is a rectangle. Maryam says $ABCC'$ is a quadrilateral, but she's not sure it's a rectangle. Todd is right but doesn't know how to explain himself to Maryam. Can you help him out?

- a. What composite figure is formed by the two triangles? How would you prove it?

A rectangle is formed. We need to show that all four angles measure 90° .

- i. What is the sum of x and y ? Why?

90° ; the sum of the acute angles in any right triangle is 90° .

- ii. How do we know that the figure whose vertices are the colored points (C, D, \dots) and points A and B is a rectangle?

All four angles measure 90° . The colored points (C, D, \dots) are constructed as right angles, and the angle at points A and B measures $x + y$, which is 90° .

- b. Draw the two diagonals of the rectangle. Where is the midpoint of the segment connecting the two original points A and B ? Why?

The midpoint of the segment connecting points A and B is the intersection of the diagonals of the rectangle because the diagonals of a rectangle are congruent and bisect each other.

- c. Label the intersection of the diagonals as point P . How does the distance from point P to a colored point (C, D, \dots) compare to the distance from P to points A and B ?

The distances from P to each of the points are equal.

- d. Choose another colored point, and construct a rectangle using the same process you followed before. Draw the two diagonals of the new rectangle. How do the diagonals of the new and old rectangle compare? How do you know?

One diagonal is the same (the one between points A and B), but the other is different since it is between the new colored point and its image under a rotation. The new diagonals intersect at the same point P because diagonals of a rectangle intersect at their midpoints, and the midpoint of the segment connecting points A and B has not changed. The distance from P to each colored point equals the distance from P to each original point A and B . By transitivity, the distance from P to the first colored point, C , equals the distance from P to the second colored point, D .

MP.3
&
MP.7

e. How does your drawing demonstrate that all the colored points you marked do indeed lie on a circle?

For any colored point, we can construct a rectangle with that colored point and the two original points, A and B , as vertices. The diagonals of this rectangle intersect at the same point P because diagonals intersect at their midpoints, and the midpoint of the diagonal between points A and B is P . The distance from P to that colored point equals the distance from P to points A and B . By transitivity, the distance from P to the first colored point, C , equals the distance from P to any other colored point.

By definition, a circle is the set of all points in the plane that are the same distance from a given center point. Therefore, each colored point on the drawing lies on the circle with center P and a radius equal to half the length of the original line segment joining points A and B .

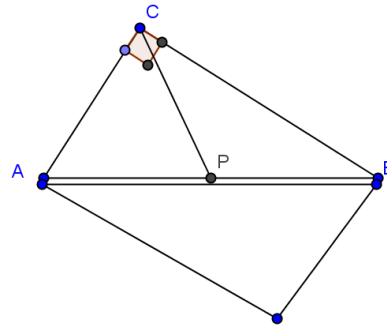

- Take a few minutes to write down what you have just discovered, and share that with your neighbor.
- We have proven the following theorem:
THEOREM: Given two points A and B , let point P be the midpoint between them. If C is a point such that $\angle ACB$ is right, then $BP = AP = CP$.

In particular, that means that point C is on a circle with center P and diameter \overline{AB} .

- This demonstrates the relationship between right triangles and circles.

THEOREM: If $\triangle ABC$ is a right triangle with $\angle C$ the right angle, then A, B , and C are three distinct points on a circle with \overline{AB} a diameter.

PROOF: If $\angle C$ is a right angle, and P is the midpoint between points A and B , then $BP = AP = CP$ implies that a circle with center P and radius AP contains the points A, B , and C .

- This last theorem is the converse of Thales' theorem, which is discussed below in Example 1.
- Review definitions previously encountered by students as stated in Relevant Vocabulary.

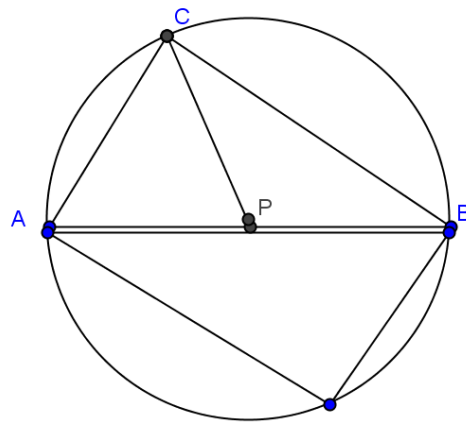

Relevant Vocabulary

CIRCLE: Given a point C in the plane and a number $r > 0$, the *circle* with center C and radius r is the set of all points in the plane that are distance r from the point C .

RADIUS: May refer either to the line segment joining the center of a circle with any point on that circle (a *radius*) or to the length of this line segment (the *radius*).

DIAMETER: May refer either to the segment that passes through the center of a circle whose endpoints lie on the circle (a *diameter*) or to the length of this line segment (the *diameter*).

CHORD: Given a circle C , and let P and Q be points on C . The segment \overline{PQ} is a *chord* of C .

CENTRAL ANGLE: A *central angle* of a circle is an angle whose vertex is the center of a circle.

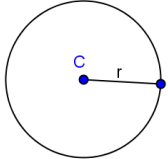
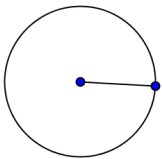
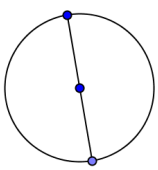
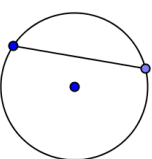
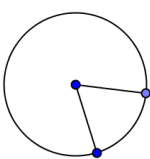
Circle	Radius	Diameter	Chord	Central Angle
				

Point out to students that $\angle x$ and $\angle y$ are examples of central angles.

Example 1 (8 minutes)

Share with students that they have just recreated the converse of what some say is the oldest recorded result, with proof, in the history of geometry –Thales’ theorem, attributed to Thales of Miletus (c. 624- c. 546 BCE), some three centuries before Euclid! See Wikipedia, for example, on why the theorem might be attributed to Thales although it was clearly known before him. http://en.wikipedia.org/wiki/Thales%27_Theorem.

Lead students through parts (a)–(b), and then let them struggle with a partner to determine a method to prove Thales’ theorem. If students are particularly struggling, give them the hint in the scaffold box. Once students have developed a strategy, lead the class through the remaining parts of this example.

Example 1

In the Exploratory Challenge, you proved the converse of a famous theorem in geometry. Thales’ theorem states: *If $A, B,$ and C are three distinct points on a circle and segment \overline{AB} is a diameter of the circle, then $\angle ACB$ is right.*

Notice that, in the proof in the Exploratory Challenge, you started with a right angle (the corner of the colored paper) and created a circle. With Thales’ theorem, you must start with the circle, and then create a right angle.

Prove Thales’ theorem.

- Draw circle P with distinct points $A, B,$ and C on the circle and diameter \overline{AB} . Prove that $\angle ACB$ is a right angle.
- Draw a third radius (\overline{PC}). What types of triangles are $\triangle APC$ and $\triangle BPC$? How do you know?

They are isosceles triangles. Both sides of each triangle are radii of circle P and are, therefore, of equal length.

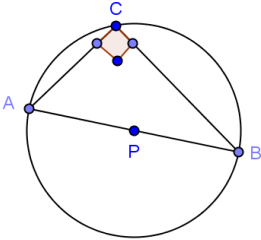

MP.1

c. Using the diagram that you just created, develop a strategy to prove Thales' theorem.

Look at each of the angle measures of the triangles, and see if we can prove $\angle ACB$ is 90° .

d. Label the base angles of $\triangle APC$ as b° and the bases of $\triangle BPC$ as a° . Express the measure of $\angle ACB$ in terms of a° and b° .

The measure of $\angle ACB$ is $a^\circ + b^\circ$.

e. How can the previous conclusion be used to prove that $\angle ACB$ is a right angle?

$2a + 2b = 180$ because the sum of the angle measures in a triangle is 180° . Then, $a + b = 90$, so $\angle ACB$ is a right angle.

Scaffolding:

- If students are struggling to develop a strategy to prove Thales' Theorem, give them this hint:
Draw a third radius, and use the result, also known to Thales, that the base angles of an isosceles triangle are congruent.

Exercises 1–2 (5 minutes)

Allow students to do Exercises 1–2 individually and then compare answers with a neighbor. Use this as a means of informal assessment, and offer help where needed.

Exercises 1–2

1. \overline{AB} is a diameter of the circle shown. The radius is 12.5 cm, and $AC = 7$ cm.

a. Find $m\angle C$.

90°

b. Find AB .

25 cm

c. Find BC .

24 cm

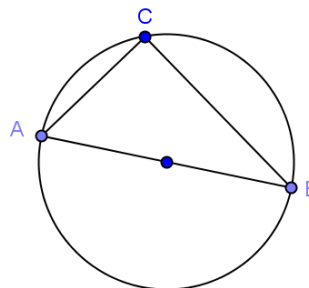

2. In the circle shown, \overline{BC} is a diameter with center A.

a. Find $m\angle DAB$.

144°

b. Find $m\angle BAE$.

128°

c. Find $m\angle DAE$.

88°

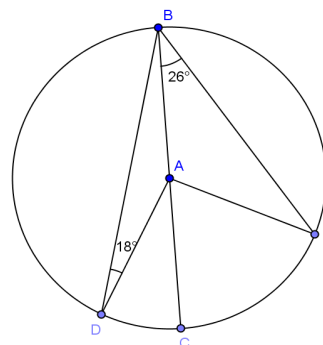

Closing (2 minutes)

Give students a few minutes to explain the prompt to their neighbor, and then call the class together and share. Use this time to informally assess understanding and clear up misconceptions.

- Explain to your neighbor the relationship that we have just discovered between a right triangle and a circle. Illustrate this with a picture.
 - *If $\triangle ABC$ is a right triangle and the right angle is $\angle C$, A , B , and C are distinct points on a circle and \overline{AB} is the diameter of the circle.*

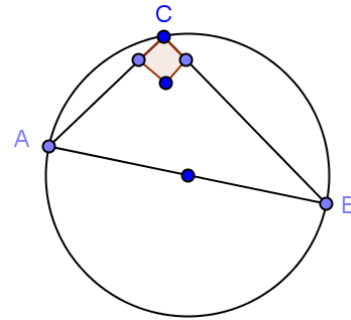

Lesson Summary

THEOREMS:

- **THALES' THEOREM:** If A , B , and C are three different points on a circle with \overline{AB} a diameter, then $\angle ACB$ is a right angle.
- **CONVERSE OF THALES' THEOREM:** If $\triangle ABC$ is a right triangle with $\angle C$ the right angle, then A , B , and C are three distinct points on a circle with \overline{AB} a diameter.
- Therefore, given distinct points A , B , and C on a circle, $\triangle ABC$ is a right triangle with $\angle C$ the right angle if and only if \overline{AB} is a diameter of the circle.
- Given two points A and B , let point P be the midpoint between them. If C is a point such that $\angle ACB$ is right, then $BP = AP = CP$.

Relevant Vocabulary

- **CIRCLE:** Given a point C in the plane and a number $r > 0$, the *circle* with center C and radius r is the set of all points in the plane that are distance r from the point C .
- **RADIUS:** May refer either to the line segment joining the center of a circle with any point on that circle (a *radius*) or to the length of this line segment (the *radius*).
- **DIAMETER:** May refer either to the segment that passes through the center of a circle whose endpoints lie on the circle (a *diameter*) or to the length of this line segment (the *diameter*).
- **CHORD:** Given a circle C , and let P and Q be points on C . The segment \overline{PQ} is called a *chord* of C .
- **CENTRAL ANGLE:** A *central angle* of a circle is an angle whose vertex is the center of a circle.

Exit Ticket (5 minutes)

Name _____

Date _____

Lesson 1: Thales' Theorem

Exit Ticket

Circle A is shown below.

1. Draw two diameters of the circle.
2. Identify the shape defined by the endpoints of the two diameters.
3. Explain why this shape will always result.

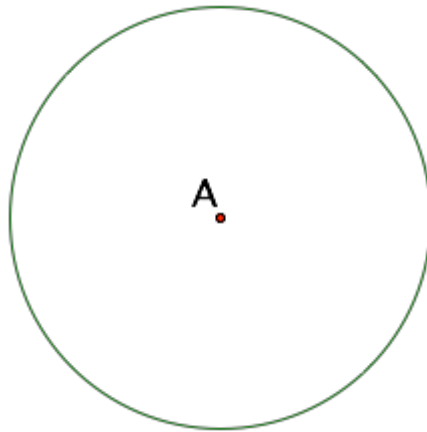

Exit Ticket Sample Solutions

Circle A is shown below.

1. Draw two diameters of the circle.
2. Identify the shape defined by the endpoints of the two diameters.
3. Explain why this shape will always result.

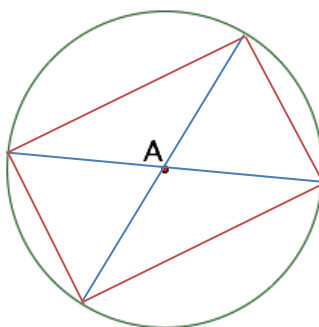

The shape defined by the endpoints of the two diameters will always form a rectangle. According to Thales' theorem, whenever an angle is drawn from the diameter of a circle to a point on its circumference, then the angle formed is a right angle. All four endpoints represent angles drawn from the diameter of the circle to a point on its circumference; therefore, each of the four angles is a right angle. The resulting quadrilateral will, therefore, be a rectangle by definition of rectangle.

Problem Set Sample Solutions

1. A , B , and C are three points on a circle, and angle ABC is a right angle. What's wrong with the picture below? Explain your reasoning.

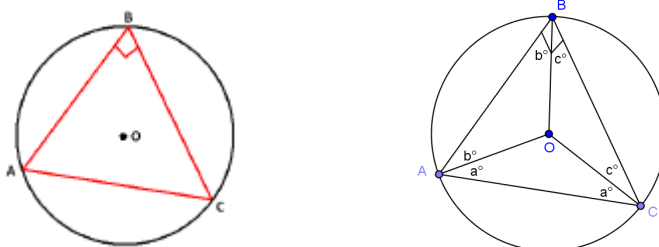

Draw in three radii (from O to each of the three triangle vertices), and label congruent base angles of each of the three resulting isosceles triangles. See diagram to see angle measures. In the "big" triangle ($\triangle ABC$), we get $2a + 2b + 2c = 180^\circ$. Using the distributive property and division, we obtain $2(a + b + c) = 180^\circ$ and $a + b + c = 90^\circ$. But we also have $90^\circ = \angle B = b + c$. Substitution results in $a + b + c = b + c$, giving a a value of 0° – a contradiction.

2. Show that there is something mathematically wrong with the picture below.

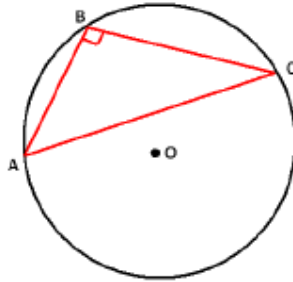

Draw three radii (\overline{OA} , \overline{OB} , and \overline{OC}). Label $\angle BAC$ as a and $\angle BCA$ as c . Also label $\angle OAC$ as x and $\angle OCA$ as x since $\triangle AOC$ is isosceles (both sides are radii). If $\angle ABC$ is a right angle (as indicated on the drawing), then $a + c = 90^\circ$. Since $\triangle AOB$ is isosceles, $\angle ABO = a + x$. Similarly, $\angle CBO = c + x$. Now adding the angles of $\triangle ABC$ results in $a + a + x + c + x + c = 180^\circ$. Using the distributive property and division, we obtain $a + c + x = 90^\circ$. Substitution takes us to $a + c = a + c + x$, which is a contradiction. Therefore, the figure above is mathematically impossible.

3. In the figure below, \overline{AB} is the diameter of a circle of radius 17 miles. If $BC = 30$ miles, what is AC ?

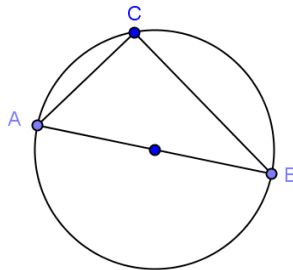

16 miles

4. In the figure below, O is the center of the circle, and \overline{AD} is a diameter.

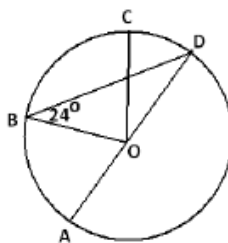

- a. Find $m\angle AOB$.

48°

- b. If $m\angle AOB : m\angle COD = 3 : 4$, what is $m\angle BOC$?

64°

5. \overline{PQ} is a diameter of a circle, and M is another point on the circle. The point R lies on the line \overline{MQ} such that $RM = MQ$. Show that $m\angle PRM = m\angle PQM$. (Hint: Draw a picture to help you explain your thinking!)

Since $RM = MQ$ (given), $m\angle RMP = m\angle QMP$ (both are right angles, $\angle QMP$ by Thales' theorem and $\angle RMP$ by the angle addition postulate), and $MP = MP$ (reflexive property), then $\triangle PRM \cong \triangle PQM$ by SAS. It follows that $\angle PRM \cong \angle PQM$ (corresponding sides of congruent triangles) and that $m\angle PRM = m\angle PQM$ (by definition of congruent angles).

6. Inscribe $\triangle ABC$ in a circle of diameter 1 such that \overline{AC} is a diameter. Explain why:

a. $\sin(\angle A) = BC$.

\overline{AC} is the hypotenuse, and $AC = 1$. Since sine is the ratio of the opposite side to the hypotenuse, $\sin(\angle A)$ will necessarily equal the length of the opposite side, that is, the length of \overline{BC} .

b. $\cos(\angle A) = AB$.

\overline{AC} is the hypotenuse, and $AC = 1$. Since cosine is the ratio of the adjacent side to the hypotenuse, $\cos(\angle A)$ will necessarily equal the length of the adjacent side, that is, the length of \overline{AB} .



Lesson 2: Circles, Chords, Diameters, and Their Relationships

Student Outcomes

- Identify the relationships between the diameters of a circle and other chords of the circle.

Lesson Notes

Students are asked to construct the perpendicular bisector of a line segment and draw conclusions about points on that bisector and the endpoints of the segment. They relate the construction to the theorem stating that any perpendicular bisector of a chord must pass through the center of the circle.

Classwork

Opening Exercise (4 minutes)

Opening Exercise

Construct the perpendicular bisector of line segment \overline{AB} below (as you did in Module 1).



Draw another line that bisects \overline{AB} but is not perpendicular to it.

List one similarity and one difference between the two bisectors.

Answers will vary. All points on the perpendicular bisector are equidistant from points A and B. Points on the other bisector are not equidistant from points A and B. The perpendicular bisector meets \overline{AB} at right angles. The other bisector meets at angles that are not congruent.

Scaffolding:

Post a diagram and display the steps to create a perpendicular bisector used in Lesson 4 of Module 1.

- Label the endpoints of the segment A and B .
- Draw circle A with center A and radius \overline{AB} .
- Draw circle B with center B and radius \overline{BA} .
- Label the points of intersection as C and D .
- Draw \overline{CD} .

You may wish to recall for students the definition of *equidistant*:

EQUIDISTANT: A point A is said to be *equidistant* from two different points B and C if $AB = AC$.

Points B and C can be replaced in the definition above with other figures (lines, etc.) as long as the distance to those figures is given meaning first. In this lesson, we will define the distance from the center of a circle to a chord. This definition will allow us to talk about the center of a circle as being equidistant from two chords.

Discussion (12 minutes)

Ask students independently or in groups to each draw chords and describe what they notice. Answers will vary depending on what each student drew.

Lead students to relate the perpendicular bisector of a line segment to the points on a circle, guiding them toward seeing the relationship between the perpendicular bisector of a chord and the center of a circle.

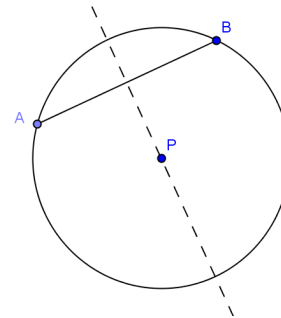

- Construct a circle of any radius, and identify the center as point P .
- Draw a chord, and label it \overline{AB} .
- Construct the perpendicular bisector of \overline{AB} .
- What do you notice about the perpendicular bisector of \overline{AB} ?
 - *It passes through point P , the center of the circle.*
- Draw another chord and label it \overline{CD} .
- Construct the perpendicular bisector of \overline{CD} .
- What do you notice about the perpendicular bisector of \overline{CD} ?
 - *It passes through point P , the center of the circle.*
- What can you say about the points on a circle in relation to the center of the circle?
 - *The center of the circle is equidistant from any two points on the circle.*
- Look at the circles, chords, and perpendicular bisectors created by your neighbors. What statement can you make about the perpendicular bisector of any chord of a circle? Why?
 - *It must contain the center of the circle. The center of the circle is equidistant from the two endpoints of the chord because they lie on the circle. Therefore, the center lies on the perpendicular bisector of the chord. That is, the perpendicular bisector contains the center.*
- How does this relate to the definition of the perpendicular bisector of a line segment?
 - *The set of all points equidistant from two given points (endpoints of a line segment) is precisely the set of all points on the perpendicular bisector of the line segment.*

MP.3 & MP.7

Scaffolding:

- Review the definition of *central angle* by posting a visual guide.
- A central angle of a circle is an angle whose vertex is the center of a circle.

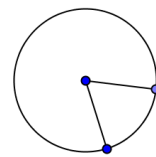

Exercises 1–6 (20 minutes)

Assign one proof to each group, and then jigsaw, share, and gallery walk as students present their work.

Exercises 1–6

1. Prove the theorem: *If a diameter of a circle bisects a chord, then it must be perpendicular to the chord.*

Draw a diagram similar to that shown below.

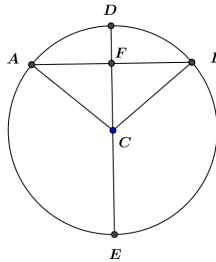

Given: Circle C with diameter \overline{DE} , chord \overline{AB} , and $AF = BF$.

Prove: $\overline{DE} \perp \overline{AB}$

$AF = BF$

Given

$FC = FC$

Reflexive property

$AC = BC$

Radii of the same circle are equal in measure

$\triangle AFC \cong \triangle BFC$

SSS

$m\angle AFC = m\angle BFC$

Corresponding angles of congruent triangles are equal in measure

$\angle AFC$ and $\angle BFC$ are right angles

Equal angles that form a linear pair each measure 90°

$\overline{DE} \perp \overline{AB}$

Definition of perpendicular lines

OR

$AF = BF$

Given

$AC = BC$

Radii of the same circle are equal in measure

$m\angle FAC = m\angle FBC$

Base angles of an isosceles are equal in measure

$\triangle AFC \cong \triangle BFC$

SAS

$m\angle AFC = m\angle BFC$

Corresponding angles of congruent triangles are equal in measure

$\angle AFC$ and $\angle BFC$ are right angles

Equal angles that form a linear pair each measure 90°

$\overline{DE} \perp \overline{AB}$

Definition of perpendicular lines

2. Prove the theorem: *If a diameter of a circle is perpendicular to a chord, then it bisects the chord.*

Use a diagram similar to that in Exercise 1 above.

Given: Circle C with diameter \overline{DE} , chord \overline{AB} , and $\overline{DE} \perp \overline{AB}$

Prove: \overline{DE} bisects \overline{AB}

$\overline{DE} \perp \overline{AB}$

Given

$\angle AFC$ and $\angle BFC$ are right angles

Definition of perpendicular lines

$\triangle AFC$ and $\triangle BFC$ are right triangles

Definition of right triangle

$\angle AFC \cong \angle BFC$

All right angles are congruent

$FC = FC$

Reflexive property

$AC = BC$

Radii of the same circle are equal in measure

$\triangle AFC \cong \triangle BFC$

HL

$AF = BF$

Corresponding sides of congruent triangles are equal in length

\overline{DE} bisects \overline{AB}

Definition of segment bisector

OR

$\overline{DE} \perp \overline{AB}$

Given

$\angle AFC$ and $\angle BFC$ are right angles

Definition of perpendicular lines

$\angle AFC \cong \angle BFC$

All right angles are congruent

$AC = BC$

Radii of the same circle are equal in measure

$m\angle FAC = m\angle FBC$

Base angles of an isosceles triangle are congruent

$m\angle ACF = m\angle BCF$

Two angles of triangle are equal in measure, so third angles are equal

$\triangle AFC \cong \triangle BFC$

ASA

$AF = BF$

Corresponding sides of congruent triangles are equal in length

\overline{DE} bisects \overline{AB}

Definition of segment bisector

3. The distance from the center of a circle to a chord is defined as the length of the perpendicular segment from the center to the chord. Note that, since this perpendicular segment may be extended to create a diameter of the circle, therefore, the segment also bisects the chord, as proved in Exercise 2 above.

Prove the theorem: *In a circle, if two chords are congruent, then the center is equidistant from the two chords.*

Use the diagram below.

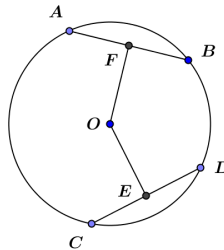

Given: Circle O with chords \overline{AB} and \overline{CD} ; $AB = CD$; F is the midpoint of \overline{AB} and E is the midpoint of \overline{CD} .

Prove: $OF = OE$

$AB = CD$

Given

$\overline{OF} \perp \overline{AB}$; $\overline{OE} \perp \overline{CD}$

If a diameter of a circle bisects a chord, then the diameter must be perpendicular to the chord.

$\angle AFO$ and $\angle DEO$ are right angles

Definition of perpendicular lines

$\triangle AFO$ and $\triangle DEO$ are right triangles

Definition of right triangle

E and F are midpoints of \overline{CD} and \overline{AB}

Given

$AF = DE$

$AB = CD$ and F and E are midpoints of \overline{AB} and \overline{CD}

$AO = DO$

All radii of a circle are equal in measure

$\triangle AFO \cong \triangle DEO$

HL

$OE = OF$

Corresponding sides of congruent triangles are equal in length

4. Prove the theorem: *In a circle, if the center is equidistant from two chords, then the two chords are congruent.*
Use the diagram below.

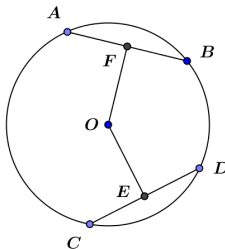

Given: Circle O with chords \overline{AB} and \overline{CD} ; $OF = OE$; F is the midpoint of \overline{AB} and E is the midpoint of \overline{CD}

Prove: $AB = CD$

$OF = OE$

Given

$\overline{OF} \perp \overline{AB}$; $\overline{OE} \perp \overline{CD}$

If a diameter of a circle bisects a chord, then it must be perpendicular to the chord.

$\angle AFO$ and $\angle DEO$ are right angles

Definition of perpendicular lines.

$\triangle AFO$ and $\triangle DEO$ are right triangles

Definition of right triangle.

$AO = DO$

All radii of a circle are equal in measure.

$\triangle AFO \cong \triangle DEO$

HL

$AF = DE$

Corresponding sides of congruent triangles are equal in length.

F is the midpoint of \overline{AB} , and E is the midpoint of \overline{CD}

Given

$AB = CD$

$AF = DE$ and F and E are midpoints of \overline{AB} and \overline{CD} .

5. A central angle defined by a chord is an angle whose vertex is the center of the circle and whose rays intersect the circle. The points at which the angle's rays intersect the circle form the endpoints of the chord defined by the central angle.

Prove the theorem: In a circle, congruent chords define central angles equal in measure.

Use the diagram below.

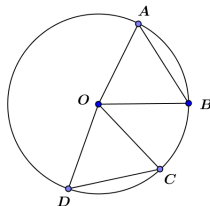

We are given that the two chords (\overline{AB} and \overline{CD}) are congruent. Since all radii of a circle are congruent, $\overline{AO} \cong \overline{BO} \cong \overline{CO} \cong \overline{DO}$. Therefore, $\triangle ABO \cong \triangle CDO$ by SSS. $\angle AOB \cong \angle COD$ since corresponding angles of congruent triangles are equal in measure.

6. Prove the theorem: In a circle, if two chords define central angles equal in measure, then they are congruent.

Using the diagram from Exercise 5 above, we now are given that $m\angle AOB = m\angle COD$. Since all radii of a circle are congruent, $\overline{AO} \cong \overline{BO} \cong \overline{CO} \cong \overline{DO}$. Therefore, $\triangle ABO \cong \triangle CDO$ by SAS. $\overline{AB} \cong \overline{CD}$ because corresponding sides of congruent triangles are congruent

Closing (4 minutes)

Have students write all they know to be true about the diagrams below. Bring the class together, go through the Lesson Summary, having students complete the list that they started, and discuss each point.

A reproducible version of the graphic organizer shown is included at the end of the lesson.

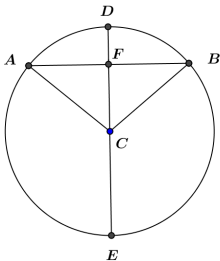
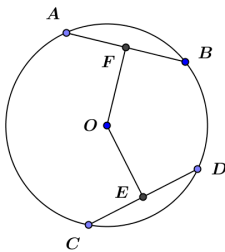
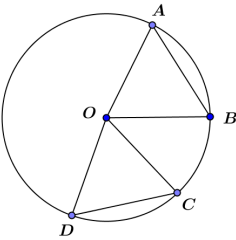
Diagram	Explanation of Diagram	Theorem or Relationship
	<p>Diameter of a circle bisecting a chord</p>	<p>If a diameter of a circle bisects a chord, then it must be perpendicular to the chord. If a diameter of a circle is perpendicular to a chord, then it bisects the chord.</p>
	<p>Two congruent chords equidistant from center</p>	<p>If two chords are congruent, then the center is equidistant from the two chords. If the center is equidistant from two chords, then the two chords are congruent.</p>
	<p>Congruent chords</p>	<p>Congruent chords define central angles equal in measure. If two chords define central angles equal in measure, then they are congruent.</p>

Lesson Summary**Theorems about chords and diameters in a circle and their converses**

- If a diameter of a circle bisects a chord, then it must be perpendicular to the chord.
- If a diameter of a circle is perpendicular to a chord, then it bisects the chord.
- If two chords are congruent, then the center is equidistant from the two chords.
- If the center is equidistant from two chords, then the two chords are congruent.
- Congruent chords define central angles equal in measure.
- If two chords define central angles equal in measure, then they are congruent.

Relevant Vocabulary

EQUIDISTANT: A point A is said to be *equidistant* from two different points B and C if $AB = AC$.

Exit Ticket (5 minutes)

Name _____

Date _____

Lesson 2: Circles, Chords, Diameters, and Their Relationships

Exit Ticket

1. Given circle A shown, $AF = AG$ and $BC = 22$. Find DE .

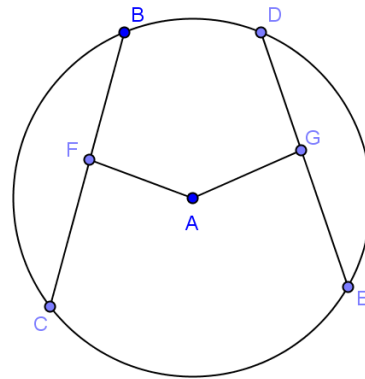

2. In the figure, circle P has a radius of 10. $\overline{AB} \perp \overline{DE}$.
- a. If $AB = 8$, what is the length of AC ?

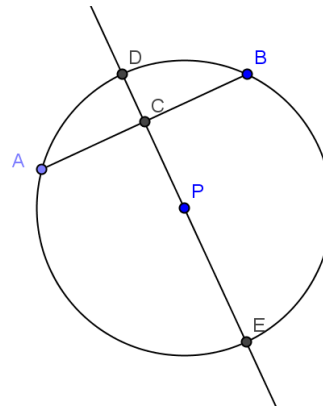

- b. If $DC = 2$, what is the length of AB ?

Exit Ticket Sample Solutions

1. Given circle A shown, $AF = AG$ and $BC = 22$. Find DE .

22

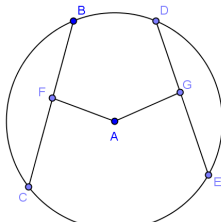

2. In the figure, circle P has a radius of 10. $\overline{AB} \perp \overline{DE}$.

a. If $AB = 8$, what is the length of AC ?

4

b. If $DC = 2$, what is the length of AB ?

12

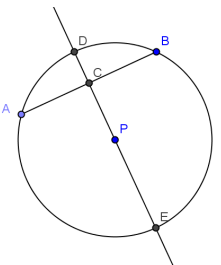

Problem Set Sample Solutions

1. In this drawing, $AB = 30$, $OM = 20$, and $ON = 18$. What is CN ?

$2\sqrt{301} (\approx 34.7)$

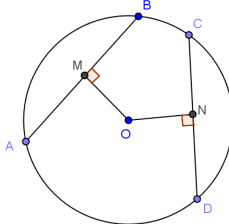

2. In the figure to the right, $\overline{AC} \perp \overline{BG}$ and $\overline{DF} \perp \overline{EG}$; $EF = 12$. Find AC .

24

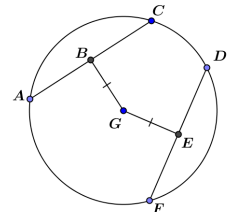

3. In the figure, $AC = 24$, and $DG = 13$. Find EG . Explain your work.

5 , $\triangle ABG$ is a right triangle with hypotenuse = radius = 13 and $AB = 12$, so $BG = 5$ by Pythagorean theorem. $BG = GE = 5$.

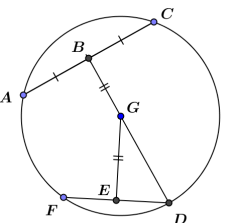

4. In the figure, $AB = 10$, $AC = 16$. Find DE .

4

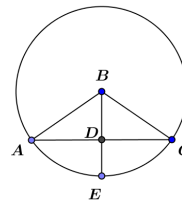

5. In the figure, $CF = 8$, and the two concentric circles have radii of 10 and 17. Find DE .

9

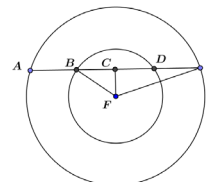

6. In the figure, the two circles have equal radii and intersect at points B and D . A and C are centers of the circles. $AC = 8$, and the radius of each circle is 5. $\overline{BD} \perp \overline{AC}$. Find BD . Explain your work.

6

$BA = BC = 5$ (radii)

$AG = GC = 4$

$BG = 3$ (Pythagorean theorem)

$BD = 6$

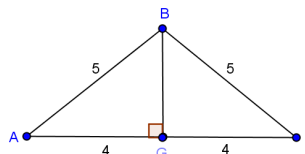
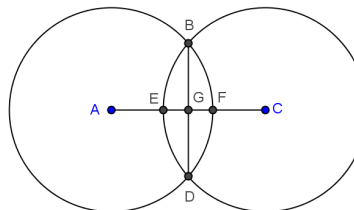

7. In the figure, the two concentric circles have radii of 6 and 14. Chord \overline{BF} of the larger circle intersects the smaller circle at C and E . $CE = 8$. $\overline{AD} \perp \overline{BF}$.

a. Find AD .

$2\sqrt{5}$

b. Find BF .

$8\sqrt{11}$

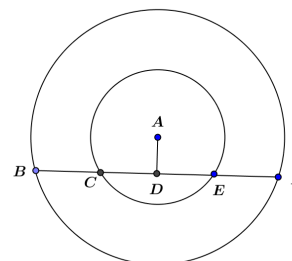

8. In the figure, A is the center of the circle, and $CB = CD$. Prove that \overline{AC} bisects $\angle BCD$.

Let \overline{AE} and \overline{AF} be perpendiculars from A to \overline{CB} and \overline{CD} , respectively.

$CB = CD$

Given

$AE = AF$

If two chords are congruent, then the center is equidistant from the two chords.

$AC = AC$

Reflexive property

$\angle CEA = \angle CFA = 90^\circ$

A line joining the center and the midpoint of a chord is perpendicular to the chord.

$\triangle CEA \cong \triangle CFA$

HL

$\angle ECA = \angle FCA$

Corresponding angles of congruent triangles are equal in measure.

\overline{AC} bisects $\angle BCD$

Definition of angle bisector

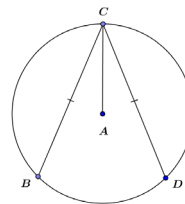

9. In class, we proved: *Congruent chords define central angles equal in measure.*

a. Give another proof of this theorem based on the properties of rotations. Use the figure from Exercise 5.

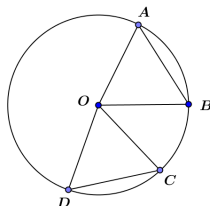

We are given that the two chords $(\overline{AB}$ and $\overline{CD})$ are congruent. Therefore, a rigid motion exists that carries \overline{AB} to \overline{CD} . The same rotation that carries \overline{AB} to \overline{CD} also carries \overline{AO} to \overline{CO} and \overline{BO} to \overline{DO} . The angle of rotation is the measure of $\angle AOC$, and the rotation is clockwise.

b. Give a rotation proof of the converse: *If two chords define central angles of the same measure, then they must be congruent.*

Using the same diagram, we are given that $\angle AOB \cong \angle COD$. Therefore, a rigid motion (a rotation) carries $\angle AOB$ to $\angle COD$. This same rotation carries \overline{AO} to \overline{CO} and \overline{BO} to \overline{DO} . The angle of rotation is the measure of $\angle AOC$, and the rotation is clockwise.

Graphic Organizer on Circles

Diagram	Explanation of Diagram	Theorem or Relationship



Lesson 3: Rectangles Inscribed in Circles

Student Outcomes

- Inscribe a rectangle in a circle.
- Understand the symmetries of *inscribed rectangles* across a diameter.

Lesson Notes

Have students use a compass and straightedge to locate the center of the circle provided. If necessary, remind students of their work in Module 1 on constructing a perpendicular to a segment and of their work in Lesson 1 in this module on Thales' theorem. Standards addressed with this lesson are **G-C.A.2** and **G-C.A.3**.

Classwork

Opening Exercise (9 minutes)

Students will follow the steps provided and use a compass and straightedge to find the center of a circle. This exercise reminds students about constructions previously studied that will be needed in this lesson and later in this module.

Opening Exercise

Using only a compass and straightedge, find the location of the center of the circle below. Follow the steps provided.

- Draw chord \overline{AB} .
- Construct a chord perpendicular to \overline{AB} at endpoint B .
- Mark the point of intersection of the perpendicular chord and the circle as point C .
- \overline{AC} is a diameter of the circle. Construct a second diameter in the same way.
- Where the two diameters meet is the center of the circle.

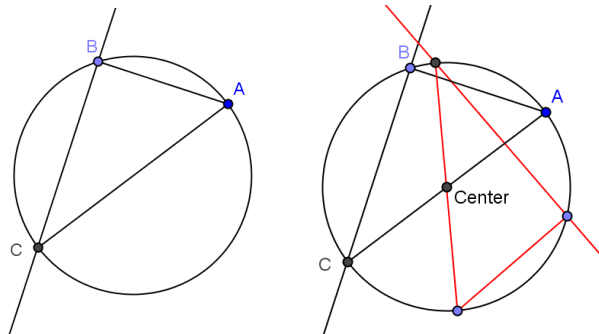

Scaffolding:

Display steps to construct a perpendicular line at a point.

- Draw a segment through the point, and using a compass mark a point equidistant on each side of the point.
- Label the endpoints of the segment A and B .
- Draw circle A with center A and radius \overline{AB} .
- Draw circle B with center B and radius \overline{BA} .
- Label the points of intersection as C and D .
- Draw \overline{CD} .
- For students struggling with constructions due to eye-hand coordination or fine motor difficulties, provide set squares to construct perpendicular lines and segments.
- For advanced learners, give directions without steps and have them construct from memory.

Explain why the steps of this construction work.

The center is equidistant from all points on the circle. Since the diameter goes through the center, the intersection of any two diameters is a point on both diameters and must be the center.

Exploratory Challenge (10 minutes)

Guide students in constructing a rectangle inscribed in a circle by constructing a right triangle (as in the Opening Exercise) and rotating the triangle about the center of the circle. Have students explore an alternate method, such as drawing a single chord, then constructing perpendicular chords three times. Review relevant vocabulary.

MP.1

- How can you use a right triangle (such as the one you constructed in the Opening Exercise above) to produce a rectangle whose four vertices lie on the circle?
 - *We can rotate the triangle 180° around the center of the circle (or around the midpoint of the diameter, which is the same thing).*

Exploratory Challenge

Construct a rectangle such that all four vertices of the rectangle lie on the circle below.

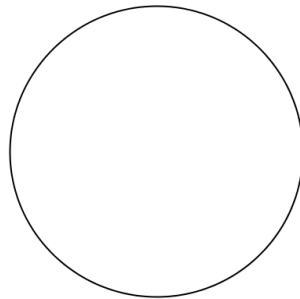

- Suppose we wanted to construct a rectangle with vertices on the circle, but we didn't want to use a triangle. Is there a way we could do this? Explain.
 - *We can construct a chord anywhere on the circle, then construct the perpendicular to one of its endpoints, and then repeat this twice more to construct our rectangle.*
- How can you be sure that the figure in the second construction is a rectangle?
 - *We know it is a rectangle because all four angles are right angles.*

Relevant Vocabulary

INSCRIBED POLYGON: A polygon is inscribed in a circle if all vertices of the polygon lie on the circle.

Exercises 1–5 (20 minutes)

For each exercise, ask students to explain why the construction is certain to produce the requested figure and to explain the symmetry across the diameter of each inscribed figure. Before students begin the exercises, ask the class, “What is symmetry?” Have a discussion, and let the students explain symmetry in their own words. They should describe symmetry as a reflection across an axis so that a figure lies on itself. Exercise 5 is a challenge exercise and can either be assigned to advanced learners or covered as a teacher-led example. In Exercise 5, students prove the converse of Thales’ theorem that they studied in Lesson 1.

Exercises 1–5

1. Construct a kite inscribed in the circle below, and explain the construction using symmetry.

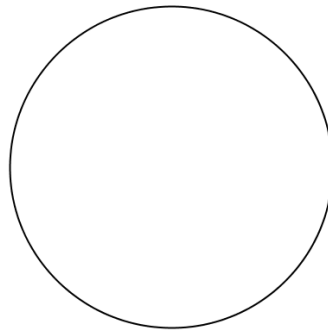

Construct $\triangle ABC$ as before, but this time reflect it across the diameter. It is a kite because, by reflection, there are two opposite pairs of congruent adjacent sides.

2. Given a circle and a rectangle, what must be true about the rectangle for it to be possible to inscribe a congruent copy of it in the circle?

The diagonals of the rectangle must be the length of the diameter of the circle.

3. The figure below shows a rectangle inscribed in a circle.

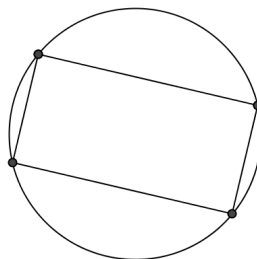

- a. List the properties of a rectangle.

Opposite sides parallel and congruent, four right angles, diagonals congruent, and bisect each other.

- b. List all the symmetries this diagram possesses.

Opposite sides are congruent, all four angles are congruent, diagonals are congruent, the figure may be reflected onto itself across the perpendicular bisector of the sides of the rectangle, the figure may be rotated onto itself with either a 180° or a 360° rotation either clockwise or counterclockwise.

- c. List the properties of a square.

Opposite sides parallel, all sides congruent, four right angles, diagonals congruent, bisect each other, and are perpendicular.

- d. List all the symmetries of the diagram of a square inscribed in a circle.

In addition to the symmetries listed above, all four sides are congruent, the figure may be reflected onto itself across the diagonals of the square, the figure may be rotated onto itself with either a 90° or a 270° rotation either clockwise or counterclockwise.

4. A rectangle is inscribed into a circle. The rectangle is cut along one of its diagonals and reflected across that diagonal to form a kite. Draw the kite and its diagonals. Find all the angles in this new diagram, given that the acute angle between the diagonals of the rectangle in the original diagram was 40° .

Draw diagrams such as the following:

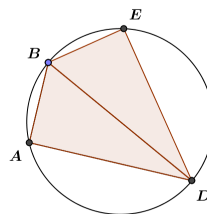
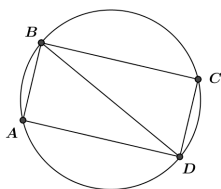

Given $m\angle ADB = 40^\circ$. Then $m\angle BDE = 40^\circ$; $m\angle BAD = m\angle BED = 90^\circ$; $m\angle ABD = m\angle EBD = 50^\circ$; $m\angle ABE = 100^\circ$; $m\angle ADE = 80^\circ$.

5. CHALLENGE: Show that the 3 vertices of a right triangle are equidistant from the midpoint of the hypotenuse by showing that the perpendicular bisectors of the legs pass through the midpoint of the hypotenuse. (This is called the Side-splitter theorem.)

- a. Draw the perpendicular bisectors of \overline{AB} and \overline{AC} .

- b. Label the point where they meet P . What is point P ?

The center of the circle.

- c. What can be said about the distance from P to each vertex of the triangle? What is the relationship between the circle and the triangle?

Point P is equidistant from the three vertices of the triangle A , B , and C , so the circle is circumscribed about $\triangle ABC$.

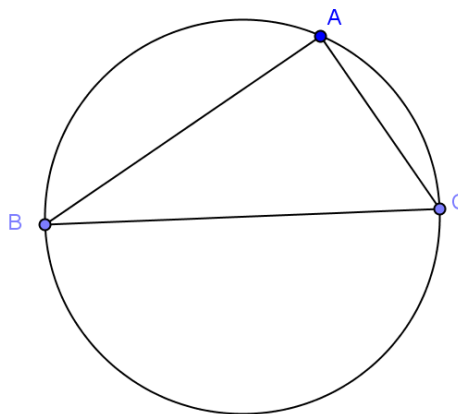

- d. Repeat this process, this time sliding B to another place on the circle and call it B' . What do you notice?

You get the same center.

- e. Using what you have learned about angles, chords, and their relationships, what does the position of point P depend on? Why?

The position of P depends only on $m\angle ABC$, not the position of B as long as B and B' are on the same side of \overline{AC} . $\angle ABC$ and $\angle AB'C$ have the same measure because they are inscribed in the same arc. The center of the circle in both cases is P .

Closing (1 minute)

Have students discuss the question with a neighbor or in groups of 3. Call the class back together and review the definition below.

- Explain how the symmetry of a rectangle across the diameter of a circle helps inscribe a rectangle in a circle.
 - *Since the rectangle is composed of two right triangles with the diameter as the hypotenuse, it is possible to construct one right triangle and then reflect it across the diameter.*

Lesson Summary

Relevant Vocabulary

INSCRIBED POLYGON: A polygon is *inscribed* in a circle if all vertices of the polygon lie on the circle.

Exit Ticket (5 minutes)

Name _____

Date _____

Lesson 3: Rectangles Inscribed in Circles

Exit Ticket

Rectangle $ABCD$ is inscribed in circle P . Boris says that diagonal AC could pass through the center, but it does not have to pass through the center. Is Boris correct? Explain your answer in words, or draw a picture to help you explain your thinking.

Exit Ticket Sample Solutions

Rectangle $ABCD$ is inscribed in circle P . Boris says that diagonal AC could pass through the center, but it does not have to pass through the center. Is Boris correct? Explain your answer in words, or draw a picture to help you explain your thinking.

Boris is not correct. Since each vertex of the rectangle is a right angle, the hypotenuse of the right triangle formed by each angle and the diagonal of the rectangle must be the diameter of the circle (by the work done in Lesson 1 of this module). The diameter of the circle passes through the center of the circle; therefore, the diagonal passes through the center.

Problem Set Sample Solutions

1. Using only a piece of 8.5×11 inch copy paper and a pencil, find the location of the center of the circle below.

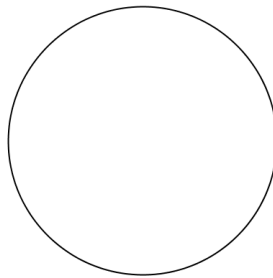

Lay the paper across the circle so that its corner lies on the circle. The points where the two edges of the paper cross the circle are the endpoints of a diameter. Mark those points, and draw the diameter using the edge of the paper as a straightedge. Repeat to get a second diameter. The intersection of the two diameters is the center of the circle.

2. Is it possible to inscribe a parallelogram that is not a rectangle in a circle?

No, although it is possible to construct an inscribed polygon with one pair of parallel sides (i.e., a trapezoid); a parallelogram requires that both pairs of opposite sides be parallel and both pairs of opposite angles be congruent. A parallelogram is symmetric by 180 degree rotation about its center and has NO other symmetry unless it is a rectangle. Two parallel lines and a circle create a figure that is symmetric by a reflection across the line through the center of the circle that is perpendicular to the two lines. If a trapezoid is formed with vertices where the parallel lines meet the circle, the trapezoid has reflectional symmetry. Therefore, it cannot be a parallelogram—UNLESS it is a rectangle.

3. In the figure, $BCDE$ is a rectangle inscribed in circle A . $DE = 8$; $BE = 12$. Find AE .

$$2\sqrt{13}$$

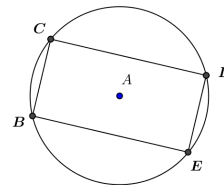

4. Given the figure, $BC = CD = 8$ and $AD = 13$.

Find the radius of the circle.

Mark the midpoint of \overline{BC} as point E . $BE = EC = 4$, so $ED = 12$.
 $\triangle EAD$ is a right triangle, so by the Pythagorean theorem,
 $EA = 5$. Using the Pythagorean theorem again gives
 $AC = \sqrt{41}$.

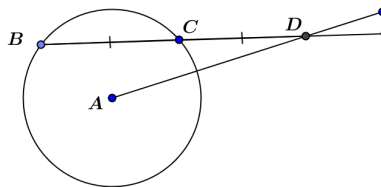

5. In the figure, \overline{DF} and \overline{BG} are parallel chords 14 cm apart. $DF = 12$ cm, $AB = 10$ cm, and $\overline{EH} \perp \overline{BG}$.

Find BG .

Draw $\triangle DEA$. $m\angle DEA = 90^\circ$, $DE = 6$, $DA = 10$. By Pythagorean theorem, $EA = 8$.

In $\triangle ABH$, $m\angle AHB = 90^\circ$, $AB = 10$, $AH = 6$, so $BH = 8$. This means $BG = 16$.

16 cm

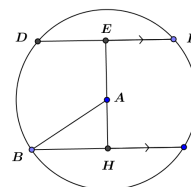

6. Use perpendicular bisectors of the sides of a triangle to construct a circle that circumscribes the triangle.

(Students did a construction similar to this in Geometry, Module 1, Lesson 4).

Draw any triangle.

Construct the perpendicular bisector of the sides.

The perpendicular bisectors meet at the circumcenter.

Using the center and the distance to one vertex as a radius, draw the circle.



Lesson 4: Experiments with Inscribed Angles

Student Outcomes

- Explore the relationship between *inscribed angles* and *central angles* and their *intercepted arcs*.

Lesson Notes

As with Lesson 1 in this module, students use simple materials to explore the relationship between different types of angles in circles. In Lesson 1, the exploration was limited to angles inscribed in diameters; in this lesson, we extend the concept to include all inscribed angles.

This lesson sets up concepts taught in Lessons 5–7. Problem 6 of the Problem Set is particularly important in setting up Lesson 5. Problem 7 of the Problem Set is an extension and will be revisited in Lesson 7.

Classwork

Have available for each student (or group) a straight edge, white paper, and trapezoidal paper cutouts, created by slicing standard colored 8.5×11 sheets of paper or cardstock from edge to edge using a paper cutter. There should be a variety of trapezoids with different acute angles available.

Opening Exercise (5 minutes)

Project the circle shown on the board. Have students identify the *central angle*, *inscribed angle*, *minor arc*, *major arc*, and *intercepted arc of an angle*. Have students write the definition of each in their own words, and then discuss the formal definitions. This vocabulary could be introduced with a series of prompts such as:

- \widehat{BE} is a minor arc. \widehat{EDB} is a major arc. Explain the difference between a major arc and minor arc.
- $\angle BDC$ is an inscribed angle. $\angle BAC$ is a central angle. Explain the difference between an inscribed angle and a central angle.
- $\angle CDB$ and $\angle CAB$ both intercept arc \widehat{BC} . Explain what you think it means for an angle to intercept an arc.

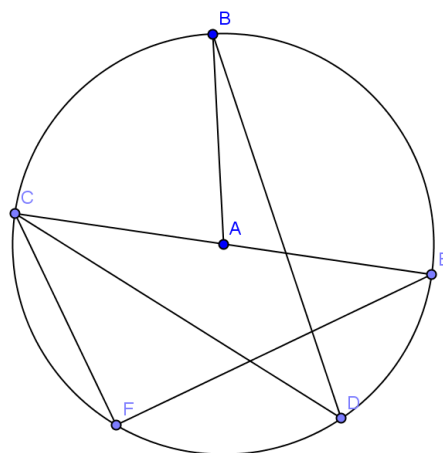

Opening Exercise

ARC: An arc is a portion of the circumference of a circle.

MINOR AND MAJOR ARC: Let C be a circle with center O , and let A and B be different points that lie on C but are not the endpoints of the same diameter. The minor arc is the set containing A , B , and all points of C that are in the interior of $\angle AOB$. The major arc is the set containing A , B , and all points of C that lie in the exterior of $\angle AOB$. Examples: Minor Arc \widehat{BE} , \widehat{ED} . Major Arc \widehat{EDB} , \widehat{DCE} . Answers will vary.

INSCRIBED ANGLE: An inscribed angle is an angle whose vertex is on a circle and each side of the angle intersects the circle in another point. Examples: $\angle BDC$, $\angle ECD$. Answers will vary.

CENTRAL ANGLE: A central angle of a circle is an angle whose vertex is the center of a circle. Examples: $\angle CAB$, $\angle BAE$. Answers will vary.

INTERCEPTED ARC OF AN ANGLE. An angle intercepts an arc if the endpoints of the arc lie on the angle, all other points of the arc are in the interior of the angle, and each side of the angle contains an endpoint of the arc. Examples: \widehat{ED} , \widehat{CF} . Answers will vary.

Exploratory Challenge 1 (10 minutes)

Exploratory Challenge 1

Your teacher will provide you with a straight edge, a sheet of colored paper in the shape of a trapezoid, and a sheet of plain white paper.

- Draw 2 points no more than 3 inches apart in the middle of the plain white paper, and label them A and B .
- Use the acute angle of your colored trapezoid to plot a point on the white sheet by placing the colored cutout so that the points A and B are on the edges of the acute angle and then plotting the position of the vertex of the angle. Label that vertex C .
- Repeat several times. Name the points D , E ,

Scaffolding:

- If students are struggling with acute and obtuse angles of a trapezoid being supplementary, have them confirm by folding or tearing the trapezoid into segments containing the angles and putting them together as they did in Grade 5, Module 6.
- Display the definition of supplementary angles.

The students' task is as appears below:

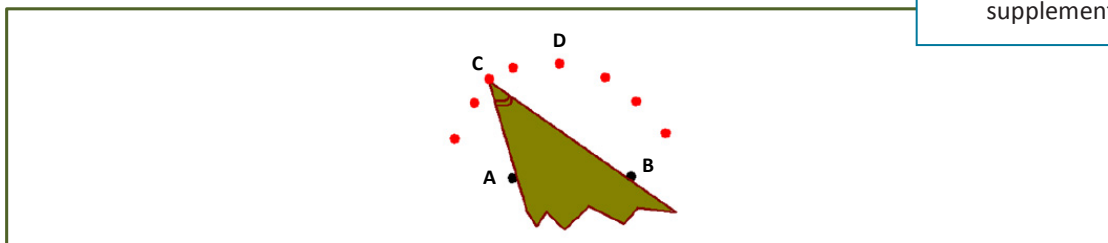

MP.3
&
MP.7

- As students receive their materials, ask them to label the acute angle of the trapezoid. What is the relationship between the acute angle and the obtuse angle?
 - *They are supplementary.*
- As students complete the point-plotting, ask, “What shape do the plotted points form?”
 - *The points seem to be the major arc of a circle.*
- How can you find the minor arc of the circle? Explain how you know.
 - *We can find the minor arc of the circle by pushing the supplementary angle of the trapezoid through the two original points from above. If the acute angle creates a major arc, the supplementary angle would produce a smaller (minor) arc.*
- How does this relate to the work we did on Thales’ theorem in Lesson 1?
 - *In Lesson 1, we showed that a triangle created by connecting the endpoints of a diameter with any other point on a circle is a right triangle. We used a right angle (a corner of a plain piece of paper) to create our original semicircle. Here, we are using the acute and obtuse angles of a trapezoid to create major and minor arcs of a circle.*

Exploratory Challenge 2 (10 minutes)

Have students further explore the angles formed by connecting points A and B in their drawing with any one of the points they marked at the vertex $(C, D, E \dots)$ as it was moved through points A and B .

- When you trace over the angles formed by points A and B and the vertex point $(C, D, E \dots)$ you marked, what do you notice about the measures of the angles you drew?
 - *All angles drawn with a vertex on the major arc have the same measure – the measure of the acute angle of the trapezoid.*
- What happens when you trace over the angles formed by points A and B and the vertex of the obtuse angle?
 - *All angles drawn with a vertex on the minor arc have the same measure – the measure of the obtuse angle of the trapezoid.*

Exploratory Challenge 2

- a. Draw several of the angles formed by connecting points A and B on your paper with any of the additional points you marked as the acute angle was “pushed” through the points (C, D, E, \dots) . What do you notice about the measures of these angles?

All angles have the same measure – the measure of the acute angle on the trapezoid.

- b. Draw several of the angles formed by connecting points A and B on your paper with any of the additional points you marked as the obtuse angle was “pushed” through the points from above. What do you notice about the measures of these angles?

All angles have the same measure – the measure of the obtuse angle on the trapezoid.

MP.8

Exploratory Challenge 3 (10 minutes)

Continue the exploration, providing each student with several copies of the circle at the end of the lesson, a straightedge, and scissors. They will select a point on the circle and create an inscribed angle. Each student will cut out his or her angle and compare it to the angle of several neighbors. All students started with the same arc thus, all inscribed angles will have the same measure. This can also be confirmed using protractors to measure the angles instead of cutting the angles out or modeled by the teacher.

Exploratory Challenge 3

- a. Draw a point on the circle, and label it D . Create angle $\angle BDC$.
- b. $\angle BDC$ is called an inscribed angle. Can you explain why?

The vertex is on the circle, and the sides of the angle pass through points that are also on the circle.

- c. Arc \widehat{BC} is called the intercepted arc. Can you explain why?

It is the arc cut in the circle by the inscribed angle.

- d. Carefully cut out the inscribed angle, and compare it to the angles of several of your neighbors.
- e. What appears to be true about each of the angles you drew?

All appear to have the same measure.

- f. Draw another point on a second circle, and label it point E . Create angle $\angle BEC$, and cut it out. Compare $\angle BDC$ and $\angle BEC$. What appears to be true about the two angles?

All appear to have the same measure.

- g. What conclusion may be drawn from this? Will all angles inscribed in the circle from these two points have the same measure?

All angles inscribed in the circle from these two points will have the same measure.

- h. Explain to your neighbor what you have just discovered.

Exploratory Challenge 4 (3 minutes)

Extend the exploration, using the circle given, select two points on the circle (B and C), and use those two points as endpoints of an intercepted arc for a central angle.

Exploratory Challenge 4

- a. In the circle below, draw the angle formed by connecting points B and C to the center of the circle.

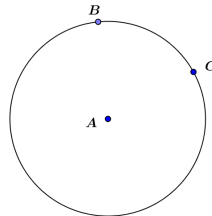

- b. Is $\angle BAC$ an inscribed angle? Explain.

No. The vertex is not on the circle; the vertex is the center of the circle.

- c. Is it appropriate to call this *the* central angle? Why or why not?

The acute angle ($\angle BAC$) is formed by connecting points B and C to the center point (A), so it would be appropriate to call this a central angle.

- d. What is the intercepted arc?

The intercepted arc is \widehat{BC} .

- e. Is the measure of $\angle BAC$ the same as the measure of one of the inscribed angles in Example 2?

No, the measure of $\angle BAC$ is greater.

- f. Can you make a prediction about the relationship between the inscribed angle and the central angle?

The inscribed angle is about half the central angle. The central angle is double the inscribed angle.

Closing (2 minutes)

Have students explain to a partner the answer to the prompt below, and then call the class together to review the Lesson Summary.

- What is the difference between an inscribed angle and a central angle?

Lesson Summary

All inscribed angles from the same intercepted arc have the same measure.

Relevant Vocabulary

- **ARC:** An *arc* is a portion of the circumference of a circle.
- **MINOR AND MAJOR ARC:** Let C be a circle with center O , and let A and B be different points that lie on C but are not the endpoints of the same diameter. The *minor arc* is the set containing A , B , and all points of C that are in the interior of $\angle AOB$. The *major arc* is the set containing A , B , and all points of C that lie in the exterior of $\angle AOB$.
- **INSCRIBED ANGLE:** An *inscribed angle* is an angle whose vertex is on a circle, and each side of the angle intersects the circle in another point.
- **CENTRAL ANGLE:** A *central angle* of a circle is an angle whose vertex is the center of a circle.
- **INTERCEPTED ARC OF AN ANGLE:** An angle *intercepts* an arc if the endpoints of the arc lie on the angle, all other points of the arc are in the interior of the angle, and each side of the angle contains an endpoint of the arc.

Exit Ticket (5 minutes)

Name _____

Date _____

Lesson 4: Experiments with Inscribed Angles

Exit Ticket

Joey marks two points on a piece of paper, as we did in the Exploratory Challenge, and labels them A and B . Using the trapezoid shown below, he pushes the acute angle through points A and B from below several times so that the sides of the angle touch points A and B , marking the location of the vertex each time. Joey claims that the shape he forms by doing this is the minor arc of a circle and that he can form the major arc by pushing the obtuse angle through points A and B from above. “The obtuse angle has the greater measure, so it will form the greater arc,” states Joey.

Ebony disagrees, saying that Joey has it backwards. “The acute angle will trace the major arc,” claims Ebony.

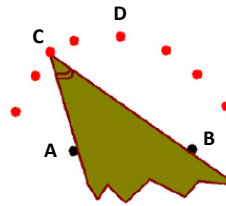
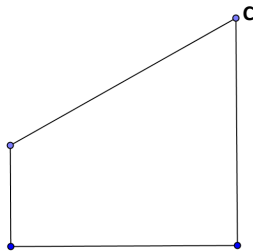

1. Who is correct, Joey or Ebony? Why?
2. How are the acute and obtuse angles of the trapezoid related?
3. If Joey pushes one of the right angles through the two points, what type of figure is created? How does this relate to the major and minor arcs created above?

Exit Ticket Sample Solutions

Joey marks two points on a piece of paper, as we did in the Exploratory Challenge, and labels them A and B . Using the trapezoid shown below, he pushes the acute angle through points A and B from below several times so that the sides of the angle touch points A and B , marking the location of the vertex each time. Joey claims that the shape he forms by doing this is the minor arc of a circle and that he can form the major arc by pushing the obtuse angle through points A and B from above. "The obtuse angle has the greater measure, so it will form the greater arc," states Joey.

Ebony disagrees, saying that Joey has it backwards. "The acute angle will trace the major arc," claims Ebony.

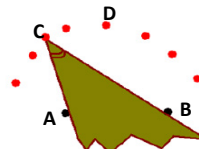
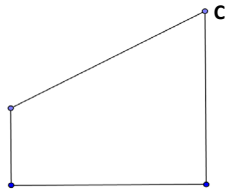

1. Who is correct, Joey or Ebony? Why?

Ebony is correct. The acute angle vertex traces out the major arc of the circle.

2. How are the acute and obtuse angles of the trapezoid related?

They are supplementary.

3. If Joey pushes one of the right angles through the two points, what type of figure is created? How does this relate to the major and minor arcs created above?

A semicircle is created. Both arcs will be the same measure (180°).

Problem Set Sample Solutions

1. Using a protractor, measure both the inscribed angle and the central angle shown on the circle below.

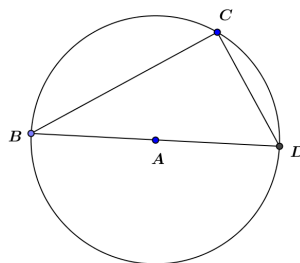

$m\angle BCD =$ _____

$m\angle BAD =$ _____

90°; 180°

2. Using a protractor, measure both the inscribed angle and the central angle shown on the circle below.

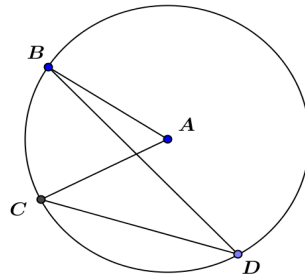

$m\angle BDC =$ _____

$m\angle BAC =$ _____

30°; 60°

3. Using a protractor, measure both the inscribed angle and the central angle shown on the circle below.

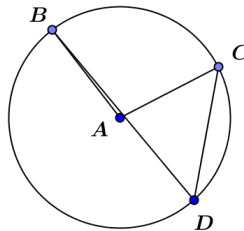

$m\angle BDC =$ _____

$m\angle BAC =$ _____

50°; 100°

4. What relationship between the measure of the inscribed angle and the measure of the central angle that intercept the same arc is illustrated by these examples?

The measure of the inscribed angle appears to be half the measure of the central angle that intercepts the same arc.

5. Is your conjecture at least true for inscribed angles that measure 90°?

Yes, according to Thales' theorem, if A, B, and C are points on a circle where \overline{AC} is a diameter of the circle, then $\angle ABC$ is a right angle. Since a diameter represents an 180° angle, our conjecture is always true for angles that measure 90°.

6. Prove that $y = 2x$ in the diagram below.

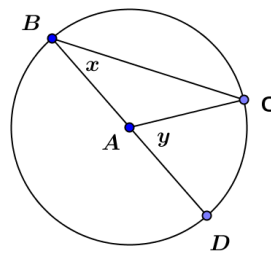

$\triangle ABC$ is an isosceles triangle since all radii of a circle are congruent. Therefore, $m\angle B = m\angle C = x$. In addition, $y = m\angle B + m\angle C$ since the measure of an exterior angle of a triangle is equal to the sum of the measures of the opposite interior angles. By substitution, $y = x + x$, or $y = 2x$.

7. Red (R) and blue (B) lighthouses are located on the coast of the ocean. Ships traveling are in safe waters as long as the angle from the ship (S) to the two lighthouses ($\angle RSB$) is always less than or equal to some angle θ called the “danger angle.” What happens to θ as the ship gets closer to shore and moves away from shore? Why do you think a larger angle is dangerous?

The closer the boat is to the shore, the larger θ will be, and as the boat moves away from shore, θ gets smaller. A smaller θ means the ship is in deeper water, which is safer for ships.

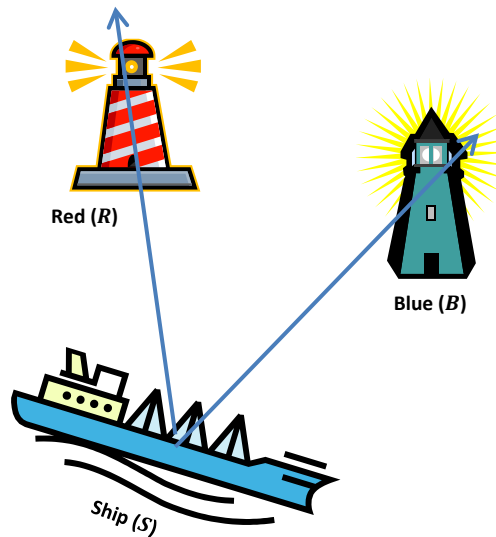

Example 2

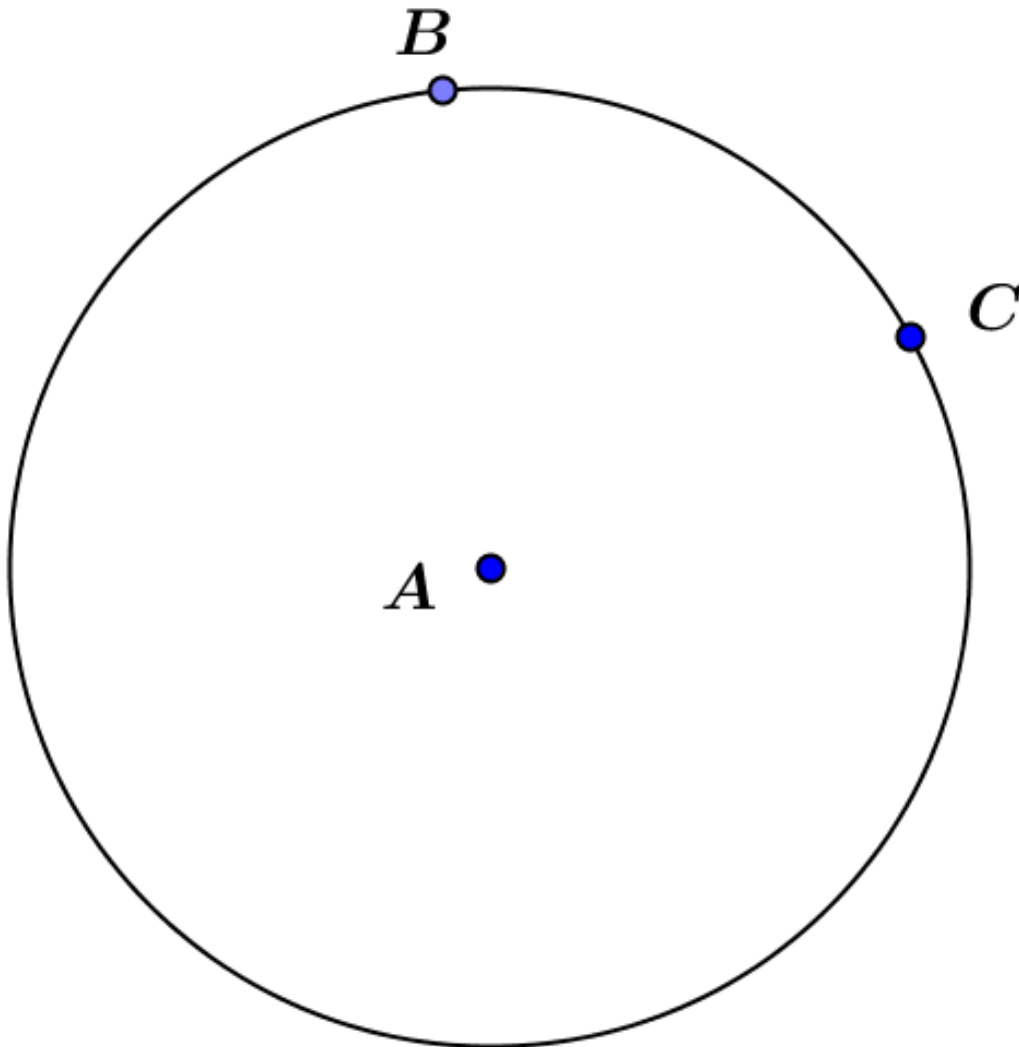



Lesson 5: Inscribed Angle Theorem and its Applications

Student Outcomes

- Prove the *inscribed angle theorem*: The measure of a central angle is twice the measure of any inscribed angle that intercepts the same arc as the central angle.
- Recognize and use different cases of the inscribed angle theorem embedded in diagrams. This includes recognizing and using the result that inscribed angles that intersect the same arc are equal in measure.

Lesson Notes

Lesson 5 introduces but does not finish the inscribed angle theorem. The statement of the inscribed angle theorem in this lesson should be only in terms of the measures of central angles and inscribed angles, not the angle measures of *intercepted arcs*. The measure of the inscribed angle is deduced and the central angle is given, not the other way around in Lesson 5. This lesson only includes inscribed angles and central angles that are acute or right. Obtuse angles will not be studied until Lesson 7.

The Opening Exercise and Examples 1 and 2 are the complete proof of the inscribed angle theorem (central angle version).

Classwork

Opening

Lead students through a discussion of the Opening Exercise (an adaptation of Lesson 4 Problem Set 6), and review terminology, *especially intercepted arc*. Knowing the definition of intercepted arc is critical for understanding this and future lessons. The goal is for students to understand why the Opening Exercise supports, but is not a complete proof of the inscribed angle theorem, and then to make diagrams of the remaining cases, which are addressed in Examples 1–2 and Exercise 1.

Scaffolding:

- Include a diagram in which point B and angle ABC are already drawn.

Opening Exercise (7 minutes)

Opening Exercise

- A and C are points on a circle with center O .
 - Draw a point B on the circle so that \overline{AB} is a diameter. Then draw the angle $\angle ABC$.
 - What angle in your diagram is an inscribed angle?
 $\angle ABC$

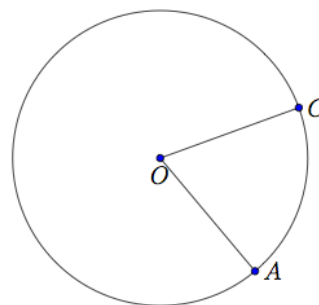

c. What angle in your diagram is a central angle?
 $\angle AOC$

d. What is the intercepted arc of angle $\angle ABC$?
 Minor arc \widehat{AC}

e. What is the intercepted arc of $\angle AOC$?
 Minor arc \widehat{AC}

2. The measure of the inscribed angle is x and the measure of the central angle is y . Find $m\angle CAB$ in terms of x ?
We are given $m\angle D = x$, and we know that $AB = AC = AD$, so $\triangle CAD$ is an isosceles triangle, meaning $m\angle ACD$ is also x . The sum of the angles of a triangle is 180, so $m\angle CAD = 180 - 2x$. $\angle CAD$ and $\angle CAB$ are supplementary meaning that $m\angle CAB = 180 - (180 - 2x) = 2x$; therefore, $y = 2x$.

Relevant Vocabulary

INSCRIBED ANGLE THEOREM (as it will be stated in Lesson 7): The measure of an inscribed angle is half the angle measure of its intercepted arc.

INSCRIBED ANGLE: An inscribed angle is an angle whose vertex is on a circle, and each side of the angle intersects the circle in another point.

ARC INTERCEPTED BY AN ANGLE: An angle intercepts an arc if the endpoints of the arc lie on the angle, all other points of the arc are in the interior of the angle, and each side of the angle contains an endpoint of the arc. An angle inscribed in a circle intercepts exactly one arc; in particular, the arc intercepted by a right angle is the semicircle in the interior of the angle.

Exploratory Challenge (10 minutes)

Review the definition of intercepted arc, inscribed angle, and central angle and then state the inscribed angle theorem. Then highlight the fact that we have proved one case but not all cases of the inscribed angle theorem (the case in which a side of the angle passes through the center of the circle). Sketch drawings of various cases to set up; for instance, Example 1 could be the inside case and Example 2 could be the outside case. You may want to sketch them in a place where you can refer to them throughout the class.

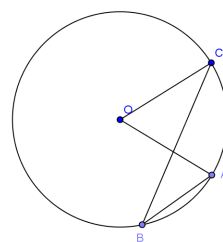
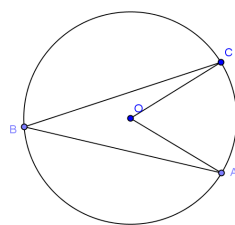

Scaffolding:

- Post drawings of each case as they are studied in the class as well as the definitions of inscribed angles, central angles, and intercepted arcs.

MP.7

- What do you notice that is the same or different about each of these pictures?
 - *Answers will vary.*
- What arc is intercepted by $\angle ABC$?
 - *The minor arc \widehat{AC}*
- How do you know this arc is intercepted by $\angle ABC$?
 - *The endpoints of the arc (A and C) lie on the angle.*
 - *All other points of the arc are inside the angle.*
 - *Each side of the angle contains one endpoint of the arc.*
- **THEOREM:** The measure of a central angle is twice the measure of any inscribed angle that intercepts the same arc as the central angle.
- Today we're going to talk about the inscribed angle theorem. It says the following: The measure of a central angle is twice the measure of any inscribed angle that intercepts the same arc as the central angle. Does the Opening Exercise satisfy the conditions of the inscribed angle theorem?
 - *Yes. $\angle ABC$ is an inscribed angle and $\angle AOC$ is a central angle both of which intercept the same arc.*
- What did we show about the inscribed angle and central angle with the same intersected arc in the Opening Exercise?
 - *That the measure of $\angle AOC$ is twice the measure of $\angle ABC$.*
 - *This is because $\triangle OBC$ is an isosceles triangle whose legs are radii. The base angles satisfy $m\angle B = m\angle C = x$. So, $y = 2x$ because the exterior angle of a triangle is equal to the sum of the measures of the opposite interior angles.*
- Does the conclusion of the Opening Exercise match the conclusion of the inscribed angle theorem?
 - *Yes.*
- Does this mean we have proven the inscribed angle theorem?
 - *No. The conditions of the inscribed angle theorem say that $\angle ABC$ could be any inscribed angle. The vertex of the angle could be elsewhere on the circle.*
- How else could the diagram look?
 - *Students may say that diagram could have the center of the circle be inside, outside, or on the inscribed angle. The Opening Exercise only shows the case when the center is on the inscribed angle. (Discuss with students that the precise way to say "inside the angle" is to say "in the interior of the angle.")*

2.

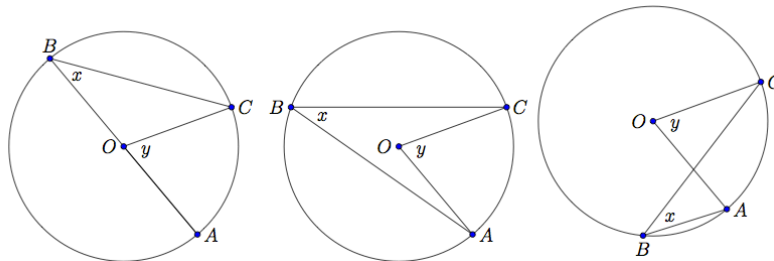

- *We still need to show the cases when the center is inside and outside the inscribed angle.*

- There is one more case, when B is on the minor arc between A and C instead of the major arc.
 - If students ask where the x and y are in this diagram, say we'll find out in Lesson 7.

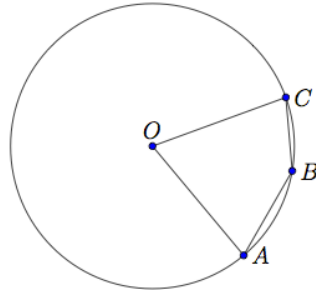

Scaffolding:

- Before doing Examples 1 and 2, or instead of going through the examples, teachers could do an exploratory activity using the triangles shown in Exercise 3 parts (a), (b), and (c). Have students measure the central and inscribed angles, intercepting the same arc with a protractor, then log the measurements in a table, and look for a pattern.

Examples 1–2 (10 minutes)

These examples prove the second and third case scenarios – the case when the center of the circle is *inside* or *outside* the inscribed angle and the inscribed angle is acute. Both use similar computations based on the Opening Exercise. Example 1 is easier to see than Example 2. For Example 2, you may want to let students figure out the diagram on their own, but then go through the proof as a class.

Go over proofs of Examples 1–2 with the case when angle $\angle ABC$ is acute. If a student draws B so that angle $\angle ABC$ is obtuse, save the diagram for later when doing Lesson 7.

Note that the diagrams for the Opening Exercise as well as Examples 1–2 have been labeled so that in each diagram, O is the center, $\angle ABC$ is an inscribed angle, and $\angle AOC$ is a central angle. This consistency highlights parallels between the computations in the three cases.

Example 1

A and C are points on a circle with center O .

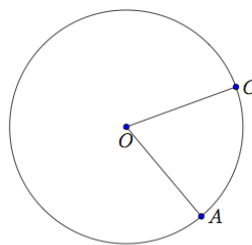

- a. What is the intercepted arc of $\angle COA$? Color it red.

Minor arc \widehat{AC}

- b. Draw triangle AOC . What type of triangle is it? Why?

An isosceles triangle because $OC = OA$ (they are radii of the same circle).

- c. What can you conclude about $m\angle OCA$ and $m\angle OAC$? Why?

They are equal because base angles of an isosceles triangle are equal in measure.

- d. Draw a point B on the circle so that O is in the interior of the inscribed angle $\angle ABC$.

The diagram should resemble the inside case of the discussion diagrams.

- e. What is the intercepted arc of angle $\angle ABC$? Color it green.

Minor arc \widehat{AC}

- f. What do you notice about arc \widehat{AC} ?

It is the same arc that was intercepted by the central angle.

- g. Let the measure of $\angle ABC$ be x and the measure of $\angle AOC$ be y . Can you prove that $y = 2x$? (Hint: Draw the diameter that contains point B .)

Let \overline{BD} be a diameter. Let $x_1, y_1, x_2,$ and y_2 be the measures of $\angle CBD, \angle COD, \angle ABD,$ and $\angle AOD,$ respectively. We can express x and y in terms of these measures: $x = x_1 + x_2,$ and $y = y_1 + y_2.$ By the opening exercise, $y_1 = 2x_1$ and $y_2 = 2x_2.$ Thus $y = 2x.$

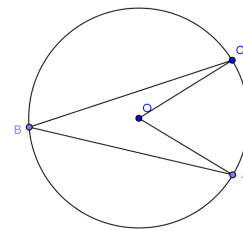

- h. Does your conclusion support the inscribed angle theorem?

Yes, even when the center of the circle is in the interior of the inscribed angle, the measure of the inscribed angle is equal to half the measure of the central angle that intercepts the same arc.

- i. If we combine the Opening Exercise and this proof, have we finished proving the inscribed angle theorem?

No. We still have to prove the case where the center is outside the inscribed angle.

Example 2

A and C are points on a circle with center O .

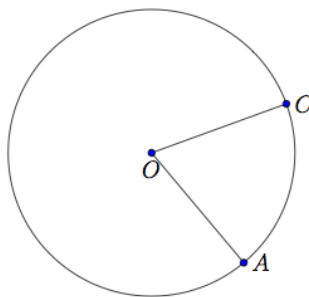

- a. Draw a point B on the circle so that O is in the exterior of the inscribed angle $\angle ABC$.

The diagram should resemble the outside case of the discussion diagrams.

b. What is the intercepted arc of angle $\angle ABC$? Color it yellow.
Minor arc \widehat{AC}

c. Let the measure of $\angle ABC$ be x , and the measure of $\angle AOC$ be y . Can you prove that $y = 2x$? (Hint: Draw the diameter that contains point B .)
*Let \overline{BD} be a diameter. Let $x_1, y_1, x_2,$ and y_2 be the measures of $\angle CBD, \angle COD, \angle ABD,$ and $\angle AOD,$ respectively. We can express x and y in terms of these measures:
 $x = x_2 - x_1$ and $y = y_2 - y_1$ By the Opening Exercise, $y_1 = 2x_1$ and $y_2 = 2x_2$. Thus, $y = 2x$.*

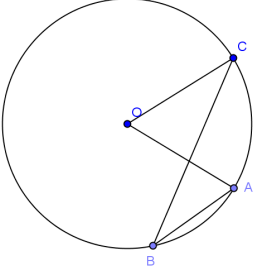

d. Does your conclusion support the inscribed angle theorem?
Yes, even when the center of the circle is in the exterior of the inscribed angle, the measure of the inscribed angle is equal to half the measure of the central angle that intercepts the same arc.

e. Have we finished proving the inscribed angle theorem?
We have shown all cases of the inscribed angle theorem (central angle version). We do have one more case to study in Lesson 7, but it is ok not to mention it here. The last case is when the location of B is on the minor arc between A and C .

Ask students to summarize the results of these theorems to each other before moving on.

Exercises 1–5 (10 minutes)

Exercises are listed in order of complexity. Students do not have to do all problems. Problems can be specifically assigned to students based on ability.

Exercises 1–5

1. Find the measure of the angle with measure x .

a. $m\angle D = 25^\circ$ b. $m\angle D = 15^\circ$ c. $m\angle BAC = 90^\circ$

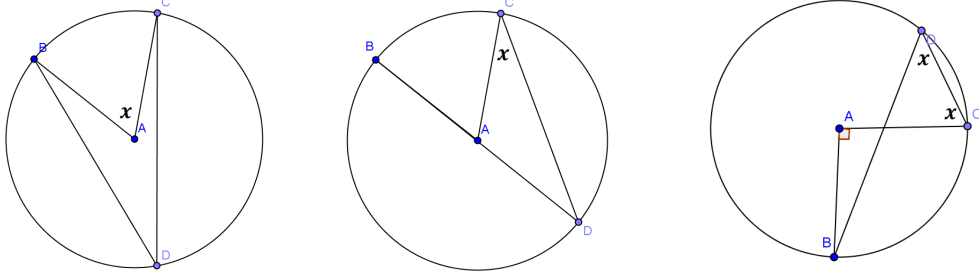

50° 150° 45°

d. $m\angle B = 32^\circ$

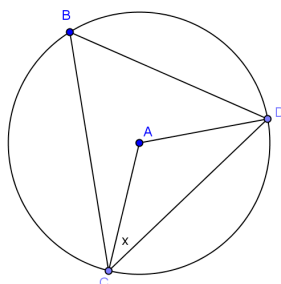

58°

e.

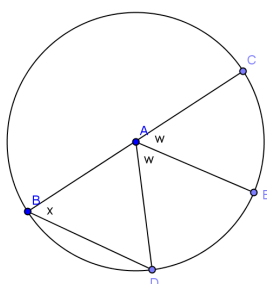

$x = w = 60^\circ$

f. $m\angle D = 19^\circ$

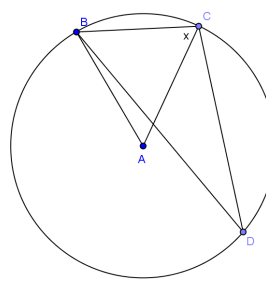

71°

2. Toby says $\triangle BEA$ is a right triangle because $m\angle BEA = 90^\circ$. Is he correct? Justify your answer.

Toby is not correct. The $m\angle BEA = 95^\circ$. $\angle BCD$ is inscribed in the same arc as the central angle, so it has a measure of 35° . This means that $m\angle DEC = 95^\circ$ because the sum of the angles of a triangle is 180° . $m\angle BEA = m\angle DEC$ since they are vertical angles, so the triangle is not right.

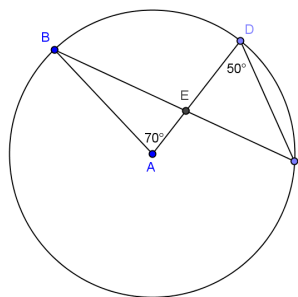

3. Let's look at relationships between inscribed angles.

a. Examine the inscribed polygon below. Express x in terms of y and y in terms of x . Are the opposite angles in any quadrilateral inscribed in a circle supplementary? Explain.

$x = 180^\circ - y$; $y = 180^\circ - x$. *The angles are supplementary.*

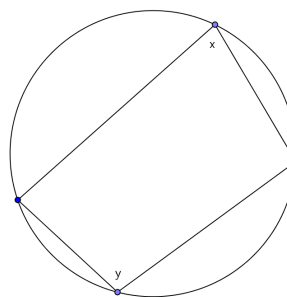

b. Examine the diagram below. How many angles have the same measure, and what are their measures in terms of x ?

Let C and D be the points on the circle that the original angles contain. All the angles intercepting the minor arc between C and D have measure x , and the angles intercepting the major arc between C and D measure $180^\circ - x$.

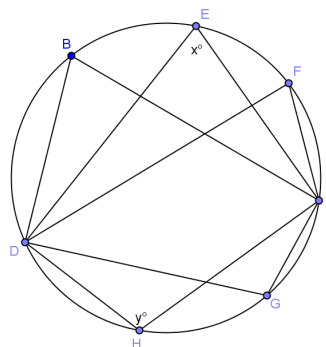

4. Find the measures of the labeled angles.

a.

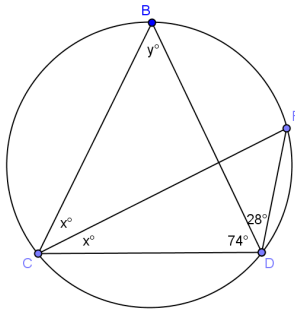

$x = 28, y = 50$

b.

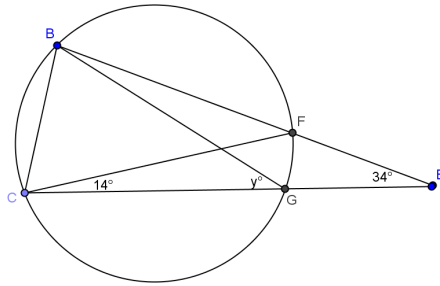

$y = 48$

c.

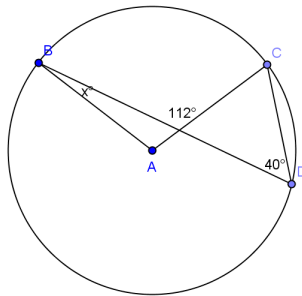

$x = 32$

d.

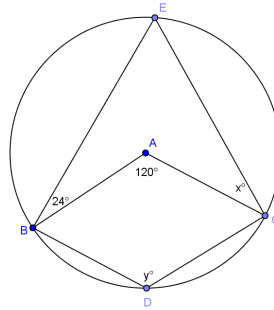

$x = 36, y = 120$

e.

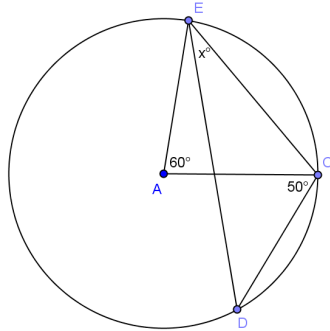

$x = 40$

f.

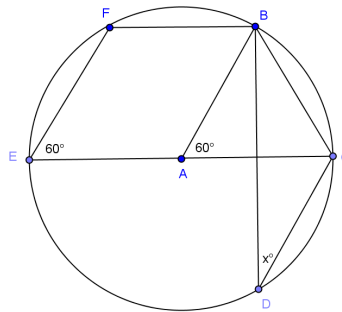

$x = 30$

Closing (3 minutes)

- With a partner, do a 30-second Quick Write of everything that we learned today about the inscribed angle theorem.
 - *Today we began by revisiting the Problem Set from yesterday as the key to the proof of a new theorem, the inscribed angle theorem. The practice we had with different cases of the proof allowed us to recognize the many ways that the inscribed angle theorem can show up in unknown angle problems. We then solved some unknown angle problems using the inscribed angle theorem combined with other facts we knew before.*
 - *Have students add the theorems in the Lesson Summary to their graphic organizer on circles started in Lesson 2 with corresponding diagrams.*

Lesson Summary

THEOREMS:

- **THE INSCRIBED ANGLE THEOREM:** The measure of a central angle is twice the measure of any inscribed angle that intercepts the same arc as the central angle.
- **CONSEQUENCE OF INSCRIBED ANGLE THEOREM:** Inscribed angles that intercept the same arc are equal in measure.

Relevant Vocabulary

- **INSCRIBED ANGLE:** An *inscribed angle* is an angle whose vertex is on a circle, and each side of the angle intersects the circle in another point.
- **INTERCEPTED ARC:** An angle *intercepts* an arc if the endpoints of the arc lie on the angle, all other points of the arc are in the interior of the angle, and each side of the angle contains an endpoint of the arc. An angle inscribed in a circle intercepts exactly one arc; in particular, the arc intercepted by a right angle is the semicircle in the interior of the angle.

Exit Ticket (5 minutes)

Name _____

Date _____

Lesson 5: Inscribed Angle Theorem and its Application

Exit Ticket

The center of the circle below is O . If angle B has a measure of 15 degrees, find the values of x and y . Explain how you know.

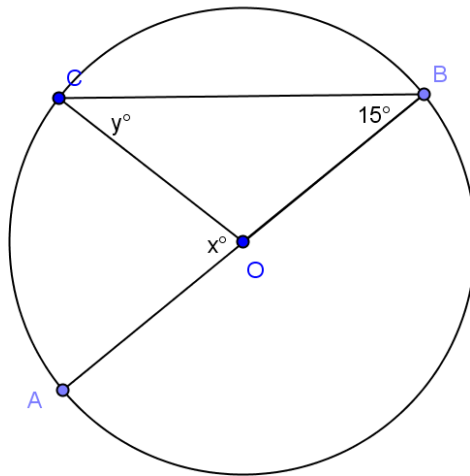

Exit Ticket Sample Solutions

The center of the circle below is O . If angle B has a measure of 15 degrees, find the values of x and y . Explain how you know.

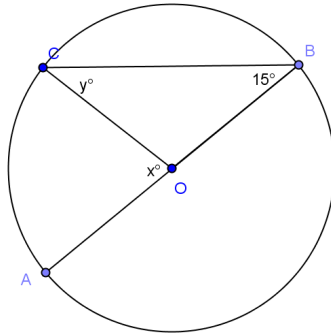

$y = 15$. Triangle COB is isosceles, so base angles $\angle OCB$ and $\angle OBC$ are congruent. $m\angle OBC = 15 = m\angle OCB$.
 $x = 30$. $\angle COA$ is a central angle inscribed in the same arc as inscribed angle $\angle CBA$. So $m\angle COA = 2m\angle CBA$.

Problem Set Sample Solutions

Problems 1–2 are intended to strengthen students’ understanding of the proof of the inscribed angle theorem. The other problems are applications of the inscribed angle theorem. Problems 3–5 are the most straightforward of these, followed by Problem 6, then Problems 7–9, which combine use of the inscribed angle theorem with facts about triangles, angles, and polygons. Finally, Problem 10 combines all the above with the use of auxiliary lines in its proof.

Find the value of x in each exercise.

1.

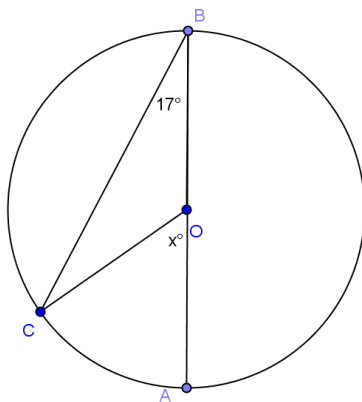

$x = 34$

2.

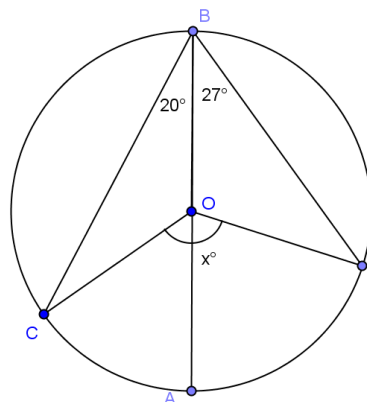

$x = 94$

3.

$x = 30$

4.

$x = 70$

5.

$x = 60$

6.

$x = 60$

7.

$x = 20$

8.

$x = 46$

9.

- a. The two circles shown intersect at E and F . The center of the larger circle, D , lies on the circumference of the smaller circle. If a chord of the larger circle, \overline{FG} , cuts the smaller circle at H , find x and y .

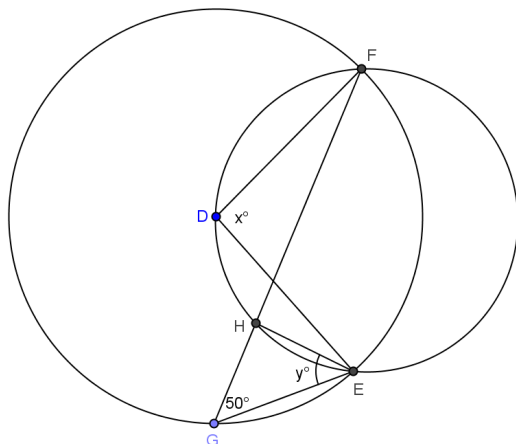

$x = 100; y = 50$

- b. How does this problem confirm the inscribed angle theorem?

$\angle FDE$ is a central angle of the larger circle and is double $\angle FGE$, the inscribed angle of the larger circle. $\angle FDE$ is inscribed in the smaller circle and equal in measure to $\angle FHE$, also inscribed in the smaller circle.

10. In the figure below, \overline{ED} and \overline{BC} intersect at point E .

Prove: $m\angle DAB + m\angle EAC = 2(m\angle BFD)$

PROOF: Join \overline{BE} .

$$m\angle BED = \frac{1}{2}(m\angle \underline{\hspace{2cm}})$$

$$m\angle EBC = \frac{1}{2}(m\angle \underline{\hspace{2cm}})$$

In $\triangle EBF$,

$$m\angle BEF + m\angle EBF = m\angle \underline{\hspace{2cm}}$$

$$\frac{1}{2}(m\angle \underline{\hspace{2cm}}) + \frac{1}{2}(m\angle \underline{\hspace{2cm}}) = m\angle \underline{\hspace{2cm}}$$

$$\therefore m\angle DAB + m\angle EAC = 2(m\angle BFD)$$

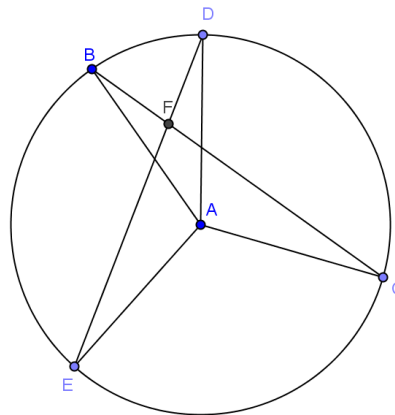

BAD; EAC; BFD; DAB, EAC, BFD



Lesson 6: Unknown Angle Problems with Inscribed Angles in Circles

Student Outcomes

- Use the *inscribed angle theorem* to find the measures of unknown angles.
- Prove relationships between *inscribed angles* and *central angles*.

Lesson Notes

Lesson 6 continues the work of Lesson 5 on the inscribed angle theorem. Many of the problems in Lesson 6 have chords that meet outside of the circle, and students are looking at relationships between triangles formed within circles and finding angles using their knowledge of the inscribed angle theorem and Thales’ theorem. When working on unknown angle problems, present them as puzzles to be solved. Students are to use what is known to find missing pieces of the puzzle until they find the piece asked for in the problem. Calling these puzzles instead of problems will encourage students to persevere in their work and see it more as a fun activity.

Classwork

Opening Exercise (10 minutes)

Allow students to work in pairs or groups of three and work through the proof below, writing their work on large paper. Some groups may need more guidance, and others may need you to model this problem. Call students back together as a class, and have groups present their work. Use this as an informal assessment of student understanding. Compare work and clear up misconceptions. Also, talk about different strategies groups used.

Opening Exercise

In a circle, a chord \overline{DE} and a diameter \overline{AB} are extended outside of the circle to meet at point C . If $m\angle DAE = 46^\circ$, and $m\angle DCA = 32^\circ$, find $m\angle DEA$.

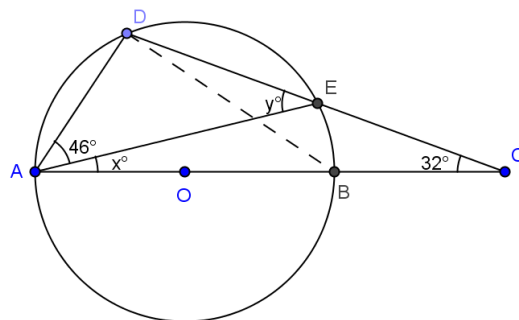

Scaffolding:

- Create a Geometry Axiom/Theorem wall, similar to a Word Wall, so students will have easy reference. Allow students to create colorful designs and display their work. For example, a student draws a picture of an inscribed angle and a central angle intercepting the same arc and color codes it with the angle relationship between the two noted. Students could be assigned axioms, theorems, or terms to illustrate so that all students would have work displayed.
- For advanced learners, present the problem from the Opening Exercise and ask them to construct the proof without the guided steps.

MP.3

Let $m\angle DEA = y$, $m\angle EAE = x$

In $\triangle ABD$, $m\angle DBA = y$ Reason *angles inscribed in same arc are congruent*

$m\angle ADB = 90^\circ$ Reason *angle inscribed in semicircle*

$\therefore 46 + x + y + 90 = 180$ Reason *sum of angles of triangle = 180°*

$x + y = 44$

In $\triangle ACE$, $y = x + 32$ Reason *Ext. angle of a triangle is equal to the sum of the remote interior angles*

$x + x + 32 = 44$ Reason *substitution*

$x = 6$
 $y = 38$
 $m\angle DEA = 38^\circ$

Exploratory Challenge (15 minutes)

Display the theorem below for the class to see. Have the students state the theorem in their own words. Lead students through the first part of the proof of the theorem with leading questions, and then divide the class into partner groups. Have half of the groups prove why B' cannot be outside of the circle and half of the class prove why B' cannot be inside of the circle, then as a whole class, have groups present their work and discuss.

Do the following as a whole class:

THEOREM: If A, B, B' , and C are four points with B and B' on the same side of line \overleftrightarrow{AC} , and angles $\angle ABC$ and $\angle AB'C$ are congruent, then A, B, B' , and C all lie on the same circle.

- State this theorem in your own words, and write it on a piece of paper. Share it with a neighbor.
 - *If we have 2 points on a circle (A and C), and two points between those two points on the same side (B and B'), and if we draw two angles that are congruent ($\angle ABC$ and $\angle AB'C$), then all of the points (A, B, B', and C) lie on the same circle.*
- Let's start with points A, B , and C . Draw a circle containing points A, B , and C .
 - *Students draw a circle with points A, B, and C on the circle.*
- Draw $\angle ABC$.
 - *Students draw $\angle ABC$.*

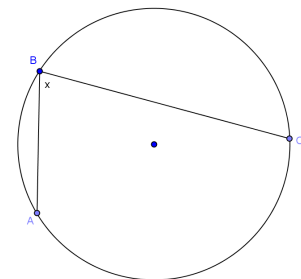

- Do we know the measure of $\angle ABC$?
 - No. If students want to measure it, remind them that all circles drawn by their classmates are different, so we are finding a general case.
- Since we don't know the measure of this angle, assign it to be the variable x , and label your drawing.
 - Students label diagram.
- In the theorem, we are told that there is another point B' . What else are we told about B' ?
 - B' lies on the same side of \overleftrightarrow{AC} as B .
 - $\angle ABC \approx \angle AB'C$
- What are we trying to prove?
 - B' lies on the circle too.

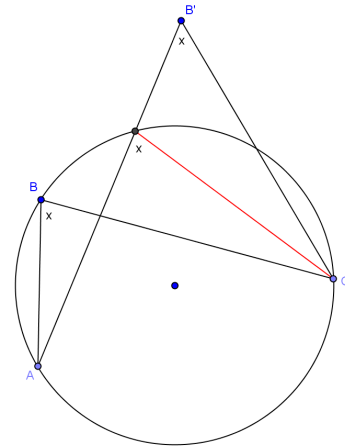

Assign half the class this investigation. Let them work in pairs, and provide leading questions as needed.

- Let's look at a case where B' is not on the circle. Where could B' lie?
 - Outside of the circle or inside the circle.
- Let's look at the case where it lies outside of the circle first. Draw B' outside of your circle and draw $\angle AB'C$.
 - Students draw B' and $\angle AB'C$.
- What is mathematically wrong with this picture?
 - Answers will vary. We want students to see that the inscribed angle formed where $\overline{AB'}$ intersects the circle has a measure of x since it is inscribed in the same arc as $\angle ABC$ not $\angle AB'C$. See diagram.
- To further clarify, have students draw the triangle $\triangle AB'C$ with the inscribed segment as shown. Further discuss what is mathematically incorrect with the angles marked x in the triangle.
- What can we conclude about B' ?
 - B' cannot lie outside of the circle.

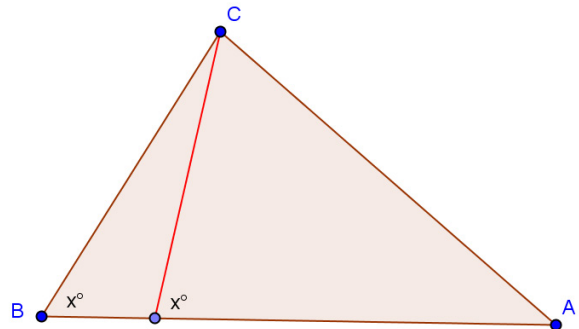

Assign the other half of the class this investigation. Let them work in pairs and provide leading questions as needed.

- Where else could B' lie?
 - In the circle or on the circle.
- With a partner, prove that B' cannot lie inside the circle using the steps above to guide you.
- Circle around as groups are working, and help where necessary, leading some groups if required.

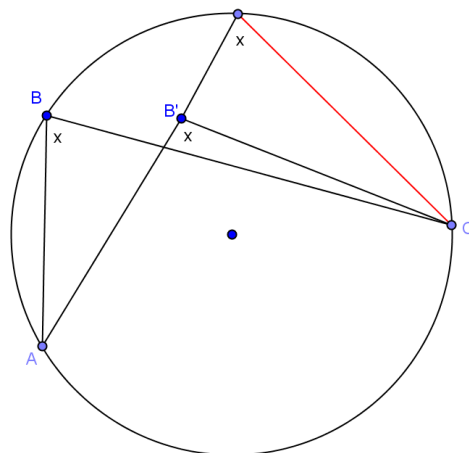

- Call the class back together, and allow groups to present their findings. Discuss both cases as a class.
- Have students do a 30-second Quick Write on what they just discovered.
 - *If $A, B, B',$ and C are 4 points with B and B' on the same side of the line \overleftrightarrow{AC} , and angles $\angle ABC$ and $\angle AB'C$ are congruent, then $A, B, B',$ and C all lie on the same circle.*

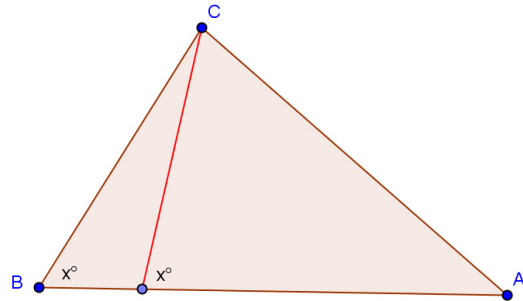

Exercises 1–4 (13 minutes)

Have students work through the problems (puzzles) below in pairs or homogeneous groups of three. Some groups may need one-on-one guidance. As students complete problems, have them summarize the steps that they took to solve each problem, then post solutions at 5-minute intervals. This will give groups that are stuck hints and show different methods for solving.

Exercises 1–4

Find the value x in each figure below, and describe how you arrived at the answer.

1. Hint: Thales' theorem

$m\angle BEC = 90^\circ$ inscribed in a semicircle
 $m\angle EBC = m\angle ECB = 45^\circ$ base angles of an isosceles triangle are congruent and sum of angles of a triangle = 180°
 $m\angle EBC = m\angle EDC = 45^\circ$ angles inscribed in the same arc are congruent
 $x = 45$

2.

$m\angle CBE = m\angle CAD = 34^\circ$ corresponding angles are congruent
 $m\angle BAD = 146^\circ$ linear pair with $\angle CAD$
 $m\angle ADE = \frac{1}{2} m\angle BAD = 73^\circ$ inscribed angle is half of measure of central angle intercepting same arc
 $x = 73$

3.

$m\angle BEC = m\angle CFB = \frac{1}{2}m\angle BAC = 52^\circ$
inscribed angles are half the measure of the central angle intercepting the same arc
 $m\angle DEG = 128^\circ$ *linear pair with $\angle BEC$*
 $m\angle GFD = 128^\circ$ *linear pair with $\angle CFB$*
 $m\angle EGF = 74^\circ$ *sum of angles of a quadrilateral*
 $m\angle FOC = 60^\circ$
 $x = 74$

4.

Draw center of circle, O.
 $\angle EOF = 2m\angle ECF = 60^\circ$
central angle double measure of inscribed angle intercepting same arc
 $m\angle DOC = 180^\circ$ *sum of angles of a circle = 360°*
 $x = 90$ *angle inscribed in a semicircle*

Closing (2 minutes)

Have students do a 30-second Quick Write of what they have learned about the inscribed angle theorem. Bring the class back together and debrief. Use this as a time to informally assess student understanding and clear up misconceptions.

- Write all that you have learned about the inscribed angle theorem.
 - *The measure of the central angle is double the measure of any inscribed angle that intercepts the same arc.*
 - *Inscribed angles that intercept the same arc are congruent.*

Lesson Summary

THEOREMS:

- **THE INSCRIBED ANGLE THEOREM:** The measure of a central angle is twice the measure of any inscribed angle that intercepts the same arc as the central angle
- **CONSEQUENCE OF INSCRIBED ANGLE THEOREM:** Inscribed angles that intercept the same arc are equal in measure.
- If A , B , B' , and C are four points with B and B' on the same side of line \overleftrightarrow{AC} , and angles $\angle ABC$ and $\angle AB'C$ are congruent, then A , B , B' , and C all lie on the same circle.

Relevant Vocabulary

- **CENTRAL ANGLE:** A *central angle* of a circle is an angle whose vertex is the center of a circle.
- **INSCRIBED ANGLE:** An *inscribed angle* is an angle whose vertex is on a circle, and each side of the angle intersects the circle in another point.
- **INTERCEPTED ARC:** An angle *intercepts* an arc if the endpoints of the arc lie on the angle, all other points of the arc are in the interior of the angle, and each side of the angle contains an endpoint of the arc. An angle inscribed in a circle intercepts exactly one arc; in particular, the arc intercepted by a right angle is the semicircle in the interior of the angle.

Exit Ticket (5 minutes)

Name _____

Date _____

Lesson 6: Unknown Angle Problems with Inscribed Angles in Circles

Exit Ticket

Find the measure of angles x and y . Explain the relationships and theorems used.

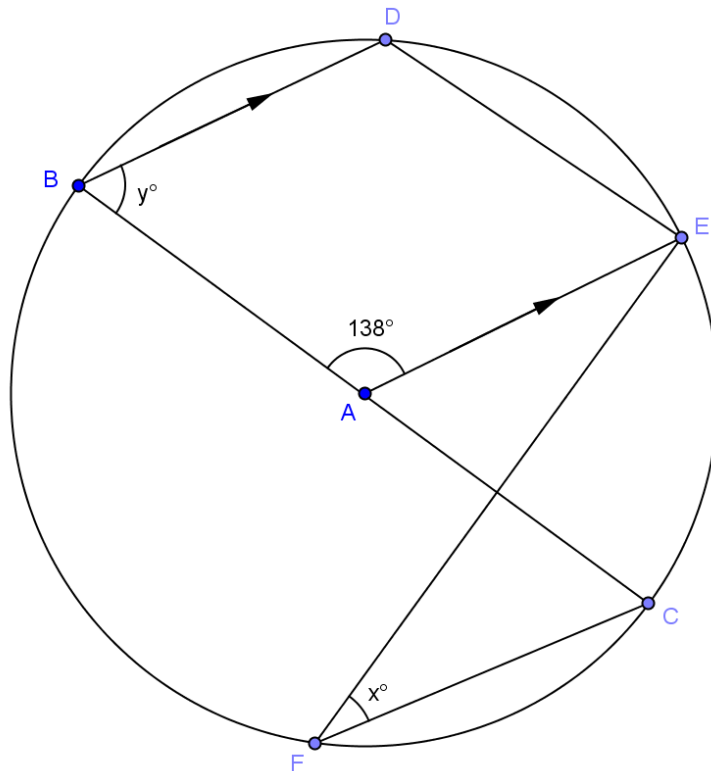

Exit Ticket Sample Solutions

Find the measures of angles x and y . Explain the relationships and theorems used.

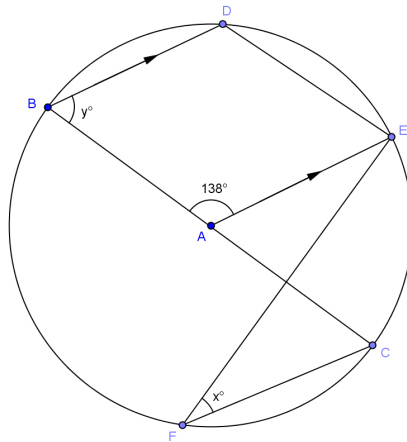

$m\angle EAC = 42^\circ$ (linear pair with $\angle BAE$). $m\angle EFC = \frac{1}{2}m\angle EAC = 21^\circ$ (inscribed angle is half measure of central angle with same intercepted arc). $x = 21$ $m\angle ABD = m\angle EAC = 42^\circ$ (corresponding angles are congruent)
 $y = 42$

Problem Set Sample Solutions

The first two problems are easier and require straightforward use of the inscribed angle theorem. The rest of the problems vary in difficulty but could be time consuming. Consider allowing students to choose the problems that they do and assigning a number of problems to be completed. You may want everyone to do Problem 8, as it is a proof with some parts of steps given as in the Opening Exercise.

In Problems 1–5, find the value x .

1.

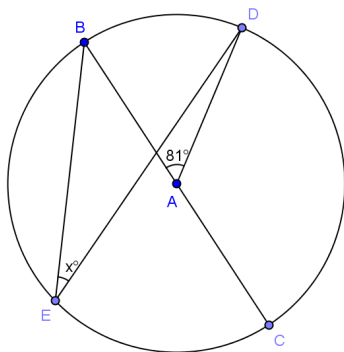

40.5

2.

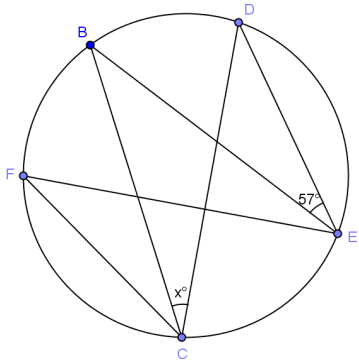

57

3.

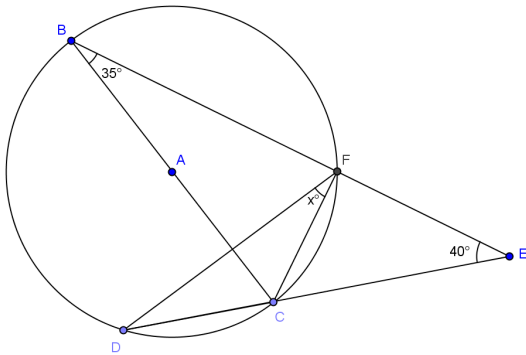

15

4.

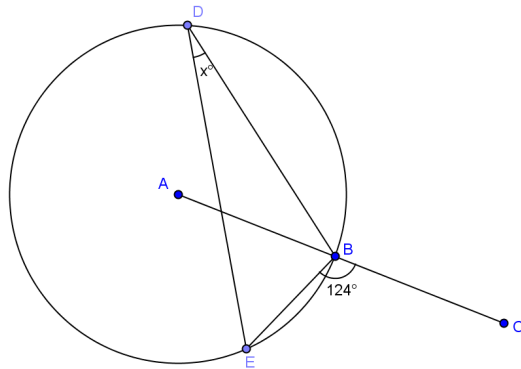

34

5.

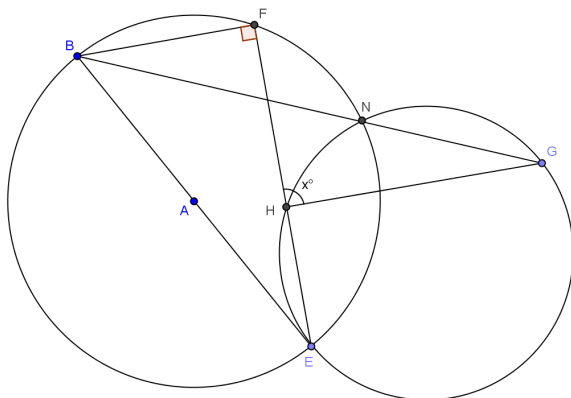

90

6. If $BF = FC$, express y in terms of x .

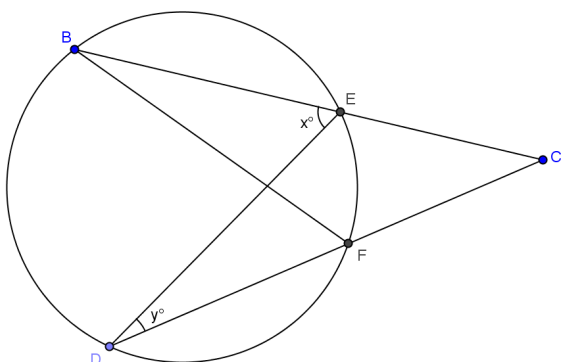

$y = 2x$

7.

a. Find the value x .

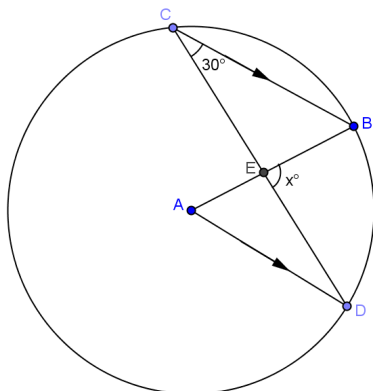

$x = 90$

b. Suppose the $m\angle C = a^\circ$. Prove that $m\angle DEB = 3a^\circ$.

$D = a$ (alt. angles congruent), $\angle A = 2a$ (inscribed angles half the central angle, $a + 2a + \angle AED = 180$ (angles of triangle = 180), $\angle AED = 180 - 3a$, $\angle AED + \angle BED = 180$ (angles form line), $180 - 3a + \angle BED = 180$ (substitution), $\angle BED = 3a$

8. In the figure below, three identical circles meet at B, F and C, E respectively. $BF = CE$. A, B, C and F, E, D lie on straight lines.

Prove $ACDF$ is a parallelogram.

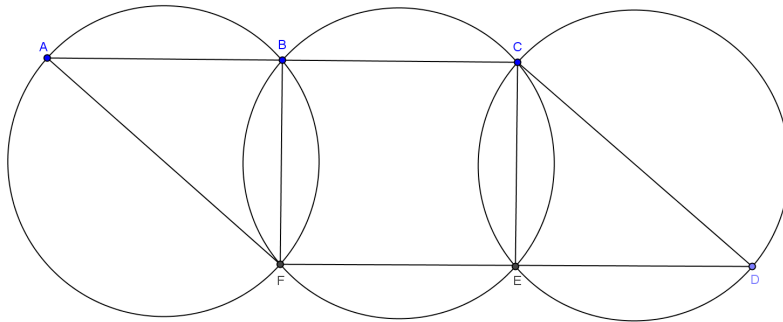

PROOF:

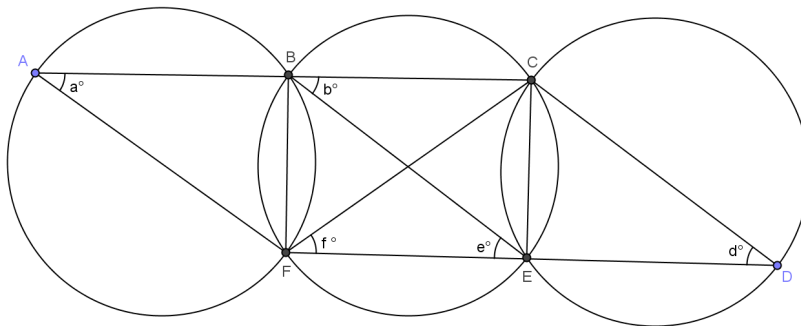

Join BE and CF .

$BF = CE$

Reason: _____

$a = \text{_____} = \text{_____} = \text{_____} = d$

Reason: _____

_____ = _____

$\overline{AC} \parallel \overline{FD}$ Alternate angles are equal.

_____ = _____

$\overline{AF} \parallel \overline{BE}$ Corresponding angles are equal.

_____ = _____

$\overline{BE} \parallel \overline{CD}$ Corresponding angles are equal.

$\overline{AF} \parallel \overline{BE} \parallel \overline{CD}$

$ACDF$ is a parallelogram.

Given; b, f, e , angles inscribed in congruent arcs are congruent; $\angle CBE = \angle FEB$; $\angle A = \angle CBE$; $\angle D = \angle BF$



Topic B:

Arcs and Sectors

G-C.A.1, G-C.A.2, G-C.B.5

Focus Standards:	G-C.A.1	Prove that all circles are similar.
	G-C.A.2	Identify and describe relationships among inscribed angles, radii, and chords. <i>Include the relationship between central, inscribed, and circumscribed angles; inscribed angles on a diameter are right angles; the radius of a circle is perpendicular to the tangent where the radius intersects the circle.</i>
	G-C.B.5	Derive using similarity the fact that the length of the arc intercepted by an angle is proportional to the radius, and define the radian measure of the angle as the constant of proportionality; derive the formula for the area of a sector.
Instructional Days:	4	
	Lesson 7:	The Angle Measure of an Arc (S) ¹
	Lesson 8:	Arcs and Chords (E)
	Lesson 9:	Arc Length and Areas of Sectors (P)
	Lesson 10:	Unknown Length and Area Problems (P)

In Topic B, students continue studying the relationships between chords, diameters, and angles and extend that work to arcs, arc length, and areas of sectors. Students use prior knowledge of the structure of inscribed and central angles together with repeated reasoning to develop an understanding of circles, secant lines, and tangent lines (MP.7). In Lesson 7, students revisit the inscribed angle theorem, this time stating it in terms of inscribed arcs (**G-C.A.2**). This concept is extended to studying similar arcs, which leads students to understand that all circles are similar (**G-C.A.1**). Students then look at the relationships between chords and subtended arcs and prove that congruent chords lie in congruent arcs. They also prove that arcs between parallel lines are congruent using transformations (**G-C.A.2**). Lessons 9 and 10 switch the focus from angles to arc length and areas of sectors. Students combine previously learned formulas for area and circumference of circles with concepts learned in this module to determine arc length, areas of sectors, and similar triangles (**G-C.B.5**). In Lesson 9, students are introduced to radians as the ratio of arc length to the radius of a circle. Lesson 10 reinforces these concepts with problems involving unknown length and area. Topic B requires that students use and apply prior knowledge to see the structure in new applications and to see the repeated patterns in these problems in order to arrive at theorems relating chords, arcs, angles, secant lines, and tangent lines to circles (MP.7). For example, students know that an inscribed angle has a measure of half the central angle intercepting the same arc. When they discover that the measure of a central angle is equal to

¹ Lesson Structure Key: P-Problem Set Lesson, M-Modeling Cycle Lesson, E-Exploration Lesson, S-Socratic Lesson

the angle measure of its intersected arc, they conclude that the measure of an inscribed angle is half the angle of its intercepted arc. Students then conclude that congruent arcs have congruent chords and that arcs between parallel chords are congruent.



Lesson 7: The Angle Measure of an Arc

Student Outcomes

- Define the *angle measure of arcs*, and understand that arcs of equal angle measure are similar.
- Restate and understand the *inscribed angle theorem* in terms of arcs: The measure of an *inscribed angle* is half the angle measure of its *intercepted arc*.
- Explain and understand that all circles are similar.

Lesson Notes

Lesson 7 introduces the angle measure of an arc and finishes the inscribed angle theorem. Only in this lesson is the inscribed angle theorem stated in full: “The measure of an inscribed angle is half the angle measure of its intercepted arc.” When we state the theorem in terms of the intercepted arc, the requirement that the intercepted arc is in the interior of the angle that intercepts it guarantees the measure of the inscribed angle is half the measure of the *central angle*. In Lesson 7, we will also calculate the measure of angles inscribed in obtuse angles. Lastly, we will address **G-C.A.1** and show that all circles are similar, a topic previously covered in Module 2, Lesson 14.

Classwork

Opening Exercise (5 minutes)

This Opening Exercise reviews the relationship between inscribed angles and central angles, concepts that need to be solidified before we introduce the last part of the inscribed angle theorem (arc measures). Have students complete the exercise individually and compare answers with a partner, then pull the class together to discuss. Be sure students can identify inscribed and central angles.

Opening Exercise

If the measure of $\angle GBF$ is 17° , name 3 other angles that have the same measure and explain why.

Answers will vary. $\angle GHF, \angle GCF, \angle GDF, \angle GEF$, they are all congruent because they are inscribed in the same arc.

What is the measure of $\angle GAF$? Explain.

34° ; it is the central angle with an inscribed arc of 17° . The measure of the central angle is double the measure of the inscribed angle of the same arc.

Can you find the measure of $\angle BAD$? Explain.

34° ; $\angle BAD$ and $\angle GAF$ are vertical angles and are congruent.

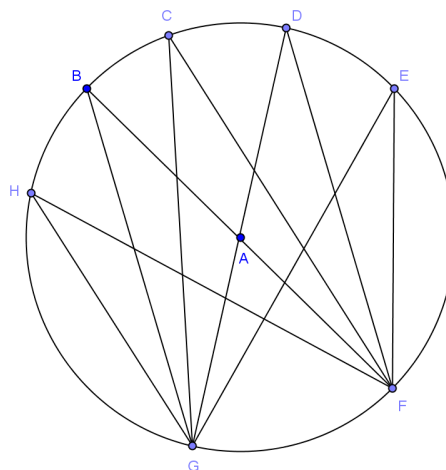

MP.3

Discussion (15 minutes)

This lesson begins with a full class discussion that ties what students know about central angles and inscribed angles to relating these angles to the arcs they are inscribed in, which is a new concept. In this discussion, we will define some properties of arcs. As properties are defined, list them on a board or large paper so students can see them.

- We have studied the relationship between central angles and inscribed angles. Can you help define an inscribed angle?
 - *An angle is inscribed in an arc if the sides of the angle contain the endpoints of the arc; the vertex of the angle is a point on the circle, but not an endpoint on the arc.*
- Can you help me define a central angle?
 - *Answers will vary. A central angle for a circle is an angle whose vertex is at the center of the circle.*
- Let's draw a circle with an acute central angle.
 - *Students draw a circle with an acute central angle.*
- Display the picture below.

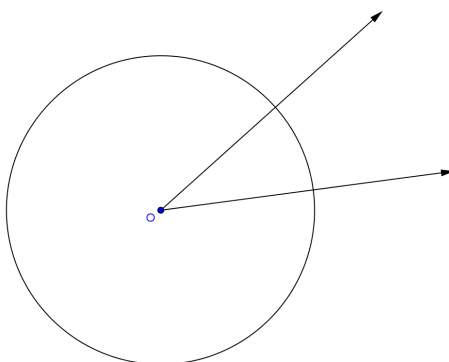

Scaffolding:

- Provide students a copy of the picture if they have difficulty creating the drawing.
- As definitions are given and as new terms are added, have students repeat each definition and term aloud.
- Create a definition wall.

- How many arcs does this central angle divide this circle into?
 - 2
- What do you notice about the two arcs?
 - *One is longer than the other is. One arc is contained in the angle and its interior, and one arc is contained in the angle and its exterior. (Students might say "inside the angle" or "outside the angle." Help them to state it precisely.)*
- In a circle with center O , let A and B be different points that lie on the circle but are not the endpoints of a diameter. The minor arc between A and B is the set containing A , B , and all points of the circle that are in the interior of $\angle AOB$.
- Explain to your neighbor what a minor arc is, and write the definition.

Scaffolding:

- Provide students a graphic organizer for arcs (major and minor).
- For ELL students, do choral repetition of major and minor arcs using hand gestures (arms wide for major and close together for minor).

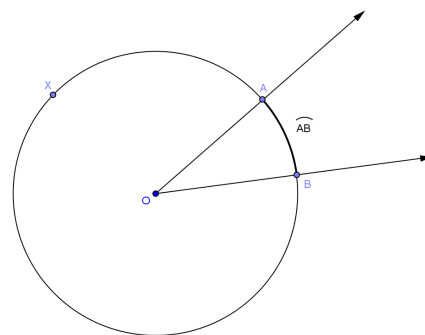

- The way we show a minor arc using mathematical symbols is \widehat{AB} (AB with an arc over them). Write this on your drawing.
- Can you predict what we call the larger arc?
 - *The major arc.*
- Now, let's write the definition of a major arc.
 - In a circle with center O , let A and B be different points that lie on the circle but are not the endpoints of a diameter. The *major arc* is the set containing A , B , and all points of the circle that lie in the exterior of $\angle AOB$.
- Can we call it \widehat{AB} ?
 - *No, because we already called the minor arc \widehat{AB} .*
- We would write the major arc as \widehat{AXB} where X is any point on the circle outside of the central angle. Label the major arc.
- Can you define a *semicircle* in terms of arc?
 - In a circle, let A and B be the endpoints of a diameter. A semicircle is the set containing A , B , and all points of the circle that lie in a given half-plane of the line determined by the diameter.
- If I know the measure of $\angle AOB$, what do you think the angle measure of \widehat{AB} is?
 - *The same measure.*
- Let's say that statement.
 - *The angle measure of a minor arc is the measure of the corresponding central angle.*
- What do you think the angle measure of a semicircle is? Why?
 - *180° . It is half a circle, and a circle measures 360° .*
- Now let's look at \widehat{AXB} . If the angle measure of \widehat{AB} is 20° , what do you think the angle measure of \widehat{AXB} would be? Explain.
 - *340° because it is the other part of the circle not included in the 20° . Since a full circle is 360° , the part not included in the 20° would equal 340° .*
- Discuss what we have just learned about minor and major arcs and semicircles and their measures with a partner.
- Look at the diagram. If \widehat{AB} is 20° , can you find the angle measure of \widehat{CD} and \widehat{EF} ? Explain.
 - *All are 20° because they all have the same central angle. The circles are dilations of each other, so angle measurement is conserved and the arcs are similar.*
- We are discussing angle measure of the arcs, not length of the arcs. Angle measure is only the amount of turning that the arc represents, not how long the arc is. Arcs of different lengths can have the same angle measure. Two arcs (of possibly different circles) are similar if they have the same angle measure. Two arcs in the same or congruent circles are congruent if they have the same angle measure.
- Explain these statements to your neighbor. Can you prove it?

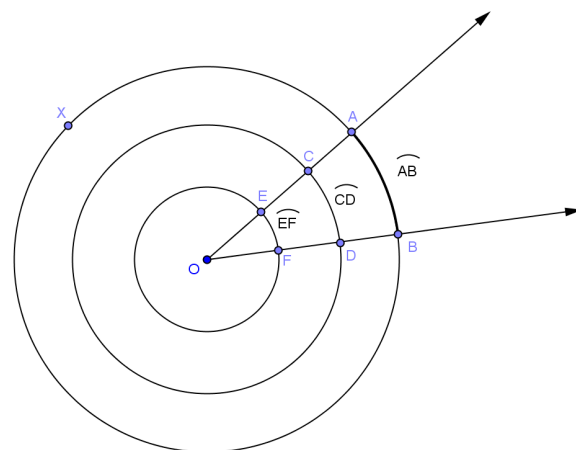

- In this diagram, I can say that \widehat{BC} and \widehat{CD} are adjacent. Can you write a definition of adjacent arcs?
 - *Two arcs on the same circle are adjacent if they share exactly one endpoint.*
- If $\widehat{BC} = 25^\circ$ and $\widehat{CD} = 35^\circ$, what is the angle measure of \widehat{BD} ? Explain.
 - *60° . Since they were adjacent, together they create a larger arc whose angle measures can be added together. Or, calculate the measure of the arc as $360 - (25 + 35)$, as the representation could be from B to D without going through point C.*
- This is a parallel to the 180 protractor axiom (angles add). If \widehat{AB} and \widehat{BC} are adjacent arcs, then $m\widehat{AC} = m\widehat{AB} + m\widehat{BC}$.
- Central angles and inscribed angles intercept arcs on a circle. An angle intercepts an arc if the endpoints of the arc lie on the angle, all other points of the arc are in the interior of the angle, and each side of the angle contains an endpoint of the arc.
- Draw a circle and an angle that intercepts an arc and an angle that does not. Explain your drawing to your neighbor.
 - *Answers will vary.*

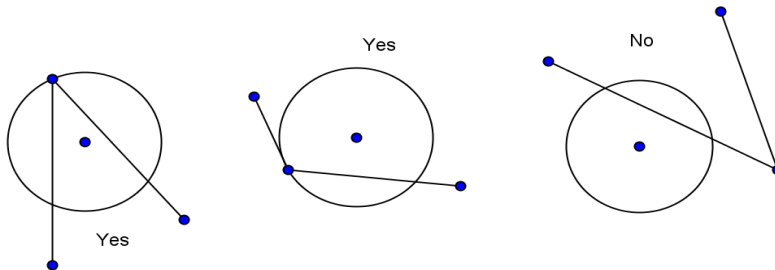
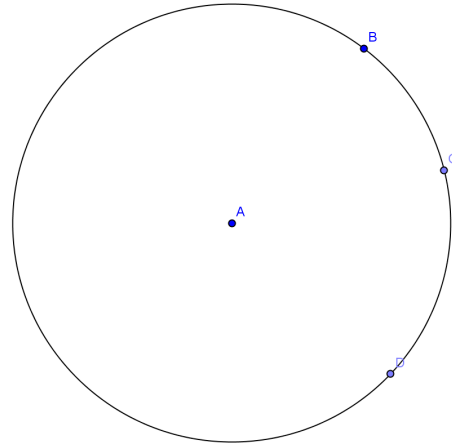

- Tell your neighbor the relationship between the measure of a central angle and the measure of the inscribed angle intercepting the same arc.
 - *The measure of the central angle is double the measure of any inscribed angle that intercepts the same arc.*
- Using what we have learned today, can you state this in terms of the measure of the intercepted arc?
 - *The measure of an inscribed angle is half the angle measure of its intercepted arc. The measure of a central angle is equal to the angle measure of its intercepted arc.*

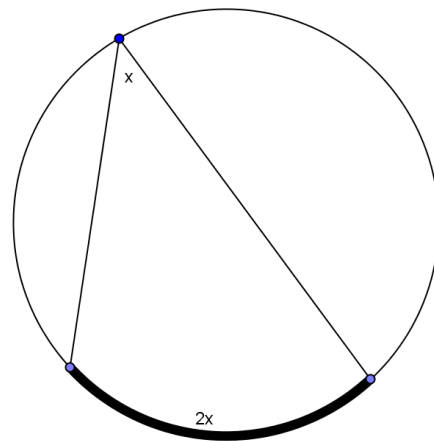

Example 1 (8 minutes)

This example extends the inscribed angle theorem to obtuse angles; it also shows the relationship between the measure of the intercepted arc and the inscribed angle. Students will need a protractor.

Example 1

What if we started with an angle inscribed in the minor arc between A and C ?

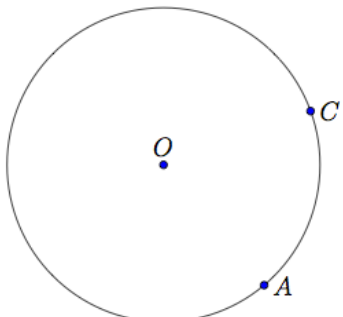

- Draw a point B on the minor arc between A and C .
 - *Students draw point B .*
- Draw the arc intercepted by $\angle ABC$? Make it red in your diagram.
 - *Students draw the arc and color it red.*
- In your diagram, do you think the measure of an arc between A and C is half of the measure of the inscribed angle? Why or why not?
 - *The phrasing and explanations can vary. However, there is one answer; the measure of the inscribed arc is twice the measure of the inscribed angle.*
- Using your protractor, measure $\angle ABC$. Write your answer on your diagram.
 - *Answers will vary.*
- Now measure the arc in degrees. Students may struggle with this, so ask...
- Can you think of an easier way to measure this arc in degrees?
 - *We could measure $\angle AOC$, and then subtract that measure from 360°*
- Write the measure of the arc in degrees on your diagram.
- Do your measurements support the inscribed angle theorem? Why or why not?
 - *Yes, the measure of the inscribed angle is half the measure of its intercepted arc.*
- Compare your answer and diagram to your neighbor's answer and diagram.

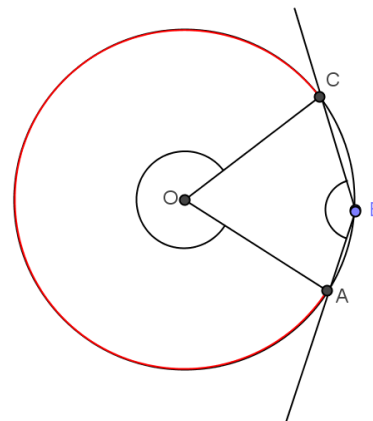

- Restate the inscribed angle theorem in terms of intercepted arcs.
 - *The measure of an inscribed angle is half the angle measure of its intercepted arc.*

Scaffolding:

- Help students see the connection between the central angles and inscribed angle by color-coding.
- Outline central angle in red.
- Outline the inscribed angle that has the same intercepted arc as the central angle in blue.

Exercises 1–4 (5 minutes)

1. In circle A, $\widehat{BC} : \widehat{CE} : \widehat{ED} : \widehat{DB} = 1 : 2 : 3 : 4$. Find

a. $m\angle BAC$
 36°

b. $m\angle DAE$
 108°

c. $m\widehat{DB}$
 144°

d. $m\widehat{CED}$
 180°

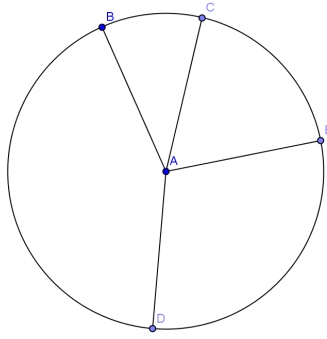

2. In circle B, $AB = CD$. Find

a. $m\widehat{CD}$
 60°

b. $m\widehat{CAD}$
 300°

c. $m\widehat{AD}$
 180°

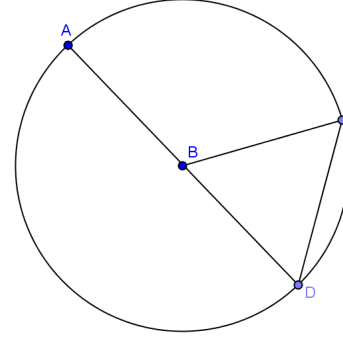

3. In circle A, \overline{BC} is a diameter and $m\angle DAC = 100^\circ$. If $m\widehat{EC} = 2m\widehat{BD}$, find

a. $m\angle BAE$
 20°

b. $m\widehat{EC}$
 160°

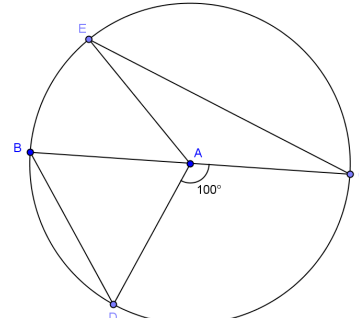

c. $m\widehat{DEC}$
 260°

4. Given circle A with $m\angle CAD = 37^\circ$, find

a. $m\widehat{CBD}$
 323°

b. $m\angle CBD$
 18.5°

c. $m\angle CED$
 161.5°

Example 2 (4 minutes)

In this example, students will ponder the question, “Are all circles similar?” This is intuitive but easy to show, as the ratio of the circumference of two circles is equal to the ratio of the diameters and the ratio of the radii.

- Project the circle at right on the board.
- What is the circumference of this circle in terms of radius, r ?
 - $2\pi r$
- What if we double the radius, what is the circumference?
 - $2\pi(2r) = 4\pi$
- What if we triple the original radius, what is the circumference?
 - $2\pi(3)r = 6\pi$
- What determines the circumference of a circle? Explain.
 - *The radius. The only variable in the formula is r (radius), so as radius changes, the size of the circle changes.*
- Does the shape of the circle change? Explain.
 - *All circles have the same shape; they are just different sizes depending on the length of the radius.*
- What does this mean is true of all circles?
 - *All circles are similar.*

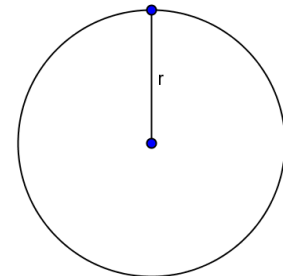

Closing (3 minutes)

Call class together, and show the diagram.

- Express the measure of the central angle and the inscribed angle in terms of the angle measure x° .
 - *The central angle $\angle CAD$ has a measure of x° .*
 - *The inscribed angle $\angle CBD$ has a measure of $\frac{1}{2}x^\circ$.*
- State the inscribed angle theorem to your neighbor.
 - *The measure of an inscribed angle is half the angle measure of its intercepted arc.*

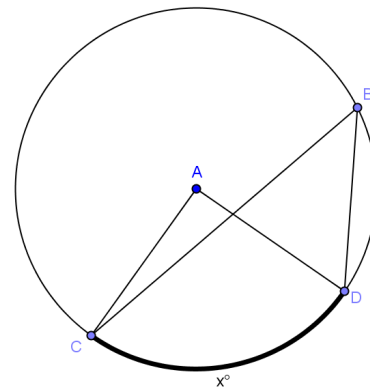

Lesson Summary

THEOREMS:

- **INSCRIBED ANGLE THEOREM:** The measure of an inscribed angle is half the measure of its intercepted arc.
- **Two arcs (of possibly different circles) are similar if they have the same angle measure. Two arcs in the same or congruent circles are congruent if they have the same angle measure.**
- **All circles are similar.**

Relevant Vocabulary

- **ARC:** An *arc* is a portion of the circumference of a circle.
- **MINOR AND MAJOR ARC:** Let C be a circle with center O , and let A and B be different points that lie on C but are not the endpoints of the same diameter. The *minor arc* is the set containing A , B , and all points of C that are in the interior of $\angle AOB$. The *major arc* is the set containing A , B , and all points of C that lie in the exterior of $\angle AOB$.
- **SEMICIRCLE:** In a circle, let A and B be the endpoints of a diameter. A *semicircle* is the set containing A , B , and all points of the circle that lie in a given half-plane of the line determined by the diameter.
- **INSCRIBED ANGLE:** An *inscribed angle* is an angle whose vertex is on a circle and each side of the angle intersects the circle in another point.
- **CENTRAL ANGLE:** A *central angle* of a circle is an angle whose vertex is the center of a circle.
- **INTERCEPTED ARC OF AN ANGLE:** An angle *intercepts* an arc if the endpoints of the arc lie on the angle, all other points of the arc are in the interior of the angle, and each side of the angle contains an endpoint of the arc.

Exit Ticket (5 minutes)

Name _____

Date _____

Lesson 7: Properties of Arcs

Exit Ticket

1. Given circle A with diameters \overline{BC} and \overline{DE} and $m\widehat{CD} = 56^\circ$.

- Name a central angle.
- Name an inscribed angle.
- Name a chord that is not a diameter.
- What is the measure of $\angle CAD$?
- What is the measure of $\angle CBD$?
- Name 3 angles of equal measure.
- What is the degree measure of \widehat{CDB} ?

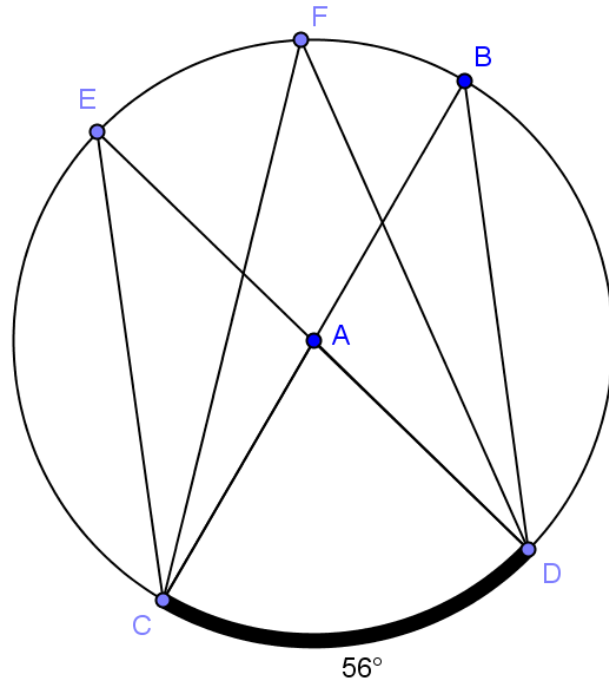

Exit Ticket Sample Solutions

1. Given circle A with diameters \overline{BC} and \overline{DE} and $m\widehat{CD} = 56^\circ$

- Name a central angle.
 $\angle CAD$
- Name an inscribed angle.
Answers will vary. $\angle CED$.
- Name a chord that is not a diameter.
Answers will vary. \overline{CE} .
- What is the measure of $\angle CAD$?
 56°
- What is the measure of $\angle CBD$?
 28°
- Name 3 angles of equal measure.
 $m\angle CED = m\angle CFD = m\angle CBD$
- What is the degree measure of \widehat{CDB} ?
 180°

Problem Set Sample Solutions

The first two problems are easier and require straightforward use of the inscribed angle theorem. The rest of the problems vary in difficulty, but could be time consuming. Consider allowing students to choose the problems that they do and assigning a number of problems to be completed. You may want everyone to do Problem 8, as it is a proof with some parts of steps given as in the Opening Exercise.

1. Given circle A with $m\angle CAD = 50^\circ$,

a. Name a central angle.

$\angle CAD$

b. Name an inscribed angle.

$\angle CBD$

c. Name a chord.

Answers will vary. \overline{BD}

d. Name a minor arc.

Answers will vary. \widehat{CD}

e. Name a major arc.

\widehat{CBD}

f. Find $m\widehat{CD}$,

50°

g. Find $m\widehat{CBD}$.

310°

h. Find $m\angle CBD$.

25°

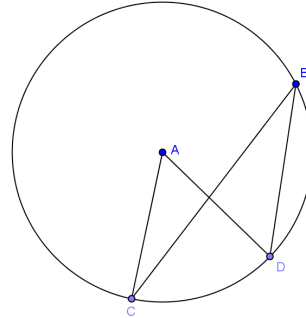

2. Given circle A , find the measure of each minor arc.

$m\widehat{BE} = 64^\circ$

$m\widehat{CD} = 64^\circ$

$m\widehat{CE} = 116^\circ$

$m\widehat{BD} = 116^\circ$

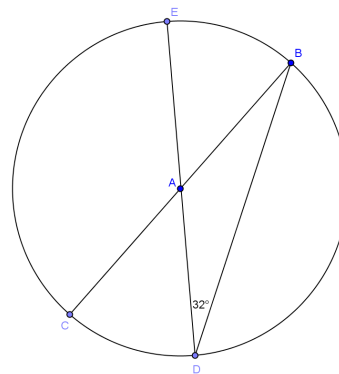

3. Given circle A , find

a. $m\angle BAD$

100°

b. $m\angle CAB$

80°

c. $m\widehat{BC}$

80°

d. $m\widehat{BD}$

100°

e. $m\widehat{BCD}$

260°

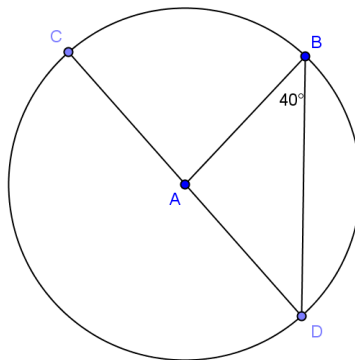

4. Find the angle measure of angle x .

33°

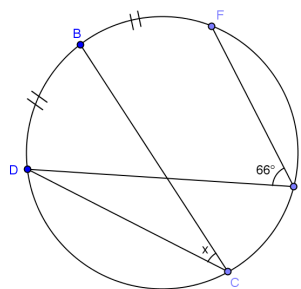

5. In the figure, $m\angle BAC = 126^\circ$ and $m\angle BED = 32^\circ$. Find $m\angle DEC$.

85°

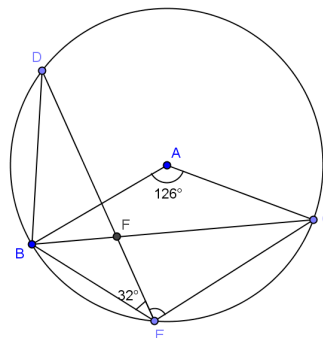

6. In the figure $m\angle BCD = 74^\circ$, and $m\angle BDC = 42^\circ$. K is the midpoint of \widehat{CB} and J is the midpoint of \widehat{BD} . Find $m\angle KBD$ and $m\angle CKJ$.

Solution: Join $BK, KC, KD, KJ, JC,$ and JD .

$m\widehat{BK} = m\widehat{KC}$ _____

$m\angle KDC = \frac{42}{2} = 21^\circ$ _____

$a =$ _____

In $\triangle BCD$, $b =$ _____

$c =$ _____

$m\widehat{BJ} = m\widehat{JD}$ _____

$m\angle JCD =$ _____

$d =$ _____

$m\angle KBD = a + b =$ _____

$m\angle CKJ = c + d =$ _____

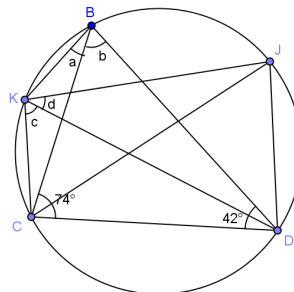
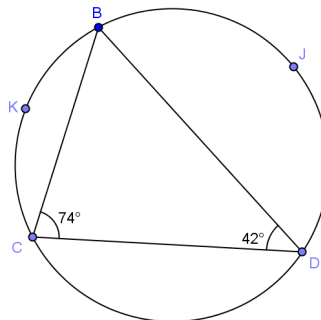

Midpoint forms congruent arcs; angle bisector; 21° , congruent angles inscribed in same arc; 64° , sum of angles of triangle = 180° ; 64° , congruent angles inscribed in same arc; 37° , angle bisector; 37° , congruent angles inscribed in same arc; 85° ; 91° .



Lesson 8: Arcs and Chords

Student Outcomes

- Congruent chords have congruent arcs, and the converse is true.
- Arcs between parallel chords are congruent.

Lesson Notes

In this lesson, students use concepts studied earlier in this module to prove three new concepts: Congruent chords have congruent arcs; congruent arcs have congruent chords; arcs between parallel chords are congruent. The proofs are designed for students to be able to begin independently, so this is a great lesson to allow students the freedom to try a proof with little help getting started.

This lesson that highlights MP.7 as students study different circle relationships and draw auxiliary lines and segments. MP.1 and MP.3 are also highlighted as students attempt a series of proofs without initial help from the teacher.

Classwork

Opening Exercise (5 minutes)

The Opening Exercise reminds students of our work in Lesson 2 relating circles, chords, and radii. It sets the stage for Lesson 8. Have students try this exercise on their own, then compare answers with a neighbor, particularly the explanation of their work. Bring the class back together, and have a couple of students present their work and do a quick review.

Opening Exercise

Given circle A with $\overline{BC} \perp \overline{DE}$, $FA = 6$, and $AC = 10$. Find BF and DE .
Explain your work.

$BF = 4$, $DE = 16$.

AB is a radius with a measure of 10. If $FA = 6$, then $BF = 10 - 6 = 4$.

Connect AD and AE . In $\triangle DAE$, $AD = AE = 10$. Both $\triangle DFA$ and $\triangle EFA$ are right triangles and congruent, so by the Pythagorean theorem,

$DF = FE = 8$, making $DE = 16$.

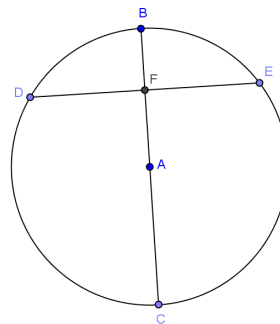

MP.7
&
MP.1

Exploratory Challenge (12 minutes)

In this example, students will use what they have learned about the relationships between chords, radii, and arcs to prove that congruent chords have congruent arcs and congruent minor arcs have congruent chords. They will then extend this to include major arcs. We are presenting the task and then letting students think through the first proof. Give students time to struggle and talk with their groups. This is not a difficult proof and can be done with concepts from Lesson 2 that they are familiar with or by using rotation. Once groups finish and talk about the first proof, they then do two more proofs that are similar. Walk around, and give help where needed, but not too quickly.

Display the picture below to the class.

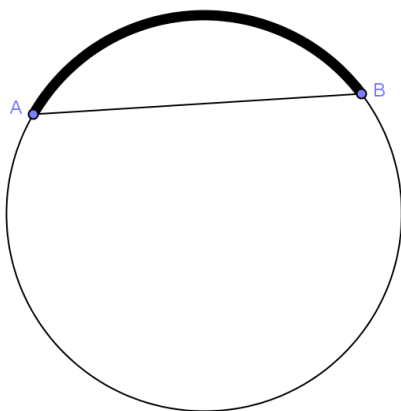

- Tell me what you see in this diagram.
 - *A circle, a chord, a minor arc, a major arc.*
- What do you notice about the chord and the minor arc?
 - *They have the same endpoints.*
- We say that arc \widehat{AB} is subtended by chord \overline{AB} . Can you repeat that with me?
 - *Arc \widehat{AB} is subtended by chord \overline{AB} .*
- What do you think we mean by the word “subtended”?
 - *The chord cuts the circle and forms the arc. The chord and arc have the same endpoints.*
- Display circle at right. What can we say about arc \widehat{CD} ?
 - *Arc \widehat{CD} is subtended by chord \overline{CD} .*
- If $AB = CD$, what do you think would be true about $m\widehat{AB}$ and $m\widehat{CD}$?
 - *They are equal (congruent).*

Scaffolding:

- Display the theorems, axioms, and definitions that we have studied in this module on a word wall.
- Chorally repeat the definitions as a class.

Scaffolding:

- If groups are struggling with the proof, give them the following leading questions and steps:
- Draw a picture of the problem.
- Draw two triangles, one joining the center to each chord.
- What is true about the sides of the triangle connected to the center of the circle?
- Are the triangles congruent? How?
- What does that mean about the central angles?
- If we say the central angle has a measure of x° , what is the measure of each chord?
- Think about what we know about rotating figures, will that help us?
- Try drawing a picture.

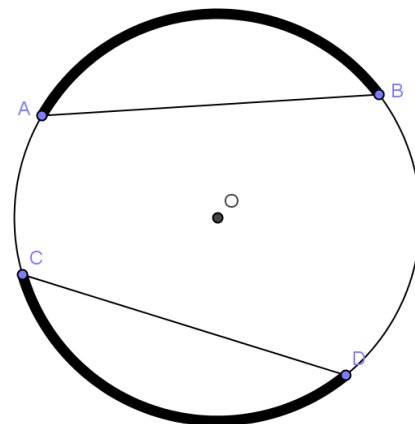

Put students in heterogeneous groups of three, and present the task. Set up a 5-minute check to be sure that groups are on the right path and to give ideas to groups who are struggling. Have groups show their work on large paper or poster board and display work, then have a whole class discussion showing the various ways to achieve the proof.

- With your group, prove that if the chords are congruent, the arcs subtended by those chords are congruent.
 - *Some groups will use rotations and others similar triangles similar to the work that was done in Lesson 2. Both ways are valid and sharing will expose students to each method.*
- Now prove that in a circle congruent minor arcs have congruent chords.
 - *Students should easily see that the process is almost the same, and that it is indeed true.*
- Do congruent major arcs have congruent chords too?
 - *Since major arcs are the part of the circle not included in the minor arc, if minor arcs are congruent, 360° minus the measure of the minor arc will also be the same.*

Exercise 1 (5 minutes)

Have students try Exercise 1 individually, and then do a pair-share. Wrap up with a quick whole class discussion.

Exercises

1. Given circle A with $m\widehat{BC} = 54^\circ$ and $\angle CDB \cong \angle DBE$, find $m\widehat{DE}$. Explain your work.

$m\widehat{DE} = 54^\circ$. $m\angle CAB = 5^\circ$ because the central angle has the same measure as its subtended arc. $m\angle CDB = 27^\circ$ because an inscribed angle has half the measure of the central angle with the same inscribed arc. Since $\angle CDB \cong \angle DBE$, $m\widehat{DE} = 54^\circ$ because it is double the angle inscribed in it.

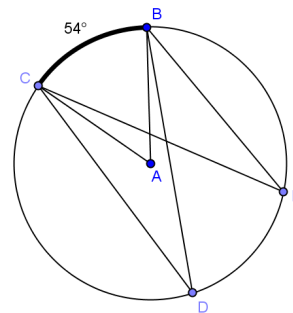

Example 1 (5 minutes)

In this example, students prove that arcs between parallel chords are congruent. This is a teacher led example. Students will need a compass and straight edge to construct a diameter and a copy of the circle below.

Scaffolding:

- For advanced learners, display the picture below, and ask them to prove the theorem without the provided questions, and then present their proofs in class.

Display the picture at right to the class.

- What do you see in this diagram?
 - *A circle, two arcs, a pair of parallel chords*
- What looks to be true about the arcs?
 - *They appear to be congruent.*
- This is true, and here is the theorem: *In a circle, arcs between parallel chords are congruent.*
- Repeat that with me.
 - *In a circle, arcs between parallel chords are congruent.*
- Let's prove this together. Construct a diameter perpendicular to the parallel chords.
 - *Students construct the perpendicular diameter.*
- What does this diameter do to each chord?
 - *The diameter bisects each chord.*
- Reflect across the diameter (or fold on the diameter). What happens to the endpoints?
 - *The reflection takes the endpoints on one side to the endpoints on the other side. It therefore takes arc to arc. Distances from the center are preserved.*
- What have we proven?
 - *Arcs between parallel chords are congruent.*
- Draw \overline{CD} . Can you think of another way to prove this theorem using properties of angles formed by parallel lines?
 - *$m\angle BCD = m\angle EDC$ because alternate interior angles are congruent. This means $m\widehat{CE} = m\widehat{BD}$ both have inscribed angles of the same measure, so the arc angle measures are congruent and twice the measure of their inscribed angles.*

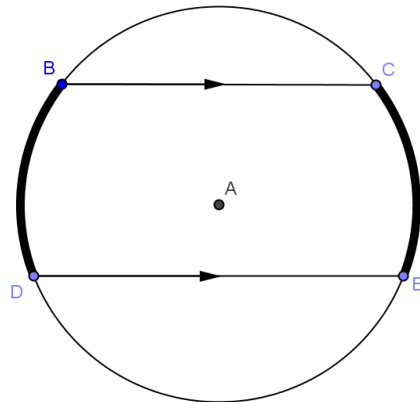

Exercise 2 (5 minutes)

Have students work on Exercise 2 in pairs. This exercise requires use of all concepts studied today. Pull the class back together to share solutions. Use this as a way to assess student understanding.

2. If two arcs in a circle have the same measure, what can you say about the quadrilateral formed by the four endpoints? Explain.

If the arcs are congruent, their endpoints can be joined to form chords that are parallel ($\overline{BC} \parallel \overline{DE}$).

The chords subtending the congruent arcs are congruent ($\overline{BD} \parallel \overline{CE}$).

A quadrilateral with one pair of opposite sides parallel and the other pair of sides congruent is an isosceles trapezoid.

Scaffolding:

- Review the properties of quadrilaterals.
- For students who can't picture the figure, provide them with this diagram.

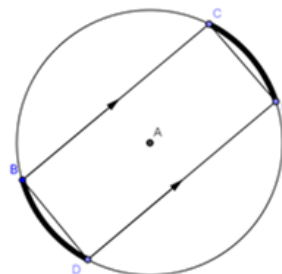

Exercises 3–5 (5 minutes)

3. Find the angle measure of \widehat{CD} and \widehat{ED} .

$m\widehat{CD} = 130^\circ, m\widehat{ED} = 50^\circ$

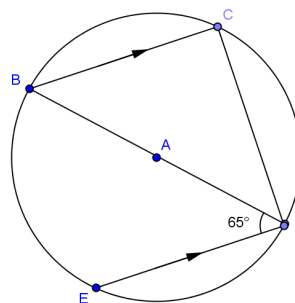

4. $m\widehat{CB} = m\widehat{ED}$ and $m\widehat{BC} : m\widehat{BD} : m\widehat{EC} = 1 : 2 : 4$. Find

a. $m\angle BCF$

45°

b. $m\angle EDF$

90°

c. $m\angle CFE$

135°

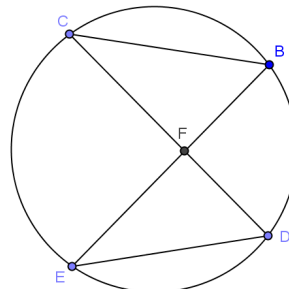

5. \overline{BC} is a diameter of circle A . $m\widehat{BD} : m\widehat{DE} : m\widehat{EC} = 1 : 3 : 5$. Find

- $m\widehat{BD}$
 20°
- $m\widehat{DEC}$
 160°
- $m\widehat{ECB}$
 280°

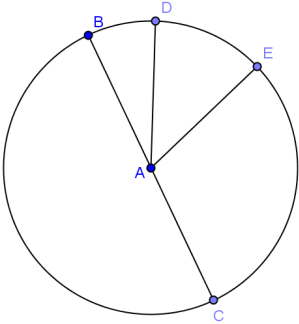

Closing (3 minutes)

Have students do a 30-second Quick Write on what they have learned in this lesson about chords and arcs. Pull the class together to review, and have them add these to the circle graphic organizer started in Lesson 2.

- Congruent chords have congruent arcs.
- Congruent arcs have congruent chords.
- Arcs between parallel chords are congruent.

Lesson Summary

THEOREMS:

- Congruent chords have congruent arcs.
- Congruent arcs have congruent chords.
- Arcs between parallel chords are congruent.

Exit Ticket (5 minutes)

Name _____

Date _____

Lesson 8: Arcs and Chords

Exit Ticket

1. Given circle A with radius 10, prove $BE = DC$.

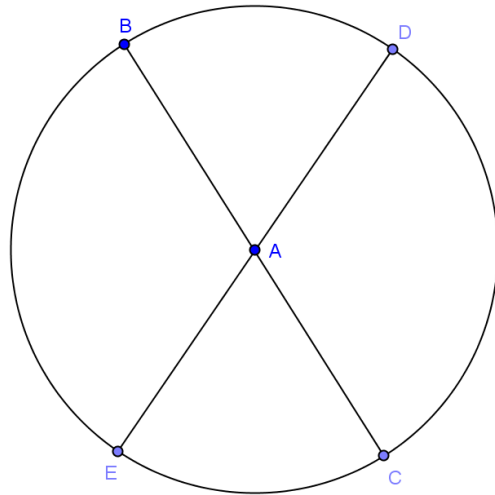

2. Given the circle at right, find $m\widehat{BD}$.

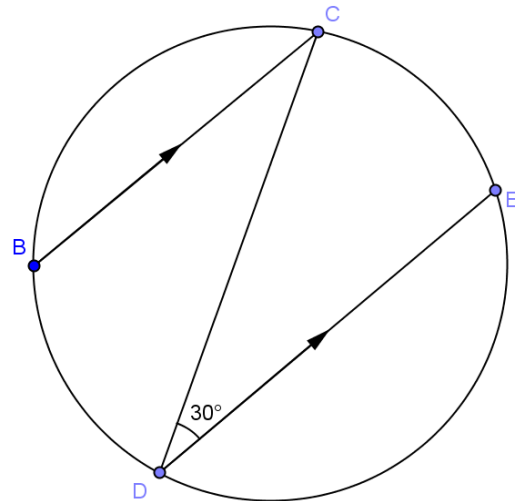

Exit Ticket Sample Solutions

1. Given circle A with radius 10, prove $BE = DC$.

$m\angle BAE = m\angle DAC$ (vertical angles are congruent)

$m\widehat{BE} = m\widehat{DC}$ (arcs are equal in degree measure to their inscribed central angles)

$BE = DC$ (chords are equal in length if they subtend congruent arcs)

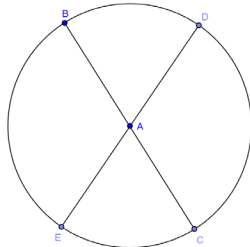

2. Given the circle at right, find $m\widehat{BD}$.

60°

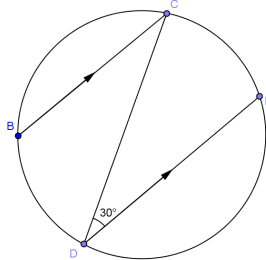

Problem Set Sample Solutions

Problems 1–3 are straightforward and easy entry. Problems 5–7 are proofs and may be challenging for some students. You may consider only assigning some problems or allowing student choice while requiring some problems of all students.

1. Find

a. $m\widehat{CE}$
 70°

b. $m\widehat{BD}$
 70°

c. $m\widehat{ED}$
 40°

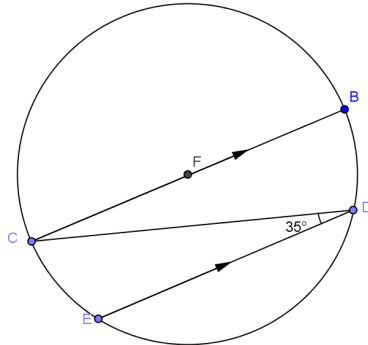

2. In circle A , \overline{BC} is a diameter, $m\widehat{CE} = m\widehat{ED}$, and $m\angle CAE = 32^\circ$.

a. Find $m\angle CAD$.

64°

b. Find $m\angle ADC$.

58°

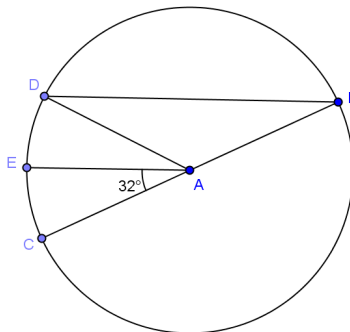

3. In circle A , \overline{BC} is a diameter, $2m\widehat{CE} = m\widehat{ED}$, and $\overline{BC} \parallel \overline{DE}$. Find $m\angle CDE$.

22.5°

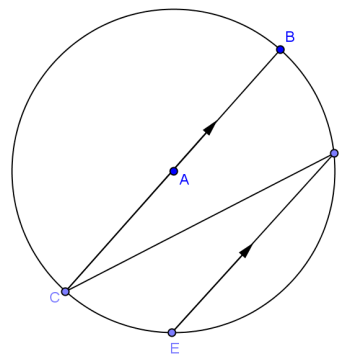

4. In circle A , \overline{BC} is a diameter and $\widehat{CE} = 68^\circ$.

a. Find $m\widehat{CD}$.

68°

b. Find $m\angle DBE$.

68°

c. Find $m\angle DCE$

112°

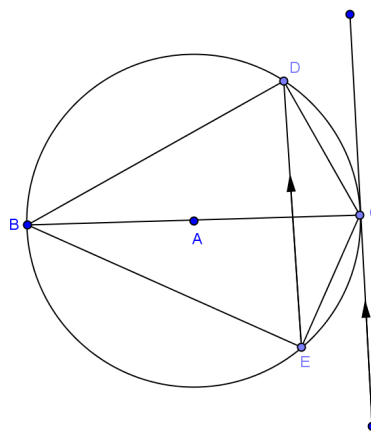

5. In the circle given, $\widehat{BC} \cong \widehat{ED}$. Prove $\overline{BE} \cong \overline{DC}$

Join \overline{CE} .

$BC = ED$ (congruent arcs have chords equal in length)

$m\angle CBE = m\angle EDC$ (angles inscribed in same arc are equal in measure)

$m\angle BCE = m\angle DEC$ (angles inscribed in congruent arcs are equal in measure)

$\triangle BCE \cong \triangle DEC$ (AAS)

$\overline{BE} \cong \overline{DC}$ (corresponding sides of congruent triangles are congruent)

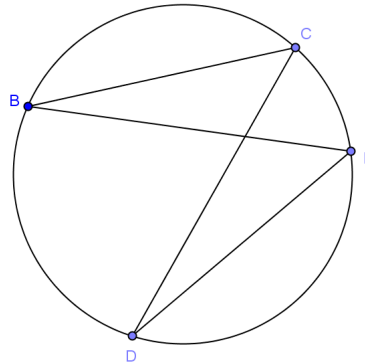

6. Given circle A with $\overline{AD} \parallel \overline{CE}$, show $\widehat{BD} \cong \widehat{DE}$.

Join \overline{BD} , \overline{DE} , \overline{AE} .

$\overline{AC} = \overline{AE} = \overline{AD} = \overline{AB}$ (radii)

$\angle AEC \cong \angle ACE$, $\angle AED \cong \angle ADE$, $\angle ADB \cong \angle ABD$ (base angles of isosceles triangles are congruent)

$\angle AEC \cong \angle EAD$ (Alternate interior angles are congruent)

$m\angle ADE + m\angle DEA + m\angle EAD = 180^\circ$ (sum of angles of \triangle)

$3m\angle AED = 180^\circ$ (substitution)

$m\angle AED = 60^\circ$ $\triangle BAD \cong \triangle DAE \cong \triangle EAC$ (SAS)

$BD = DE$ (corresponding parts of congruent triangles)

$\widehat{BD} \cong \widehat{DE}$ (arcs subtended by congruent chords)

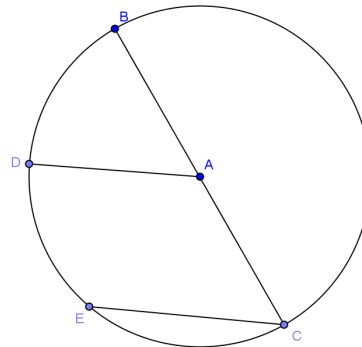

7. In circle A , \overline{AB} is a radius and $\widehat{BC} \cong \widehat{BD}$ and $m\angle CAD = 54^\circ$. Find $m\angle ABC$. Complete the proof.

$BC = BD$ _____

$m\angle$ _____ $= m\angle$ _____ _____

$m\angle BAC + m\angle CAD + m\angle BAD =$ _____

$2m\angle$ _____ $+ 54^\circ = 360^\circ$ _____

$m\angle BAC =$ _____

$AB = AC$ _____

$m\angle$ _____ $= m\angle$ _____ _____

$2m\angle ABC + m\angle BAC =$ _____ _____

$m\angle ABC =$ _____

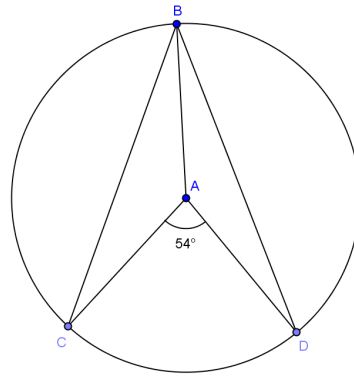

Chords of congruent arcs; BAC , BAD , angles inscribed in congruent arcs are congruent; 360° , circle; BAC ; 153° ; radii; ABC , ACB , base angles of isosceles; 180° , angles of triangle equal 180° ; 13.5°



Lesson 9: Arc Length and Areas of Sectors

Student Outcomes

- When students are provided with the angle measure of the arc and the length of the radius of the circle, they understand how to determine the length of an arc and the area of a sector.

Lesson Notes

This lesson explores the following geometric definitions:

ARC: An *arc* is any of the following three figures—a minor arc, a major arc, or a semicircle.

LENGTH OF AN ARC: The *length of an arc* is the circular distance around the arc.¹

MINOR AND MAJOR ARC: In a circle with center O , let A and B be different points that lie on the circle but are not the endpoints of a diameter. The *minor arc* between A and B is the set containing A , B , and all points of the circle that are in the interior of $\angle AOB$. The *major arc* is the set containing A , B , and all points of the circle that lie in the exterior of $\angle AOB$.

RADIAN: A *radian* is the measure of the central angle of a sector of a circle with arc length of one radius length.

SECTOR: Let arc \widehat{AB} be an arc of a circle with center O and radius r . The union of the segments \overline{OP} , where P is any point on the arc \widehat{AB} , is called a *sector*. The arc \widehat{AB} is called the arc of the sector, and r is called its radius.

SEMICIRCLE: In a circle, let A and B be the endpoints of a diameter. A *semicircle* is the set containing A , B , and all points of the circle that lie in a given half-plane of the line determined by the diameter.

Classwork

Opening (2 minutes)

- In Lesson 7, we studied arcs in the context of the degree measure of arcs and how those measures are determined.
- Today we examine the actual length of the arc, or arc length. Think of arc length in the following way: If we laid a piece of string along a given arc and then measured it against a ruler, this length would be the arc length.

¹ This definition uses the undefined term *distance around a circular arc* (**G-CO.A.1**). In grade 4, student might use wire or string to find the length of an arc.

Example 1 (12 minutes)

- Discuss the following exercise with a partner.

MP.1

Example 1

a. What is the length of the arc of degree measure 60° in a circle of radius 10 cm?

Arc length = $\frac{1}{6}(2\pi \times 10)$

Arc length = $\frac{10\pi}{3}$

The marked arc length is $\frac{10\pi}{3}$ cm.

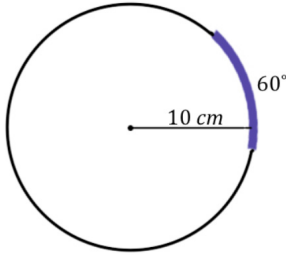

Scaffolding:

- Prompts to help struggling students along:
- If we can describe arc length as the length of the string that is laid along an arc, what is the length of string laid around the entire circle? (*The circumference, $2\pi r$*)
- What portion of the entire circle is the arc measure 60° ? ($\frac{60}{360} = \frac{1}{6}$; *the arc measure tells us that the arc length is $\frac{1}{6}$ of the length of the entire circle.*)

Encourage students to articulate why their computation works. Students should be able to describe that the arc length is a fraction of the entire circumference of the circle, and that fractional value is determined by the arc degree measure divided by 360° . This will help them generalize the formula for calculating the arc length of a circle with arc degree measure x° and radius r .

b. Given the concentric circles with center A and with $m\angle A = 60^\circ$, calculate the arc length intercepted by $\angle A$ on each circle. The inner circle has a radius of 10 and each circle has a radius 10 units greater than the previous circle.

Arc length of circle with radius $\overline{AB} = \left(\frac{60}{360}\right)(2\pi)(10) = \frac{10\pi}{3}$

Arc length of circle with radius $\overline{AC} = \left(\frac{60}{360}\right)(2\pi)(20) = \frac{20\pi}{3}$

Arc length of circle with radius $\overline{AD} = \left(\frac{60}{360}\right)(2\pi)(30) = \frac{30\pi}{3} = 10\pi$

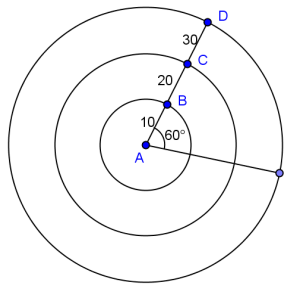

c. An arc, again of degree measure 60° , has an arc length of 5π cm. What is the radius of the circle on which the arc sits?

$$\frac{1}{6}(2\pi \times r) = 5\pi$$

$$2\pi r = 30\pi$$

$$r = 15$$

The radius of the circle on which the arc sits is 15 cm.

- Notice that provided any two of the following three pieces of information—the radius, the central angle (or arc degree measure), or the arc length—we can determine the third piece of information.

MP.8

d. Give a general formula for the length of an arc of degree measure x° on a circle of radius r .

$$\text{Arc length} = \left(\frac{x}{360}\right) 2\pi r$$

e. Is the length of an arc intercepted by an angle proportional to the radius? Explain.

Yes, the arc length is a constant $\frac{2\pi x}{360}$ times the radius when x is a constant angle measure, so it is proportional to the radius of an arc intercepted by an angle.

Support parts (a)–(d) with these follow up questions regarding arc lengths. Draw the corresponding figure with each question as you pose the question to the class.

- From the belief that for any number between 0 and 360, there is an angle of that measure, it follows that for any length between 0 and $2\pi r$, there is an arc of that length on a circle of radius r .
- Additionally, we drew a parallel with the 180° protractor axiom (“angles add”) in Lesson 7 with respect to arcs. For example, if we have arcs \widehat{AB} and \widehat{BC} as in the following figure, what can we conclude about $m\widehat{AC}$?

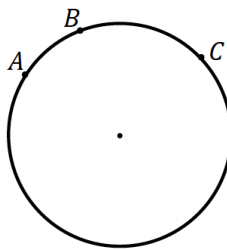

$$m\widehat{AC} = m\widehat{AB} + m\widehat{BC}$$

- We can draw the same parallel with arc lengths. With respect to the same figure, we can say:

$$\text{arc length}(\widehat{AC}) = \text{arc length}(\widehat{AB}) + \text{arc length}(\widehat{BC})$$

- Then, given any minor arc, such as minor arc \widehat{AB} , what must the sum of a minor arc and its corresponding major arc (in this example major arc \widehat{AXB}) sum to?
 - *The sum of their arc lengths is the entire circumference of the circle, or $2\pi r$.*
- What is the possible range of lengths of any arc length? Can an arc length have a length of 0? Why or why not?
 - *No, an arc has, by definition, two different endpoints. Hence, its arc length is always greater than zero.*
- Can an arc length have the length of the circumference, $2\pi r$?

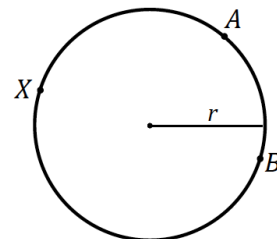

Students may disagree about this. Confirm that an arc length refers to a portion of a full circle. Therefore, arc lengths fall between 0 and $2\pi r$; $0 < \text{arc length} < 2\pi r$.

- In part (a), the arc length is $\frac{10\pi}{3}$. Look at part (b). Have students calculate the arc length as the central angle stays the same, but the radius of the circle changes. If students write out the calculations, they will see the relationship and constant of proportionality that we are trying to discover through the similarity of the circles.

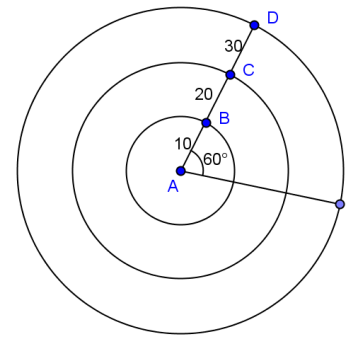
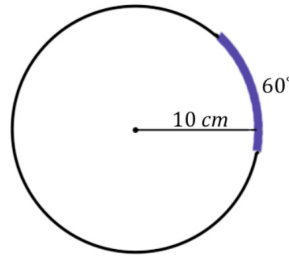

- What variable is determining arc length as the central angle remains constant? Why?
 - *The radius determines the size of the circle because all circles are similar.*
- Is the length of an arc intercepted by an angle proportional to the radius? If so, what is the constant of proportionality?
 - Yes, $\frac{2\pi x}{360}$ or $\frac{\pi x}{180}$, where x is a constant angle measure in degree, the constant of proportionality is $\frac{\pi}{180}$.
- What is the arc length if the central angle has a measure of 1° ?
 - $\frac{\pi}{180}$
- What we have just shown is that for every circle, regardless of the radius length, a central angle of 1° produces an arc of length $\frac{\pi}{180}$. Repeat that with me.
 - *For every circle, regardless of the radius length, a central angle of 1° produces an arc of length $\frac{\pi}{180}$.*
- Mathematicians have used this relationship to define a new angle measure, a radian. A radian is the measure of the central angle of a sector of a circle with arc length of one radius length. Say that with me.
 - *A radian is the measure of the central angle of a sector of a circle with arc length of one radius length.*
- So $1^\circ = \frac{\pi}{180}$ radians. What does 180° equal in radian measure?
 - π radians.
- What does 360° or a rotation through a full circle equal in radian measure?
 - 2π radians.
- Notice, this is consistent with what we found above.

Exercise 1 (5 minutes)

Exercise 1

The radius of the following circle is 36 cm, and the $m\angle ABC = 60^\circ$.

a. What is the arc length of \widehat{AC} ?

The degree measure of arc \widehat{AC} is 120° . Then the arc length of \widehat{AC} is

$$\text{Arc length} = \frac{1}{3}(2\pi \times 36)$$

$$\text{Arc length} = 24\pi$$

The arc length of \widehat{AC} is 24π cm.

b. What is the radian measure of the central angle?

Arc length = (angle measure of central angle in radians)(radius)

$$\text{Arc length} = (\text{angle measure of central angle in radians})(36)$$

$$\text{Arc length} = \left(\frac{\pi x}{180}\right)(36)$$

$$24\pi = 36(\text{angle measure of central angle in radians})$$

The measure of the central angle in radians = $\frac{24\pi}{36} = \frac{2\pi}{3}$ radians.

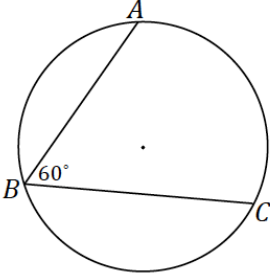

Discussion (5 minutes)

Discuss what a sector is and how to find the area of a sector.

- A sector can be thought of as the portion of a disk defined by an arc.

SECTOR: Let \widehat{AB} be an arc of a circle with center O and radius r . The union of all segments \overline{OP} , where P is any point of \widehat{AB} , is called a **sector**.

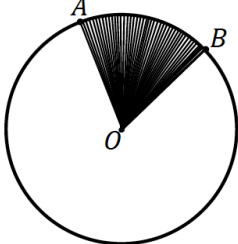

Example 2 (8 minutes)

Allow students to work in partners or small groups on the questions before offering prompts.

Scaffolding:

We calculated arc length by determining the portion of the circumference the arc spanned. How can we use this idea to find the area of a sector in terms of area of the entire disk?

Example 2

- a. Circle O has a radius of 10 cm. What is the area of the circle? Write the formula.

$$\text{Area} = (\pi(10 \text{ cm})^2) = 100\pi \text{ cm}^2$$

- b. What is the area of half of the circle? Write and explain the formula.

$$\text{Area} = \frac{1}{2}(\pi(10 \text{ cm})^2) = 50\pi \text{ cm}^2. \text{ 10 is the radius of the circle, and } \frac{1}{2} = \frac{180}{360} \text{ which is the fraction of the circle.}$$

- c. What is the area of a quarter of the circle? Write and explain the formula.

$$\text{Area} = \frac{1}{4}(\pi(10 \text{ cm})^2) = 25\pi \text{ cm}^2. \text{ 10 is the radius of the circle, and } \frac{1}{4} = \frac{90}{360} \text{ which is the fraction of the circle.}$$

- d. Make a conjecture about how to determine the area of a sector defined by an arc measuring 60 degrees.

$$\text{Area}(\text{sector } AOB) = \frac{60}{360}(\pi(10)^2) = \frac{1}{6}(\pi(10)^2); \text{ the area of the circle times the arc measure divided by 360}$$

$$\text{Area}(\text{sector } AOB) = \frac{50\pi}{3}$$

$$\text{The area of the sector } AOB \text{ is } \frac{50\pi}{3} \text{ cm}^2.$$

MP.7

Again, as with Example 1, part (a), encourage students to articulate why the computation works.

- e. Circle O has a minor arc \widehat{AB} with an angle measure of 60° . Sector AOB has an area of 24π . What is the radius of circle O ?

$$24\pi = \frac{1}{6}(\pi(r)^2)$$

$$144\pi = (\pi(r)^2)$$

$$r = 12$$

The radius has a length of 12 units.

- f. Give a general formula for the area of a sector defined by arc of angle measure x° on a circle of radius r ?

$$\text{Area of sector} = \left(\frac{x}{360}\right)\pi r^2$$

Exercises 2–3 (7 minutes)

Exercises 2–3

2. The area of sector AOB in the following image is 28π . Find the measurement of the central angle labeled x° .

$$28\pi = \frac{x}{360} (\pi(12)^2)$$

$$x = 70$$

The central angle has a measurement of 70° .

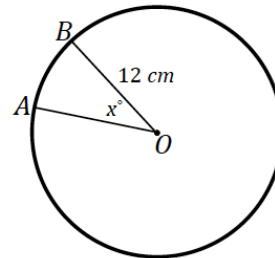

3. In the following figure, circle O has a radius of 8 cm, $m\angle AOC = 108^\circ$ and $\widehat{AB} = \widehat{AC} = 10$ cm. Find:

- a. $\angle OAB$

$$36^\circ$$

- b. \widehat{BC}

$$144^\circ$$

- c. Area of sector BOC

$$\text{Area}(\text{sector } BOC) = \frac{144}{360} (\pi(8)^2)$$

$$\text{Area}(\text{sector } BOC) \approx 80.4$$

The area of sector BOC is 80.4 cm^2 .

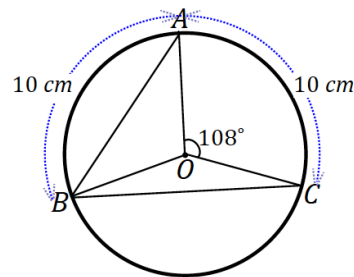

Closing (1 minute)

Present the following questions to the entire class, and have a discussion.

- What is the formula to find the arc length of a circle provided the radius r and an arc of angle measure x° ?
 - $\text{Arc length} = \left(\frac{x}{360}\right) (2\pi r)$
- What is the formula to find the area of a sector of a circle provided the radius r and an arc of angle measure x° ?
 - $\text{Area of sector} = \left(\frac{x}{360}\right) (\pi r^2)$
- What is a radian?
 - The measure of the central angle of a sector of a circle with arc length of one radius length.

Lesson Summary

Relevant Vocabulary

- **ARC:** An *arc* is any of the following three figures—a minor arc, a major arc, or a semicircle.
- **LENGTH OF AN ARC:** The *length of an arc* is the circular distance around the arc.¹
- **MINOR AND MAJOR ARC:** In a circle with center O , let A and B be different points that lie on the circle but are not the endpoints of a diameter. The *minor arc* between A and B is the set containing A , B , and all points of the circle that are in the interior of $\angle AOB$. The *major arc* is the set containing A , B , and all points of the circle that lie in the exterior of $\angle AOB$.
- **RADIAN:** A *radian* is the measure of the central angle of a sector of a circle with arc length of one radius length.
- **SECTOR:** Let arc \widehat{AB} be an arc of a circle with center O and radius r . The union of the segments \overline{OP} , where P is any point on the arc \widehat{AB} , is called a *sector*. The arc \widehat{AB} is called the arc of the sector, and r is called its radius.
- **SEMICIRCLE:** In a circle, let A and B be the endpoints of a diameter. A *semicircle* is the set containing A , B , and all points of the circle that lie in a given half-plane of the line determined by the diameter.

Exit Ticket (5 minutes)

Name _____

Date _____

Lesson 9: Arc Length and Areas of Sectors

Exit Ticket

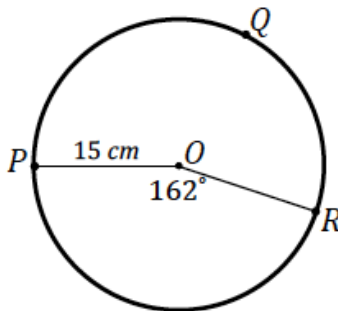

1. Find the arc length of \widehat{PQR} .

2. Find the area of sector POR .

Exit Ticket Sample Solutions

1. Find the arc length of \widehat{PQR} .

$$\text{Arc length}(\widehat{PR}) = \frac{162}{360}(2\pi \times 15)$$

$$\text{Arc length}(\widehat{PR}) = 13.5\pi$$

$$\text{Circumference}(\text{circle } O) = 30\pi$$

The arc length of \widehat{PQR} is $(30\pi - 13.5\pi)$ cm or 16.5π cm.

2. Find the area of sector POR .

$$\text{Area}(\text{sector } POR) = \frac{162}{360}(\pi(15)^2)$$

$$\text{Area}(\text{sector } POR) = 101.25\pi$$

The area of sector POR is 101.25π cm².

Problem Set Sample Solutions

1. P and Q are points on the circle of radius 5 cm and the measure of arc \widehat{PQ} is 72° . Find, to one decimal place each of the following:

a. The length of arc \widehat{PQ}

$$\text{Arc length}(\widehat{PQ}) = \frac{72}{360}(2\pi \times 5)$$

$$\text{Arc length}(\widehat{PQ}) = 2\pi$$

The arc length of \widehat{PQ} is 2π cm or approximately 6.3 cm.

b. Find the ratio of the arc length to the radius of the circle.

$$\frac{\pi}{180} \cdot 72 = \frac{2\pi}{5} \text{ radians}$$

- c. The length of chord PQ

The length of PQ is twice the value of x in $\triangle OQR$.

$$x = 5 \sin 36$$

$$PQ = 2x = 10 \sin 36$$

Chord PQ has a length of $10 \sin 36$ cm or approximately 5.9 cm.

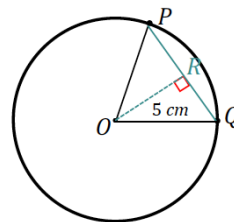

- d. The distance of the chord PQ from the center of the circle.

The distance of chord PQ from the center of the circle is labeled as y in $\triangle OQR$.

$$y = 5 \cos 36$$

The distance of chord PQ from the center of the circle is $5 \cos 36$ cm or approximately 4 cm.

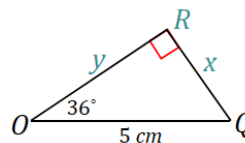

- e. The perimeter of sector POQ .

$$Perimeter(\text{sector}) = 5 + 5 + 2\pi$$

$$Perimeter(\text{sector}) = 10 + 2\pi$$

The perimeter of sector POQ is $(10 + 2\pi)$ cm or approximately 16.3 cm.

- f. The area of the wedge between the chord PQ and the arc \widehat{PQ}

$$Area(\text{wedge}) = Area(\text{sector}) - Area(\triangle POQ)$$

$$Area(\triangle POQ) = \frac{1}{2}(10 \sin 36)(5 \cos 36)$$

$$Area(\text{sector } POR) = \frac{72}{360}(\pi(5)^2)$$

$$Area(\text{wedge}) = \frac{72}{360}(\pi(5)^2) - \frac{1}{2}(10 \sin 36)(5 \cos 36)$$

The area of sector POQ is approximately 3.8 cm^2 .

- g. The perimeter of this wedge

$$Perimeter(\text{wedge}) = 2\pi + 10 \sin 36$$

The perimeter of the wedge is approximately 12.2 cm.

2. What is the radius of a circle if the length of a 45° arc is 9π ?

$$9\pi = \frac{45}{360}(2\pi r)$$

$$r = 36$$

The radius of the circle is 36 units.

3. Arcs \widehat{AB} and \widehat{CD} both have an angle measure of 30° , but their arc lengths are not the same. $OB = 4$ and $OD = 6$.

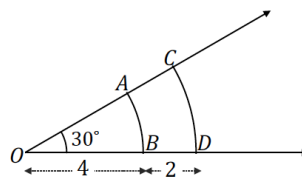

a. What are the arc lengths of arcs \widehat{AB} and \widehat{CD} ?

$$\text{Arc length}(\widehat{AB}) = \frac{30}{360}(2\pi \times 4)$$

$$\text{Arc length}(\widehat{AB}) = \frac{2}{3}\pi$$

The arc length of \widehat{AB} is $\frac{2}{3}\pi$ units.

$$\text{Arc length}(\widehat{CD}) = \frac{30}{360}(2\pi \times 6)$$

$$\text{Arc length}(\widehat{CD}) = \pi$$

The arc length of \widehat{CD} is π units.

b. What is the ratio of the arc length to the radius for all of these arcs? Explain.

$$\frac{30\pi}{180} = \frac{\pi}{6} \text{ radians, the angle is constant, so the ratio of arc length to radius will be the angle measure, } 30^\circ \times \frac{\pi}{180}.$$

c. What are the areas of the sectors AOB and COD ?

$$\text{Area}(\text{sector } AOB) = \frac{30}{360}(\pi(4)^2)$$

$$\text{Area}(\text{sector } AOB) = \frac{4}{3}\pi$$

The area of the sector AOB is $\frac{4}{3}\pi$ units².

$$\text{Area}(\text{sector } COD) = \frac{30}{360}(\pi(6)^2)$$

The area of the sector AOB is 3π units².

4. In the circles shown, find the value of x .

The circles shown have central angles that are equal in measure.

a.

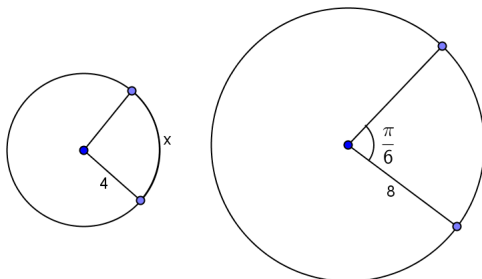

$$x = \frac{2\pi}{3} \text{ radians}$$

b.

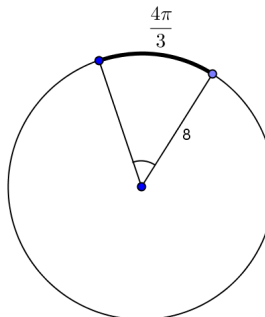

$$x = 30$$

c.

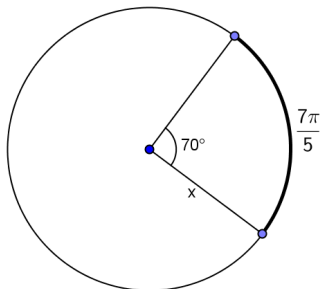

$$x = \frac{18}{5}$$

d.

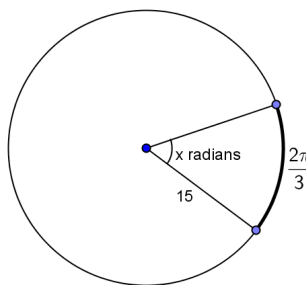

$$x = \frac{2\pi}{45}$$

5. The concentric circles all have center A. The measure of the central angle is 45°. The arc lengths are given.

a. Find the radius of each circle.

$$\text{Radius of inner circle: } \frac{\pi}{2} = \frac{45\pi}{180}r, r = 2$$

$$\text{Radius of middle circle: } \frac{5\pi}{4} = \frac{45\pi}{180}r, r = 5$$

$$\text{Radius of outer circle: } \frac{9\pi}{4} = \frac{45\pi}{180}r, r = 9$$

b. Determine the ratio of the arc length to the radius of each circle, and interpret its meaning.

$\frac{\pi}{4}$ is the ratio of the arc length to the radius of each circle. It is the measure of the central angle in radians.

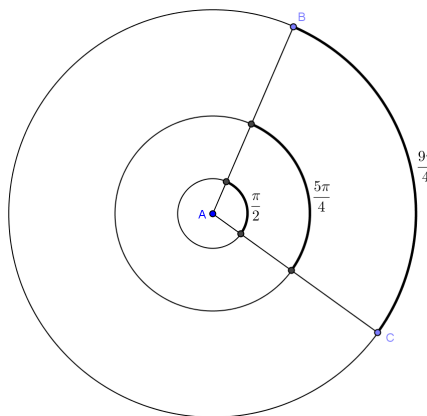

6. In the figure, if $\widehat{PQ} = 10$ cm, find the length of arc \widehat{QR} ?

Since 6° is $\frac{1}{15}$ of 90° , then the arc length of \widehat{QR} is $\frac{1}{15}$ of 10 cm; the arc length of \widehat{QR} is $\frac{2}{3}$ cm.

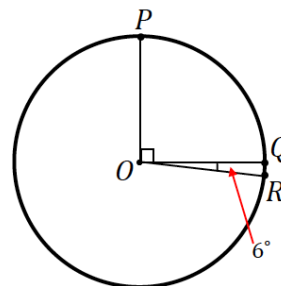

7. Find, to one decimal place, the areas of the shaded regions.

a.

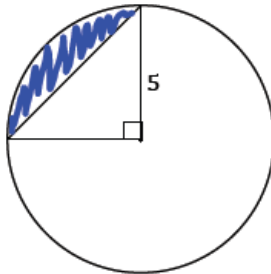

Shaded Area = Area of sector – Area of Triangle (or $\frac{3}{4}$ (Area of circle) + Area of triangle)

$$\text{Shaded Area} = \frac{90}{360}(\pi(5)^2) - \frac{1}{2}(5)(5)$$

$$\text{Shaded Area} = 6.25\pi - 12.5$$

The shaded area is approximately 1.13 unit².

b. The following circle has a radius of 2.

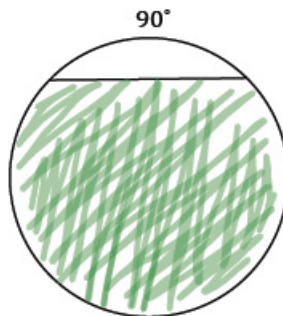

$$\text{Shaded Area} = \frac{3}{4}(\text{Area of circle}) + \text{Area of triangle}$$

Note: The triangle is a 45° – 45° – 90° triangle with legs of length 2 (the legs are comprised by the radii, like the triangle in the previous question).

$$\text{Shaded Area} = \frac{3}{4}(\pi(2)^2) + \frac{1}{2}(2)(2)$$

$$\text{Shaded Area} = 3\pi + 2$$

The shaded area is approximately 1.4 units².

c.

Shaded Area = (Area of 2 sectors) + (Area of 2 triangles)

$$\text{Shaded Area} = 2 \left(\frac{98}{3} \pi \right) + 4 \left(\frac{49\sqrt{3}}{2} \right)$$

$$\text{Shaded Area} = \frac{196}{3} \pi + 98\sqrt{3}$$

The shaded area is approximately 74.99 units².



Lesson 10: Unknown Length and Area Problems

Student Outcomes

- Students apply their understanding of *arc length* and *area of sectors* to solve problems of unknown area and length.

Lesson Notes

This lesson continues the work started in Lesson 9 as students solve problems on arc length and area of sectors. The lesson is intended to be 45 minutes of problem solving with a partner. Problems vary in level of difficulty and can be assigned specifically based on student understanding. The problem set can be used in class for some students or assigned as homework. Students who need to focus on a small number of problems could finish the other problems at home. Teachers may choose to model two or three problems with the entire class.

Exercise 4 is a modeling problem highlighting **G-MG.A.1** and MP.4.

Classwork

Begin with a quick whole class discussion of an annulus. Project the figure on the right on the board.

Opening Exercise (3 minutes)

Opening Exercise

In the following figure, a cylinder is carved out from within another cylinder of the same height; the bases of both cylinders share the same center.

- Sketch a cross section of the figure parallel to the base.

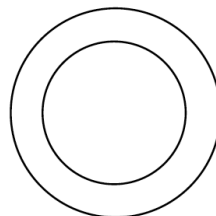
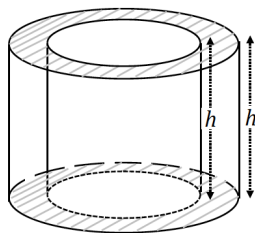

Scaffolding:

- Post area of sector and arc length formulas for easy reference.
- A review of compound figures may be required before this lesson.
- Scaffold the task by asking students to compute the area of the circle with radius r , then the circle with radius s , and then ask how the shaded region is related to the two circles.
- Use an example with numerical values for s and r on the coordinate plane, and ask students to estimate the area first (see example below).

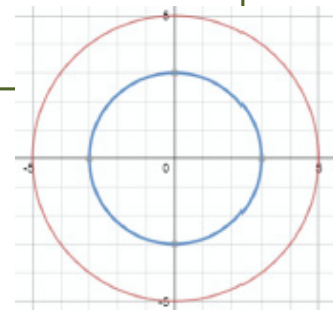

Confirm that students' sketch is correct before allowing them to proceed to part (b).

MP.2
&
MP.7

- b. Mark and label the shorter of the two radii as r and the longer of the two radii s . Show how to calculate the area of the shaded region and explain the parts of the expression.

$$\text{Area}(\text{shaded}) = \pi(s^2 - r^2)$$

s = radius of outer circle

r = radius of inner circle

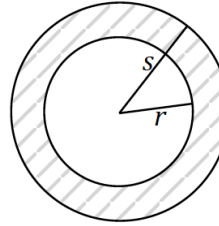

The figure you sketched in part (b) is called an *annulus*; it is a ring shaped region or the region lying between two concentric circles. In Latin, annulus means “little ring.”

Exercises (35 minutes)

1. Find the area of the following annulus.

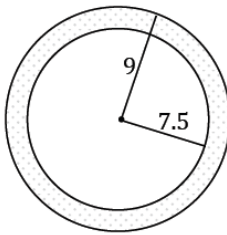

$$\text{Area}(\text{shaded}) = \pi(9^2 - 7.5^2)$$

$$\text{Area}(\text{shaded}) = 24.75\pi$$

The area of the annulus is 24.75π units².

2. The larger circle of an annulus has a diameter of 10 cm, and the smaller circle has a diameter of 7.6 cm. What is the area of the annulus?

The radius of the larger circle is 5 cm, and the radius of the smaller circle is 3.8 cm.

$$\text{Area}(\text{shaded}) = \pi(5^2 - 3.8^2)$$

$$\text{Area}(\text{shaded}) = 10.56\pi$$

The area of the annulus is 10.56π cm².

3. In the following annulus, the radius of the larger circle is twice the radius of the smaller circle. If the area of the following annulus is 12π units², what is the radius of the larger circle?

$\text{Area}(\text{shaded})$:

$$\pi((2r)^2 - r^2) = 12\pi$$

$$3r^2 = 12$$

$$r = 2$$

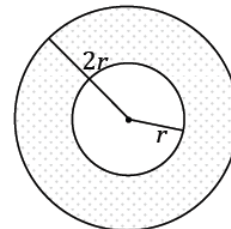

The radius of the larger circle is twice the radius of the smaller circle or $2(2) = 4$; the radius of the larger circle is 4 units.

MP.4

4. An ice cream shop wants to design a super straw to serve with their extra thick milkshakes that is double the width and thickness of a standard straw. A standard straw is 8 mm in diameter and 0.5 mm thick.
- What is the cross-sectional (parallel to the base) area of the new straw (round to the nearest hundredth)?
47.12 mm²
 - If the new straw is 23 mm long, what is the maximum volume of milkshake that can be in the straw at one time (round to the nearest hundredth)?
3,540.57 mm³
 - A large milkshake is 32 ounces (approximately 950 mL). If Corbin withdraws the full capacity of a straw 10 times a minute, what is the minimum amount of time that it will take him to drink the milkshake (round to the nearest minute)?
27 minutes

5. In the circle given, \overline{ED} is the diameter and is perpendicular to chord \overline{CB} . $DF = 8$ cm and $FE = 2$ cm. Find AC , BC , $m\angle CAB$, the arc length of \widehat{CEB} , and the area of sector \widehat{CEB} (round to the nearest hundredth, if necessary).
AC = 5 cm, BC = 8 cm, $m\angle CAB = 2(53.13) = 106.26^\circ$, arc length = 9.27 cm, area = 23.18 cm²

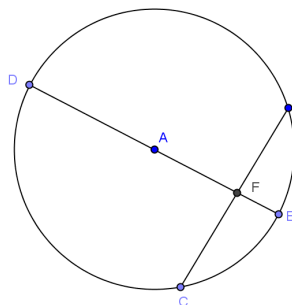

6. Given circle A with $\angle BAC \cong \angle BAD$, find the following (round to the nearest hundredth, if necessary):
- $m\widehat{CD}$
45°
 - $m\widehat{CBD}$
315°
 - $m\widehat{BCD}$
202.5°
 - Arc length \widehat{CD}
9.42 yds
 - Arc length \widehat{CBD}
65.97 yds

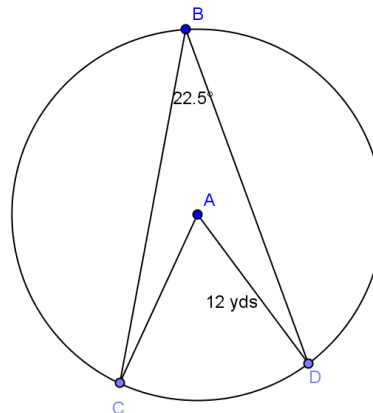

- f. Arc length \widehat{BCD}
42.41 yds
- g. Area of sector \widehat{CD}
56.55 yds²
- h. Area of sector \widehat{CBD}
395.84 yds²
- i. Area of sector \widehat{BCD}
254.47 yds²

7. Given circle A , find the following (round to the nearest hundredth, if necessary):

- a. Circumference of circle A
96 yds
- b. Radius of circle A
15.28 yds
- c. Area of sector \widehat{CD}
91.69 yds²

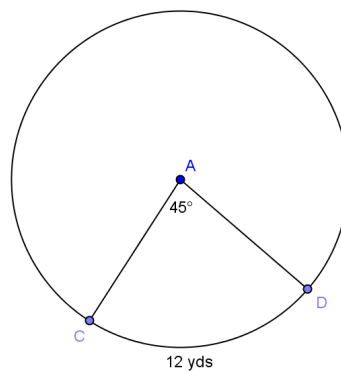

8. Given circle A , find the following (round to the nearest hundredth, if necessary):

- a. $m\angle CAD$
47.74°
- b. Area of sector \widehat{CD}
60

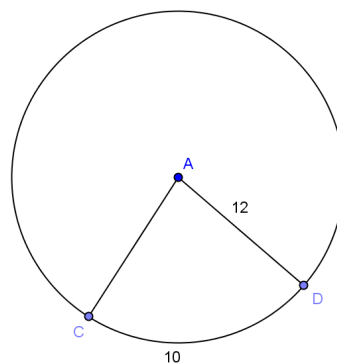

9. Find the area of the shaded region (round to the nearest hundredth).

35.73

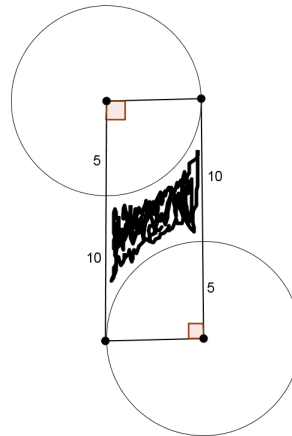

10. Many large cities are building or have built mega Ferris wheels. One is 600 feet in diameter and has 48 cars each seating up to 20 people. Each time the Ferris wheel turns θ degrees, a car is in a position to load.

a. How far does a car move with each rotation of θ degrees (round to the nearest whole number)?

39 feet

b. What is the value of θ in degrees?

7.50°

11. $\triangle ABC$ is an equilateral triangle with edge length 20 cm. D , E , and F are midpoints of the sides. The vertices of the triangle are the centers of the circles creating the arcs shown. Find the following (round to the nearest hundredth):

a. The area of the sector with center A .

52.36 cm^2

b. The area of triangle ABC .

173.21 cm^2

c. The area of the shaded region.

16.13 cm^2

d. The perimeter of the shaded region.

31.42 cm

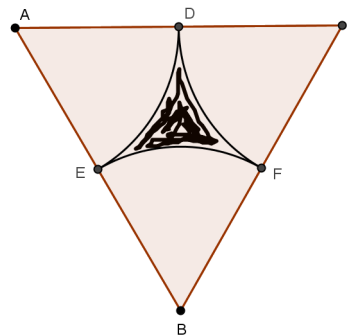

12. In the figure shown, $AC = BF = 5$ cm, $GH = 2$ cm, and $m\angle HBI = 30^\circ$. Find the area in the rectangle, but outside of the circles (round to the nearest hundredth).

13.72 cm²

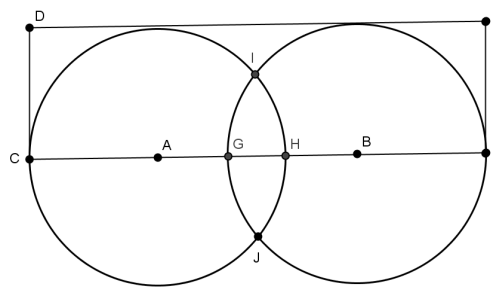

13. This is a picture of a piece of a mosaic tile. If the radius of each smaller circle is 1 inch, find the area of red section, the white section, and the blue section (round to the nearest hundredth).

Red = 2.28 in², White = 10.28 in², Blue = 2.28 in²

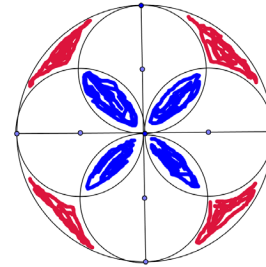

Closing (2 minutes)

Present the questions to the class, and have a discussion, or have students answer individually in writing. Use this as a method of informal assessment.

- Explain how to find the area of a sector of a circle if you know the measure of the arc in degrees.
 - Find the fraction of the circumference by dividing the measure of the arc in degrees by 360, and then multiply by the circumference $2\pi r$.
- Explain how to find the arc length of an arc if you know the central angle.
 - Find the fraction of the area by dividing the measure of the central angle in degrees by 360, then multiply by the circumference πr^2 .

Exit Ticket (5 minutes)

Name _____

Date _____

Lesson 10: Unknown Length and Area Problems

Exit Ticket

1. Given circle A , find the following (round to the nearest hundredth):

a. The $m\widehat{BC}$ in degrees.

b. The area of sector \widehat{BC} .

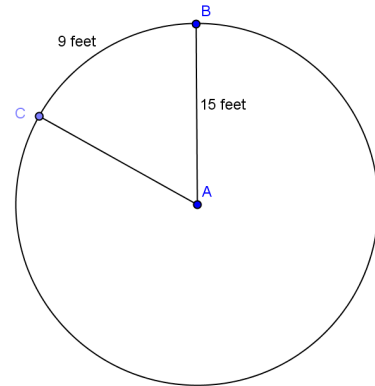

2. Find the shaded area (round to the nearest hundredth).

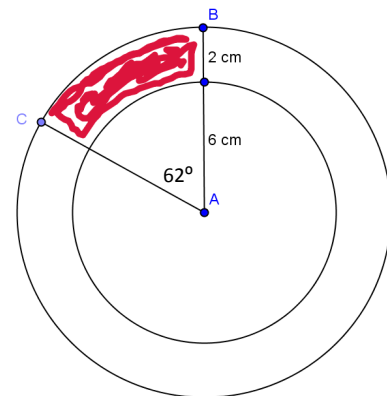

Exit Ticket Sample Solutions

1. Given circle A , find the following (round to the nearest hundredth):

- The $m\widehat{BC}$ in degrees.
68.75°
- The area of sector \widehat{BC} .
135 ft²

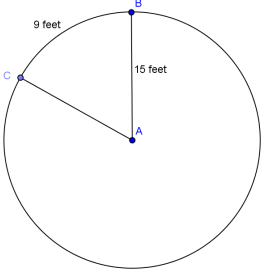

2. Find the shaded area.
15.15 cm²

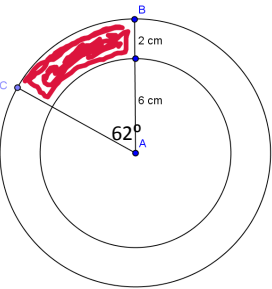

Problem Set Sample Solutions

Students should continue the work they began in class for homework.

1. Find the area of the shaded region if the diameter is 32 inches (round to the nearest hundredth).
214.47 in²

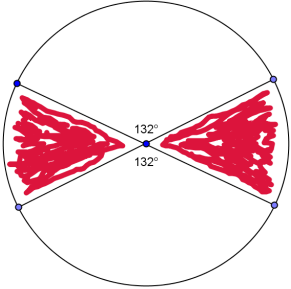

2. Find the area of the entire circle given the area of the sector.
500 in²

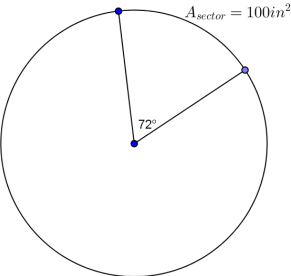

3. \widehat{DF} and \widehat{BG} are arcs of concentric circles with \overline{BD} and \overline{FG} lying on the radii of the larger circle. Find the area of the region (round to the nearest hundredth).

108.00 cm^2

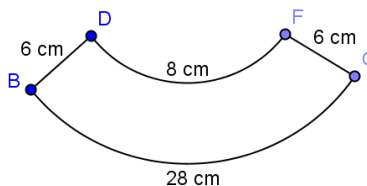

4. Find the radius of the circle, x , y , and z (round to the nearest hundredth).

Radius = 7.64 cm, $x = 74.99^\circ$, $y = 134.99^\circ$, $z = 16$ cm

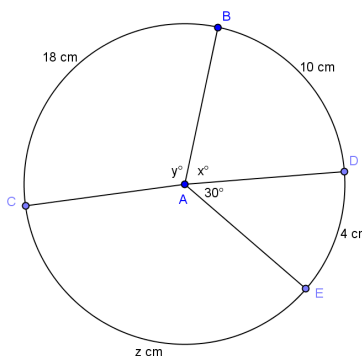

5. In the figure, the radii of two concentric circles are 24 cm and 12 cm. $m\widehat{DAE} = 120^\circ$. If a chord \overline{DE} of the larger circle intersects the smaller circle only at C , find the area of the shaded region in terms of π .

288 π cm^2

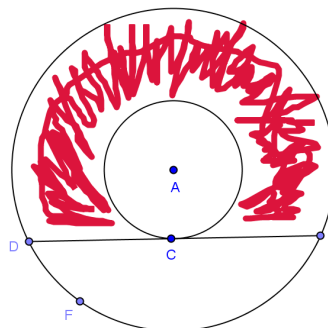

2. A five-pointed star with vertices $A, M, B, N,$ and C is inscribed in a circle as shown. Chords \overline{AB} and \overline{MC} intersect at point P .

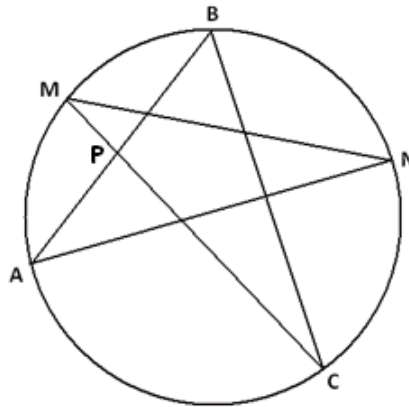

- a. What is the value of $m\angle BAN + m\angle NMC + m\angle CBA + m\angle ANM + m\angle MCB$, the sum of the measures of the angles in the points of the star? Explain your answer.
- b. Suppose M is the midpoint of the arc AB , N is the midpoint of arc BC , and $m\angle BAN = \frac{1}{2}m\angle CBA$. What is $m\angle BPC$, and why?

3. Two chords, \overline{AC} and \overline{BD} in a circle with center O , intersect at right angles at point P . AB equals the radius of the circle.

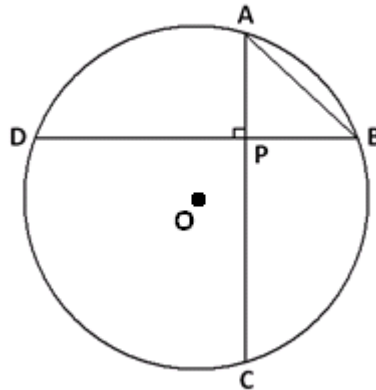

- a. What is the measure of the arc AB ?
- b. What is the value of the ratio $\frac{DC}{AB}$? Explain how you arrived at your answer.

- 4.
- a. An arc of a circle has length equal to the diameter of the circle. What is the measure of that arc in radian? Explain your answer.

- b. Two circles have a common center O . Two rays from O intercept the circles at points A , B , C , and D as shown.

Suppose $OA : OB = 2 : 5$ and that the area of the sector given by A , O , and D is 10 cm^2 .

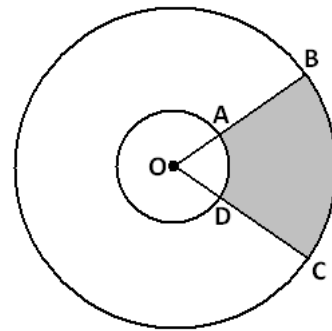

- i. What is the ratio of the measure of the arc AD to the measure of the arc BC ?
- ii. What is the area of the shaded region given by the points A , B , C , and D ?
- iii. What is the ratio of the length of the arc AD to the length of the arc BC ?

5. In this diagram, the points P , Q , and R are collinear and are the centers of three congruent circles. Q is the point of contact of two circles that are externally tangent. The remaining points at which two circles intersect are labeled A , B , C , and D , as shown.

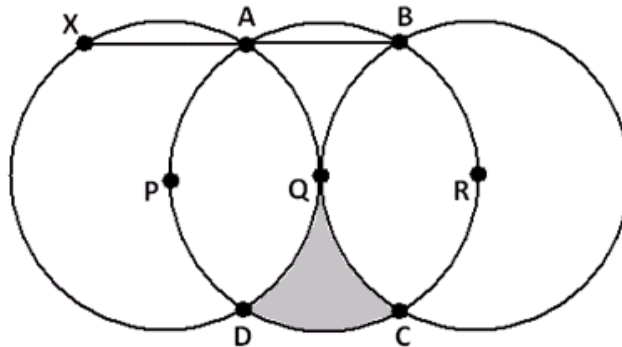

- a. Segment \overline{AB} is extended until it meets the circle with center P at a point X . Explain, in detail, why X , P , and D are collinear.
- b. In the diagram, a section is shaded. What percent of the full area of the circle with center Q is shaded?

A Progression Toward Mastery

Assessment Task Item		STEP 1 Missing or incorrect answer and little evidence of reasoning or application of mathematics to solve the problem.	STEP 2 Missing or incorrect answer but evidence of some reasoning or application of mathematics to solve the problem.	STEP 3 A correct answer with some evidence of reasoning or application of mathematics to solve the problem, <u>or</u> an incorrect answer with substantial evidence of solid reasoning or application of mathematics to solve the problem.	STEP 4 A correct answer supported by substantial evidence of solid reasoning or application of mathematics to solve the problem.
1	a G-C.A.1 G-C.A.2	Student does not describe an accurate construction procedure.	Student describes an accurate construction procedure but does not fully justify its validity.	Student accurately describes the construction procedure and justifies its validity but with a few minor errors.	Student accurately describes the construction procedure and correctly justifies its validity.
	b G-C.A.1 G-C.A.2	Student does not attempt to find the distance of the side from the center.	Student makes some progress towards finding the distance, but is using the wrong side.	Student attempts to find the distance of the correct side, but makes a minor mathematical error leading to an incorrect answer.	Student finds the correct distance of the side to the radius with supporting work.
	c G-C.A.1 G-C.A.2	Student does not draw an inscribed circle or calculate the area.	Student draws an inscribed circle, but does not calculate the area or calculates that area showing no evidence of understanding.	Student draws an inscribed circle and attempts to calculate the area, but makes a minor mathematical error leading to an incorrect answer.	Student accurately draws an inscribed circle and calculates the area.
2	a G-C.A.2	Student is unable to find a relevant geometric result that aids in answering the question.	Student makes some progress applying the inscribed angle theorem and answering the question.	Student makes correct use of the inscribed angle results to answer the question, but justification is not fully explained.	Student makes correct use of the inscribed angle results to fully answer the question with clear justifications.
	b G-C.A.2	Student is unable to find a relevant geometric result that aids in answering the question.	Student makes some progress applying the inscribed angle theorem and answering the question.	Student makes correct use of the inscribed angle results to answer the question, but justification is not fully	Student makes correct use of the inscribed angle results to fully answer the question with clear justifications.

				explained.	
3	a G-C.A.2	Student does not identify relevant central angle to the problem and makes little progress towards finding the solution.	Student makes some progress identifying the relevant central angle for the problem and there is evidence of some steps towards finding the solution.	Student provides correct solution but does not give complete details as to how the solution was obtained.	Student provides correct solution and gives a complete, detailed explanation of how the solution was obtained.
	b G-C.A.2	Student does not identify relevant central angle to the problem and makes little progress towards finding the solution.	Student makes some progress identifying the relevant central angle and inscribed angles needed for the problem and there is evidence of some steps towards finding the solution.	Student provides correct solution but does not give complete details as to how the solution was obtained.	Student provides correct solution and gives a complete, detailed explanation of how the solution was obtained.
4	a G-C.B.5	Student does not connect one radius of the circle to one radian of turning.	Student exhibits some understanding of the relationship between one radius and one radian and makes some progress in providing an answer.	Student provides correct solution but does not give complete details as to how the solution was obtained.	Student provides correct solution and gives a complete, detailed explanation of how the solution was obtained.
	b (i) G-C.B.5	Student does not distinguish between arc measure and arc length and does not make use of the arc length/radius proportionality.	Student exhibits some understanding of the arc measure, arc length, and radius relationships and makes some progress in providing the answer.	Student exhibits some clear understanding of the arc measure, arc length, and radius relationships and makes good progress in providing an answer, but with a minor mathematical mistake.	Student provides a correct answer with accurate supporting work.
	b (ii) G-C.B.5	Student shows no knowledge of calculating the area of a sector.	Student shows some knowledge of finding the area of a sector, but does not calculate the area of either sector correctly.	Student calculates the area of each sector correctly, but does not calculate the area of the shaded region.	Student calculates the area of the shaded region correctly.
	b (iii) G-C.B.5	Student does not distinguish between arc measure and arc length and does not make use of the arc length/radius proportionality.	Student exhibits some understanding of the arc measure, arc length, and radius relationships and makes some progress in providing the answer.	Student exhibits some clear understanding of the arc measure, arc length, and radius relationships and makes good progress in providing the answer, but with a minor mathematical mistake.	Student provides a correct answer with accurate supporting work.

5	a G-C.A.2 G-C.A.3 G-C.B.5	Student does not articulate a clear and correct explanation.	Student makes some attempt to provide a clear explanation but with major mathematical mistakes.	Student provides a clear explanation, but with minor mathematical mistakes.	Student gives complete and thorough explanation.
	b G-C.A.2 G-C.A.3 G-C.B.5	Student does not develop a plan for computing the desired area.	Student makes some movement towards computing the desired area.	Student develops a correct plan for computing the desired area, but makes minor mathematical mistakes.	Student develops a correct plan and computes the desired area correctly.

Name _____

Date _____

1. Consider a right triangle drawn on a page with sides of lengths 3 cm, 4 cm, and 5 cm.

- a. Describe a sequence of straightedge and compass constructions that allow you to draw the circle that circumscribes the triangle. Explain why your construction steps successfully accomplish this task.

Label the vertices of the right triangle A , B , and C as shown. Because $\angle ABC$ is a right angle, \overline{AC} will be the diameter of the circle. So, the midpoint of \overline{AC} is the center. We first need to construct that midpoint.

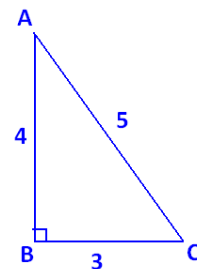

1. Set a compass at point A with its width equal to AC . Draw a circle.
2. Set the compass at point C with the same width AC . Draw a circle.
3. Connect the two points of intersection of these circles with a line segment. This line segment intersects \overline{AC} at its midpoint. Call it M .
4. Set the compass at point M with width MA . Draw the circle. This is the circumscribing circle for the triangle.

(Note that we could also locate the center of the circumscribing circle by constructing the perpendicular bisectors of any two sides of the triangle. Their point of intersection is the center.)

- b. What is the distance of the side of the right triangle of length 3 cm from the center of the circle that circumscribes the triangle?

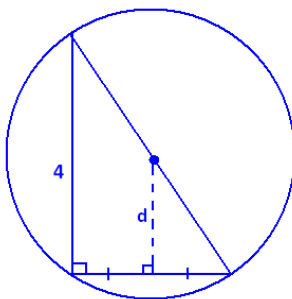

The distance, d , we seek is the length of the line segment connecting the center of the circumscribing circle to the midpoint of the side of the triangle of length 3. This segment is perpendicular to that side. Thus, we see two similar right triangles with scale factor 2. It follows that $d = \frac{1}{2} \cdot 4 \text{ cm} = 2 \text{ cm}$.

- c. What is the area of the inscribed circle for the triangle?

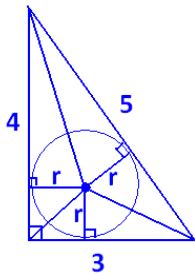

Draw in three radii for the inscribed circle, as shown. They meet the sides of the triangle at right angles. Each radius can be thought of as the height of a small triangle within the larger 3-4-5 triangle. If the radius of the inscribed circle is r , then the area of the whole 3-4-5 triangle is $(\frac{1}{2} \cdot 3 \cdot r) + (\frac{1}{2} \cdot 4 \cdot r) + (\frac{1}{2} \cdot 5 \cdot r) = 6r$.

However, the area of the triangle is $\frac{1}{2} \cdot 3 \cdot 4 = 6$; so, $r = 1$ cm, and the area of the inscribed circle is $\pi 1^2 = \pi \text{ cm}^2$.

2. A five-pointed star with vertices $A, M, B, N,$ and C is inscribed in a circle as shown. Chords \overline{AB} and \overline{MC} intersect at point P .

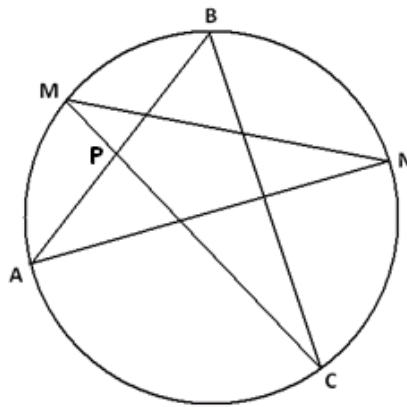

- a. What is the value of $m\angle BAN + m\angle NMC + m\angle CBA + m\angle ANM + m\angle MCB$, the sum of the measures of the angles in the points of the star? Explain your answer.

The measure of $\angle BAN$ is half the measure of the arc \widehat{BN} ; the same is true for the four remaining angles. Thus, the sum of all five angle measures is half the sum of the measures of ALL the arcs in the circle.

The sum of angle measures is $\frac{1}{2} \cdot 360^\circ = 180^\circ$.

- b. Suppose M is the midpoint of the arc AB , N is the midpoint of arc BC , and $m\angle BAN = \frac{1}{2}m\angle CBA$. What is $m\angle BPC$, and why?

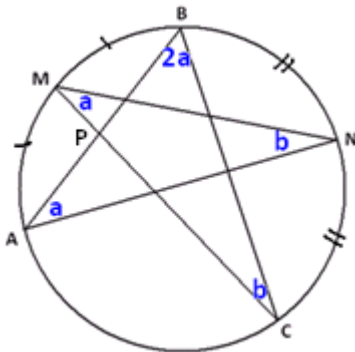

The angles marked a are congruent because they are inscribed angles from congruent arcs. This is similar for the angles marked b . We are also told that $m\angle CBA$ is double $m\angle BAN$.

From part (a), we have $4a + 2b = 180^\circ$; so, $2a + b = 90^\circ$.

Using the fact that angles in $\triangle BPC$ add to 180° , we get

$$m\angle BPC = 180^\circ - 2a - b = 90^\circ.$$

3. Two chords, \overline{AC} and \overline{BD} in a circle with center O , intersect at right angles at point P . AB equals the radius of the circle.

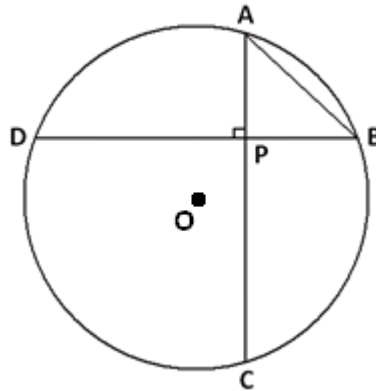

- a. What is the measure of the arc AB ?

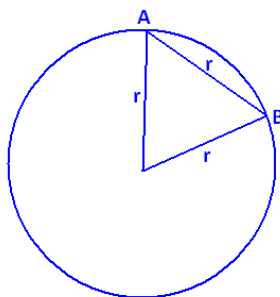

Draw in the central angle to chord \overline{AB} . We see an equilateral triangle. The central angle, and hence arc AB , has measure 60° .

- b. What is the value of the ratio $\frac{DC}{AB}$? Explain how you arrived at your answer.

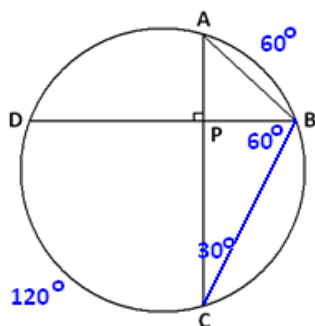

Draw chord \overline{BC} . By the inscribed/central angle theorem, $m\angle ACB = 30^\circ$. In $\triangle PBC$, it then follows that $m\angle PBC = 60^\circ$; so, arc DC has a measure of 120° . Draw this central angle.

Draw the line segment \overline{OX} perpendicular to \overline{DC} , as shown. We see that $\triangle DXO$ is half an equilateral triangle; so, $XO = \frac{r}{2}$.

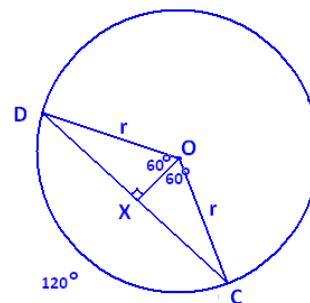

Thus, $DX = \sqrt{r^2 - \left(\frac{r}{2}\right)^2} = \frac{\sqrt{3}r}{2}$, and $DC = \sqrt{3}r$; so, $\frac{DC}{AB} = \sqrt{3}$.

4.

- a. An arc of a circle has length equal to the diameter of the circle. What is the measure of that arc in radian? Explain your answer.

An arc of length one radius of the circle represents one radian of turning. Thus, an arc of length two radii, a diameter, has a measure of 2 radian.

- b. Two circles have a common center O . Two rays from O intercept the circles at points A, B, C , and D as shown.

Suppose $OA : OB = 2 : 5$ and that the area of the sector given by A, O , and D is 10 cm^2 .

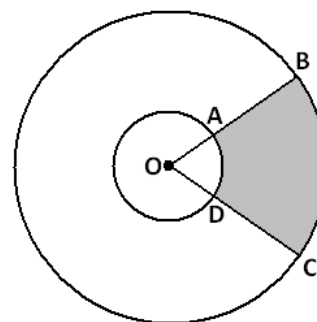

- i. What is the ratio of the measure of the arc AD to the measure of the arc BC ?

Both arcs represent the same amount of turning (i.e., they have the same central angle), so they have the same measure. This ratio is 1.

- ii. What is the area of the shaded region given by the points $A, B, C,$ and D ?

Let θ be the measure of $\angle AOD$ in radian. Since $OA : OB = 2 : 5$, we have that $OA = 2x$, and $OB = 5x$ for some value x .

Now the area of sector AOD is $10 \text{ cm}^2 = \frac{\theta}{2\pi} \cdot \pi(2x)^2 = 2\theta x^2$, so $\theta x^2 = 5 \text{ cm}^2$.

The area of sector BOC is $\frac{\theta}{2\pi} \cdot \pi(5x)^2 = \frac{25}{2} \theta x^2 = \frac{25}{2} (5 \text{ cm}^2) = \frac{125}{2} \text{ cm}^2$.

Thus, the area of the shaded region is $\frac{125}{2} \text{ cm}^2 - 10 \text{ cm}^2 = 52.5 \text{ cm}^2$.

(Alternatively: The sectors AOD and BOC are similar with scale factor $\frac{5}{2}$. Thus, the area of sector BOC is $10 \times \left(\frac{5}{2}\right)^2 = \frac{125}{2}$, and the area of the shaded region is $\frac{125}{2} - 10 = 52.5 \text{ cm}^2$.)

- iii. What is the ratio of the length of the arc AD to the length of the arc BC ?

Since the radii of the circles come in a 2 to 5 ratio, the same is true for these arc lengths.

5. In this diagram, the points $P, Q,$ and R are collinear and are the centers of three congruent circles. Q is the point of contact of two circles that are externally tangent. The remaining points at which two circles intersect are labeled $A, B, C,$ and D , as shown.

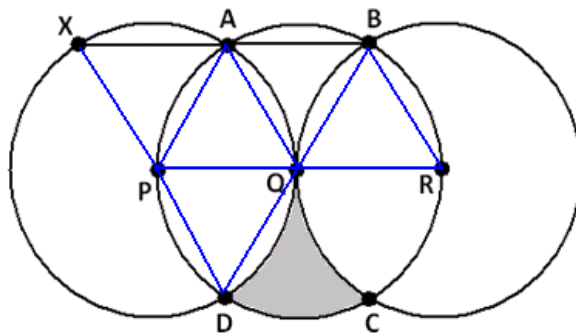

- a. Segment \overline{AB} is extended until it meets the circle with center P at a point X . Explain, in detail, why X , P , and D are collinear.

Draw in the radii shown.

Triangles APQ , QBR , and PQD are equilateral, so all angles in those triangles have measure 60° . $\triangle ABQ$ is isosceles with an angle at Q of measure $180^\circ - 60^\circ - 60^\circ = 60^\circ$. It follows that it is equilateral as well.

We have $m\angle XAP = 180^\circ - m\angle PAQ - m\angle QAB = 180^\circ - 60^\circ - 60^\circ = 60^\circ$. Since $\triangle XPA$ is isosceles, with one angle of measure 60° , it follows that it is also equilateral. In particular, $m\angle XPA = 60^\circ$.

Thus, $m\angle XPD = 60^\circ + 60^\circ + 60^\circ = 180^\circ$, showing that X , P , and D are collinear.

- b. In the diagram, a section is shaded. What percent of the full area of the circle with center Q is shaded?

Draw the segment \overline{AD} shown. We see that it divides a sector of the circle with center Q into two regions, which we have labeled I and II.

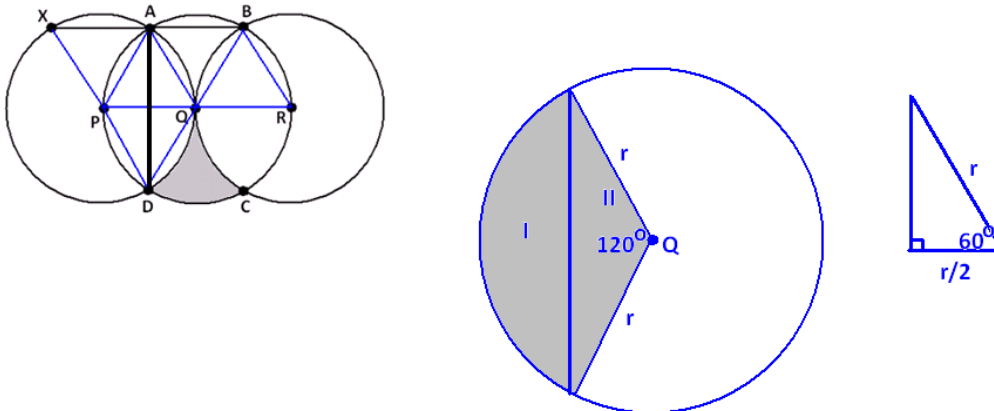

If we can determine the area of region I, then we see that the area of the desired shaded region is $\frac{1}{2}(\text{area full circle} - 4 \times \text{area I})$.

Now $\text{area}(I + II) = \frac{120}{360}\pi r^2 = \frac{1}{3}\pi r^2$, where r is the radius of the circle.

Region II is composed of two congruent right triangles, each containing a 60° angle and each with hypotenuse r . It follows that the remaining sides of each are $\frac{r}{2}$ and $\sqrt{r^2 - \left(\frac{r}{2}\right)^2} = \frac{\sqrt{3}r}{2}$. Thus, region II is a triangle with base $\sqrt{3}r$ and height $\frac{r}{2}$, so it has an area of $\frac{1}{2} \times \sqrt{3}r \times \frac{r}{2} = \frac{\sqrt{3}}{4}r^2$. We have $\text{area I} = \text{area}(I + II) - \text{area II} = \frac{1}{3}\pi r^2 - \frac{\sqrt{3}}{4}r^2$.

Thus, the shaded region in question has an area of

$$\frac{1}{2} \left(\pi r^2 - 4 \left(\frac{1}{3}\pi r^2 - \frac{\sqrt{3}}{4}r^2 \right) \right) = \frac{1}{2}\pi r^2 - \frac{2}{3}\pi r^2 = \left(\frac{\sqrt{3}}{2} - \frac{\pi}{6} \right) r^2.$$

The proportion of the full area πr^2 this represents is

$$\frac{\left(\frac{\sqrt{3}}{2} - \frac{\pi}{6} \right) r^2}{\pi r^2} = \frac{\sqrt{3}}{2\pi} - \frac{1}{6} \approx$$

$$\frac{1}{2} \left(\pi r^2 - 4 \left(\frac{1}{3}\pi r^2 - \frac{\sqrt{3}}{4}r^2 \right) \right) = \frac{1}{2}\pi r^2 - \frac{2}{3}\pi r^2 = \left(\frac{\sqrt{3}}{2} - \frac{\pi}{6} \right) r^2.$$

10.9%.



Topic C:

Secants and Tangents

G-C.A.2, G-C.A.3

Focus Standards:	G-C.A.2	Identify and describe relationships among inscribed angles, radii, and chords.
	G-C.A.3	Construct the inscribed and circumscribed circles of a triangle, and prove properties of angles for a quadrilateral inscribed in a circle.
Instructional Days:	6	
	Lesson 11:	Properties of Tangents (E) ¹
	Lesson 12:	Tangent Segments (P)
	Lesson 13:	The Inscribed Angle Alternate a Tangent Angle (E)
	Lesson 14:	Secant Lines; Secant Lines That Meet Inside a Circle (S)
	Lesson 15:	Secant Angle Theorem, Exterior Case (E)
	Lesson 16:	Similar Triangles in Circle-Secant (or Circle-Secant-Tangent) Diagrams (E)

Topic C focuses on secant and tangent lines intersecting circles, the relationships of angles formed, and segment lengths. In Lesson 11, students study properties of tangent lines and construct tangents to a circle through a point outside the circle and through points on the circle (**G-C.A.4**). Students prove that at the point of tangency, the tangent line and radius meet at a right angle. Lesson 12 continues the study of tangent lines proving segments tangent to a circle from a point outside the circle are congruent. In Lesson 13, students inscribe a circle in an angle and a circle in a triangle with constructions (**G-C.A.3**) leading to the study of inscribed angles with one ray being part of the tangent line (**G-C.A.2**). Students solve a variety of missing angle problems using theorems introduced in Lessons 11–13 (MP.1). The study of secant lines begins in Lesson 14 as students study two secant lines that intersect inside a circle. Students prove that an angle whose vertex is inside a circle is equal in measure to half the sum of arcs intercepted by it and its vertical angle. Lesson 15 extends this study to secant lines that intersect outside of a circle. Students understand that an angle whose vertex is outside of a circle is equal in measure to half the difference of the degree measure of its larger and smaller intercepted arcs. This concept is extended as the secant rays rotate to form tangent rays, and that relationship is developed. Topic C and the study of secant lines concludes in Lesson 16 as students discover the relationships between segment lengths of secant lines intersecting inside and outside of a circle. Students find similar triangles and use proportional sides to develop this relationship (**G-SRT.B.5**). Topic C highlights MP.1 as students persevere in solving missing angle and missing length problems; it also highlights MP.6 as students extend known relationships to limiting cases.

¹ Lesson Structure Key: P-Problem Set Lesson, M-Modeling Cycle Lesson, E-Exploration Lesson, S-Socratic Lesson



Lesson 11: Properties of Tangents

Student Outcomes

- Students discover that a line is *tangent* to a circle at a given point if it is perpendicular to the radius drawn to that point.
- Students construct tangents to a circle through a given point.
- Students prove that tangent segments from the same point are equal in length.

Lesson Notes

Topic C begins our study of secant and tangent lines. Lesson 11 is the introductory lesson and requires several constructions to solidify concepts for students. The study of tangents continues in Lessons 12 and 13.

During the lesson, recall the following definitions if necessary:

INTERIOR OF A CIRCLE: The *interior of a circle with center O and radius r* is the set of all points in the plane whose distance from the point O is less than r .

A point in the interior of a circle is said to be *inside the circle*. A disk is the union of the circle with its interior.

EXTERIOR OF A CIRCLE: The *exterior of a circle with center O and radius r* is the set of all points in the plane whose distance from the point O is greater than r .

A point exterior to a circle is said to be *outside the circle*.

Classwork

Opening (8 minutes)

- Draw a circle and a line.
 - *Students draw a circle and a line.*
- Have the students tape their sketches to the board.
- Let's group together the diagrams that are alike.

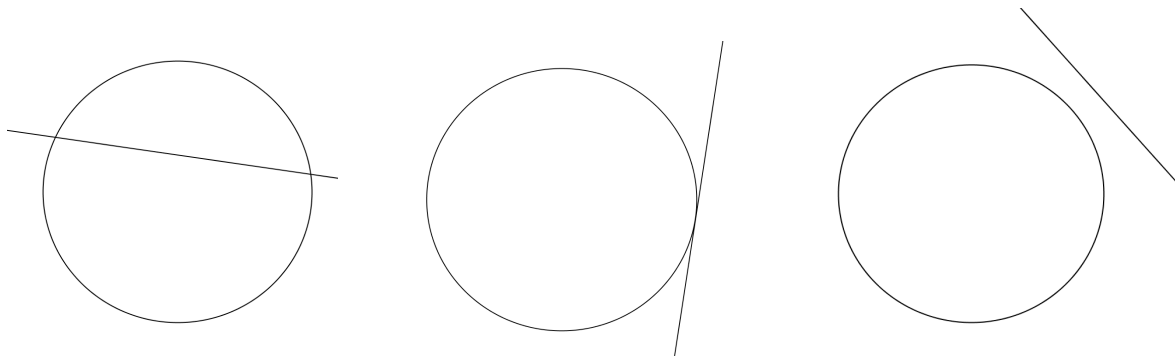

MP.6

- *Students should notice that some circles have lines that intersect the circle twice, others only touch the circle once, and others do not intersect the circle at all. Separate them accordingly.*
- Explain how the types of circle diagrams are different.
 - *A line can intersect a circle twice, only once, or not at all.*
- Do you remember the name for a line that intersects the circle twice?
 - *A line that intersects a circle at exactly two points is called a secant line.*
- Do you remember the name for a line that intersects the circle once?
 - *A line that intersects a circle at exactly one point is called a tangent line.*
- Label each group of diagrams as “secant lines,” “tangent lines,” and “don’t intersect,” and then as a class, repeat the definitions of secant and tangent lines chorally.
 - *SECANT LINE: A secant line to a circle is a line that intersects a circle in exactly two points.*
 - *TANGENT LINE: A tangent line to a circle is a line in the same plane that intersects the circle in one and only one point.*
 - *TANGENT SEGMENT: A segment is said to be a tangent segment to a circle if the line it is contained in is tangent to the circle, and one of its endpoints is the point where the line intersects the circle.*
- Topic C focuses on the study of secant and tangent lines intersecting circles.
- Explain to your neighbor the difference between a secant line and a tangent line.

Scaffolding:

- Post pictures of pairs of secant lines and tangent lines on the board so students can refer to them when needed.
- Post steps for each construction on the board for easy reference.
- Provide completed or partially completed drawings for students with eye-hand or fine motor difficulties or a set square to help with perpendicular lines and segments.
- For ELL students, use a Frayer diagram for all new vocabulary words and practice with choral repetition.

Exploratory Challenge (10 minutes)

In this whole class discussion, students will need a compass, protractor, and a straight edge to complete constructions.

- Draw a circle and a tangent line.
 - *Students draw a circle and a tangent line.*
- Draw a point where the tangent line intersects the circle. Label it *P*.
 - *Students draw the point and label it *P*.*
- Point *P* is called the point of tangency. Label point *P* as the “Point of Tangency,” and write its definition. Share your definition with your neighbor.
 - *The point of intersection of the tangent line to the circle is called the **point of tangency**.*
- Draw a radius connecting the center of the circle to the point of tangency.
 - *Students draw a radius to point *P*.*
- With your protractor, measure the angle formed by the radius and the tangent line. Write the angle measure on your diagram.
 - *Students measure and write 90° .*

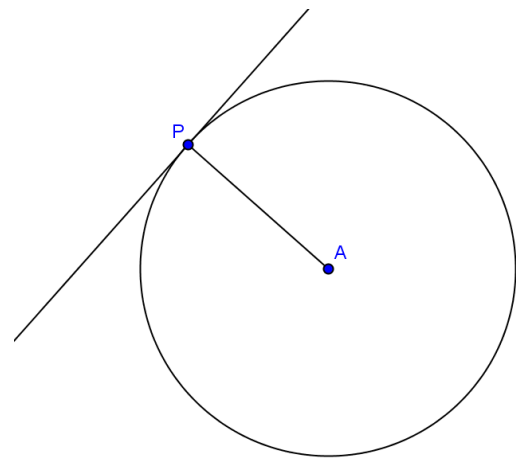

- Compare your diagram and angle measure to three people around you. What do you notice?
 - *All diagrams are different, but all angles are 90° .*
- What can we conclude about the segment joining a radius of a circle to the point of tangency?
 - *The radius and tangent line are perpendicular.*
- Let's think about other ways we can say this. What did we learn in Module 4 about the shortest distance between a line and a point?
 - *The shortest distance from a point to a line is the perpendicular segment from the point to the line.*
- So, what can we say about the center of the circle and the tangent line?
 - *The shortest distance between the center of the circle and a tangent line is at the point of tangency and is the radius.*
- We will say it one more way. This time restate what we have found relating the tangent line, the point of tangency, and the radius.
 - *A tangent line to a circle is perpendicular to the radius of the circle drawn to the point of tangency.*
- State the converse of what we have just said.
 - *If a line through a point on a circle is perpendicular to the radius drawn to that point, the line is tangent to the circle.*
- Is the converse true?
 - *Answers will vary.*
- Try to draw a line through a point on a circle that is perpendicular to the radius that is not tangent to the circle.
 - *Students will try but it will not be possible. If a student thinks he has a drawing that works show it to the class and discuss.*
- Share with your neighbor everything that you have learned about lines tangent to circles.
 - *The point where the tangent line intersects the circle is called the point of tangency.*
 - *A tangent line to a circle is perpendicular to the radius of the circle drawn to the point of tangency.*
 - *A line through a point on a circle is tangent at the point if, and only if, it is perpendicular to the radius drawn to the point of tangency.*

Scaffolding:

Post these steps with accompanying diagrams to assist/remind students.

Constructing a line perpendicular to a segment through a point.

- Extend the radius beyond the circle with center A , creating segment \overline{AB} .
- Draw point P at the point of intersection of \overline{AB} and the circle, using your compass, measure the distance from A to P and mark that on the extended radius.
- Draw circle A with radius AB .
- Draw circle B with radius BA .
- Mark the point of intersection of the circles points C and D .
- Construct a line through C and D .

Example 1 (12 minutes)

In this example, students will construct a tangent line through a given point on a circle and a tangent line to a given circle through a given point exterior to the circle (i.e., outside the circle). This lesson may have to be modified for students with eye-hand or fine motor difficulties. It could be done as a whole class activity where the teacher models the construction for everyone. Another option is to provide these students with an already complete step-by-step construction where each drawing shows only one step of the construction at a time. Students can try the next step but then will have an accurate drawing of the construction if they need assistance. Students should refer back to Module 1 for help on constructions.

Have students complete constructions individually, but pair students with a buddy who can help them if they struggle. Walk around the room and use this as an informal assessment of student understanding of constructions and lines tangent to a circle. Students will need a straight edge, a protractor, and a compass.

- Draw a circle and a radius intersecting the circle at a point labeled P .
 - *Students draw a circle and a radius and label point P .*
- Construct a line going through point P and perpendicular to the radius. Write the steps that you followed.
 - *Students draw a line perpendicular to the radius through P .*

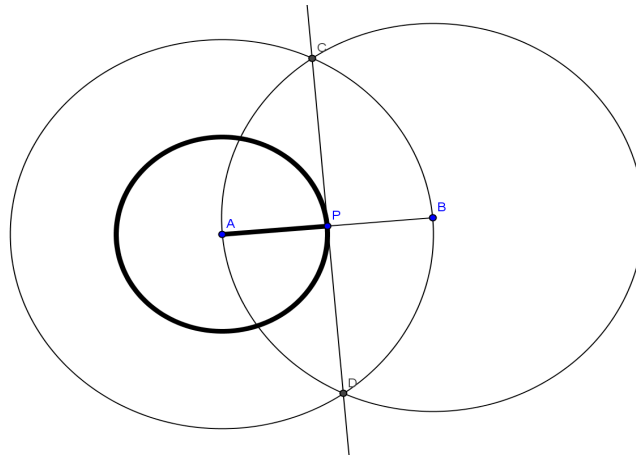

- Check students' constructions.
- Draw a circle A and a point exterior to the circle, and label it point R .
 - *Students construct a circle A and a point exterior to the circle labeled point R .*
- Construct a line through point R tangent to the circle A .
 - *This construction is difficult. Give students a few minutes to try, and then follow with the instructions that are below.*
- Draw segment \overline{AR} .
 - *Students draw segment \overline{AR} .*
- Construct the perpendicular bisector of \overline{AR} to find its midpoint. Mark the midpoint M .
- *Students construct the perpendicular bisector of \overline{AR} and mark the midpoint M .*
- Draw an arc of radius MA with center M intersecting the circle. Label this point of intersection as point B .
 - *Students draw an arc intersecting the circle and mark the point of intersection as point B .*
- Draw line \overleftrightarrow{RB} and segment \overline{AB} .
 - *Students draw line R and segment \overline{AB} .*
- Is $\overleftrightarrow{RB} \perp \overline{AB}$? Verify the measurement with your protractor.
 - *Students verify that the line and radius are perpendicular.*
- What does this mean?
 - *Line \overleftrightarrow{RB} is a tangent line to circle A at point B .*

- Repeat this process, and draw another line through point R tangent to circle A , intersecting the circle at point C .
 - *Students repeat the process, and this time the tangent line intersects the other side of the circle.*

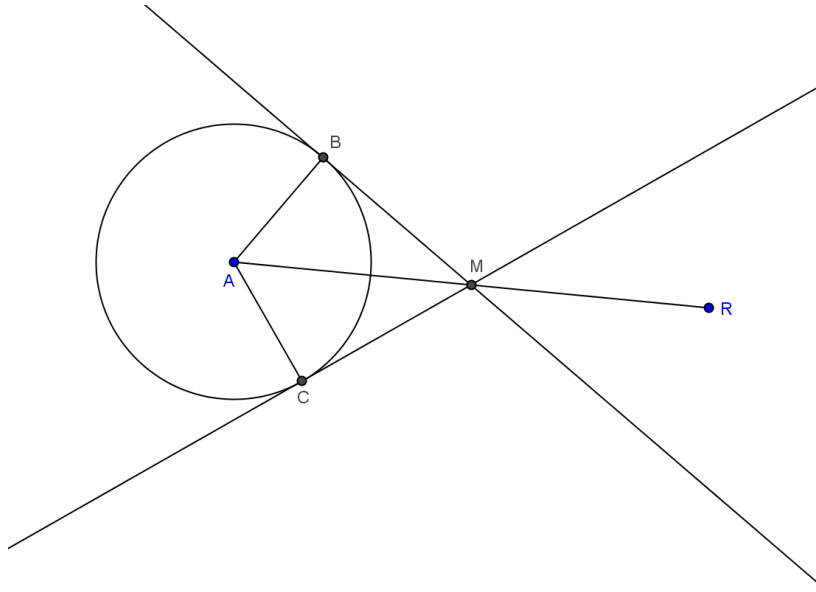

- What is true about MB , MA , MR , and MC ?
 - *They are all the same length.*
- Let's remember that! It may be useful for us later.

Exercises 1–3 (7 minutes)

This proof requires students to understand that tangent lines are perpendicular to the radius of a circle at the point of tangency and then to use their previous knowledge of similar right triangles to prove $a = b$. Have students work in homogeneous pairs, helping some groups if necessary. Pull the entire class together to share proofs and see different methods used. Correct any misconceptions.

Exercises 1–3

1. \overline{CD} and \overline{CE} are tangent to circle A at points D and E respectively. Use a two-column proof to prove $a = b$.

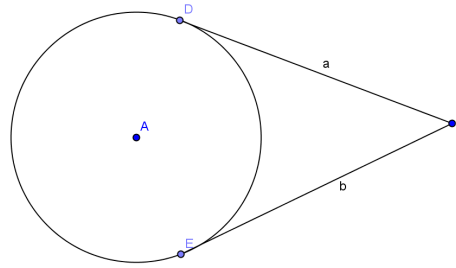

Draw radii \overline{AD} and \overline{AE} and segment \overline{AC} .

$CD = a, CE = b$

$\angle ADC$ and $\angle AEC$ are right angles.

$\triangle ADC$ and $\triangle AEC$ are right triangles.

$AD = AE$

$AC = AC$

$\triangle ADC \cong \triangle AEC$.

$CD = CE$

$a = b$

Given

Tangent lines are perpendicular to the radius at the point of tangency.

Definition of a right triangle

Radii of the same circle are equal in measure.

Reflexive property

HL

CPCTC

Substitution

1. In circle A , the radius is 9 mm and $BC = 12$ mm.

- a. Find AC .

$AC = 15$ mm

- b. Find the area of $\triangle ACD$.

$A = 54$ mm²

- c. Find the perimeter of quadrilateral $ABCD$.

$P = 42$ mm

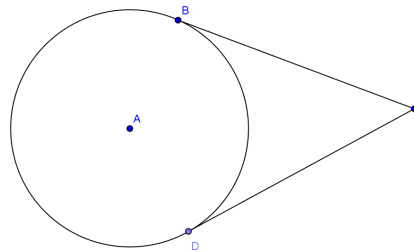

3. In circle A , $EF = 12$ and $AE = 13$. $AE:AC = 1:3$. Find

- a. The radius of the circle.

5

- b. BC (round to the nearest whole number)

39

- c. EC

51

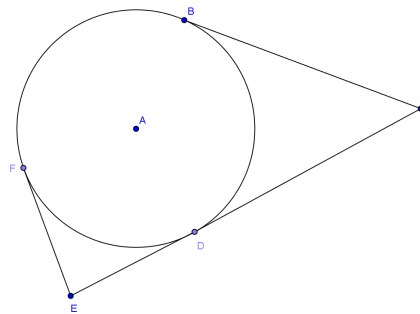

Closing (3 minutes)

Project the picture to the right. Have students do a 30 second quick write on all they know about the diagram if:

\overrightarrow{FB} is tangent to the circle at point B .

\overrightarrow{EC} is tangent to the circle at point E .

\overrightarrow{DC} is tangent to the circle at point D .

Then have the class as a whole share their ideas.

- $\overline{AE} \perp \overline{CE}$, $\overline{AB} \perp \overline{FB}$, $\overline{AD} \perp \overline{CD}$
- $CE = CD$
- $AB = AE = AD$

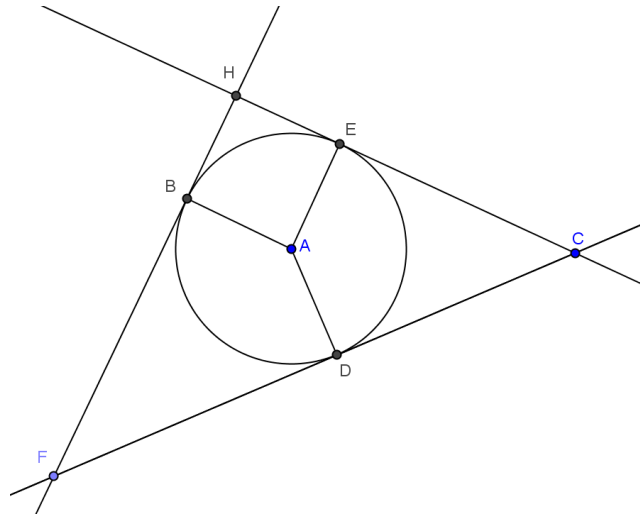

Lesson Summary

THEOREMS:

- A tangent line to a circle is perpendicular to the radius of the circle drawn to the point of tangency.
- A line through a point on a circle is tangent at the point if, and only if, it is perpendicular to the radius drawn to the point of tangency.

Relevant Vocabulary

- **INTERIOR OF A CIRCLE:** The interior of a circle with center O and radius r is the set of all points in the plane whose distance from the point O is less than r .
A point in the interior of a circle is said to be *inside the circle*. A disk is the union of the circle with its interior.
- **EXTERIOR OF A CIRCLE:** The exterior of a circle with center O and radius r is the set of all points in the plane whose distance from the point O is greater than r .
A point exterior to a circle is said to be *outside the circle*.
- **TANGENT TO A CIRCLE:** A *tangent line to a circle* is a line in the same plane that intersects the circle in one and only one point. This point is called the *point of tangency*.
- **TANGENT SEGMENT/RAY:** A segment is a *tangent segment to a circle* if the line that contains it is tangent to the circle and one of the end points of the segment is a point of tangency. A ray is called a *tangent ray to a circle* if the line that contains it is tangent to the circle and the vertex of the ray is the point of tangency.
- **SECANT TO A CIRCLE:** A *secant line to a circle* is a line that intersects a circle in exactly two points.
- **POLYGON INSCRIBED IN A CIRCLE:** A polygon is *inscribed in a circle* if all of the vertices of the polygon lie on the circle.
- **CIRCLE INSCRIBED IN A POLYGON:** A circle is *inscribed in a polygon* if each side of the polygon is tangent to the circle.

Exit Ticket (5 minutes)

Name _____

Date _____

Lesson 11: Properties of Tangents

Exit Ticket

- If $BC = 9$, $AB = 6$, and $AC = 15$, is line \overleftrightarrow{BC} tangent to circle A ? Explain.

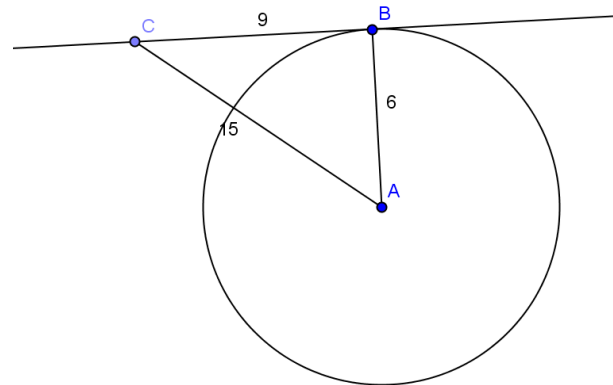

- Construct a line tangent to circle A through point B .

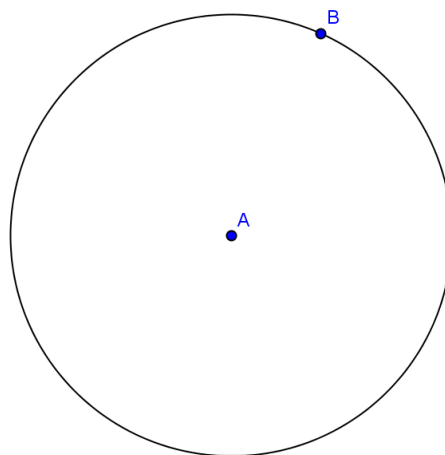

Exit Ticket Sample Solutions

1. If $BC = 9$, $AB = 6$, and $AC = 15$, is line \overleftrightarrow{BC} tangent to circle A ? Explain.

No, $\triangle ABC$ is not a right triangle because $9^2 + 6^2 \neq 15^2$. This means \overline{AB} is not perpendicular to \overline{BC} .

2. Construct a line tangent to circle A through point B .

Problem Set Sample Solutions

Problems 1–6 should be completed by all students. Problems 7 and 8 are more challenging and can be assigned to some students for routine work and others as a student choice challenge.

1. If $AB = 5$, $BC = 12$, and $AC = 13$, is \overleftrightarrow{BC} tangent to circle A at point B ? Explain.

Yes, $\triangle ABC$ is a right triangle because the Pythagorean theorem holds $5^2 + 12^2 = 13^2$. Angle B is right, so $\overline{AB} \perp \overline{BC}$; therefore, \overleftrightarrow{BC} is tangent to circle A at point B .

2. \overline{BC} is tangent to circle A at point B . $DC = 9$ and $BC = 15$.

a. Find the radius of the circle.

$r = 8$

b. Find AC .

$AC = 17$

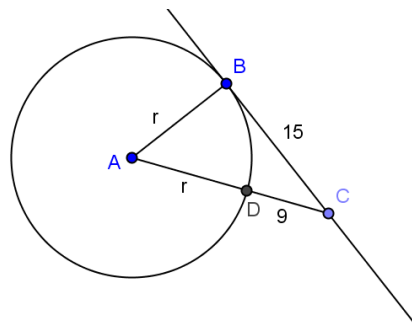

3. A circular pond is fenced on two opposite sides (\overline{CD} , \overline{FE}) with wood and the other two sides with metal fencing. If all four sides of fencing are tangent to the pond, is there more wood or metal fencing used?

There is an equal amount of wood and metal fencing because the distance from each corner to the point of tangency is the same.

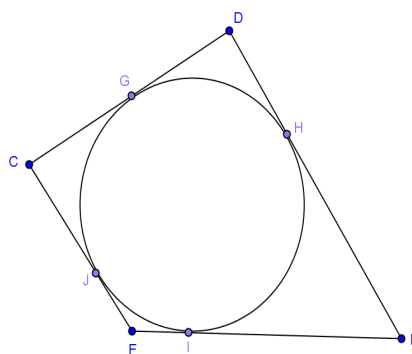

4. Find x if the line shown is tangent to the circle at point B .

67°

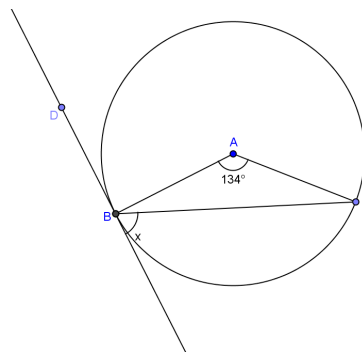

5. Line \overline{PC} is tangent to the circle at point C , and $CD = DE$.
Find

a. $x(m\widehat{CD})$
 104°

b. $y(m\angle CFE)$
 104°

c. $z(m\angle PCF)$
 38°

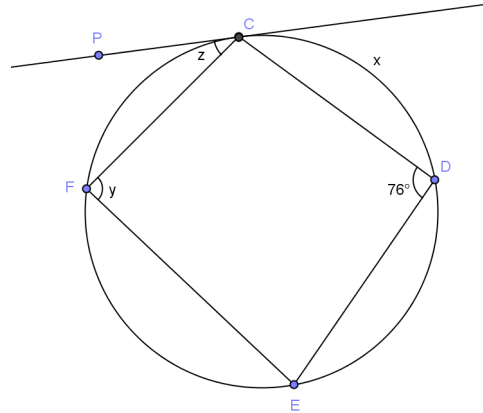

6. Construct two lines tangent to circle A through point B .

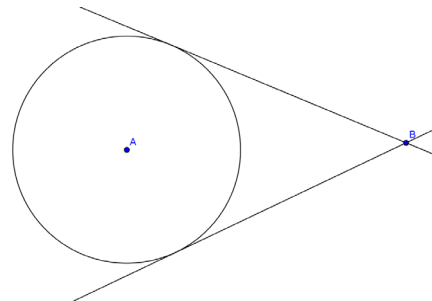
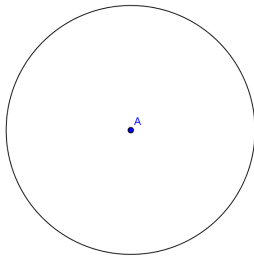

7. Find x , the length of the common tangent line between the two circles (round to the nearest hundredth).
 $x = 11.83$

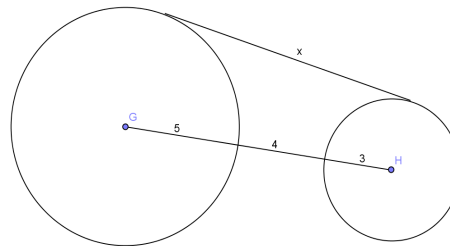

8. \overline{EF} is tangent to both circles A and C . The radius of circle A is 9, and the radius of circle C is 5. The circles are 2 units apart. Find the length of \overline{EF} , x (round to the nearest hundredth).

$x = 7.75$

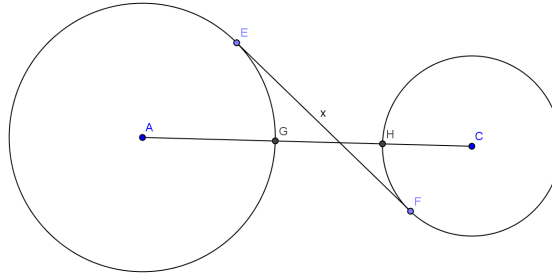



Lesson 12: Tangent Segments

Student Outcomes

- Students use *tangent segments* and *radii of circles* to conjecture and prove geometric statements, especially those that rely on the congruency of tangent segments to a circle from a given point.
- Students recognize and use the fact if a circle is tangent to both rays of an angle, then its center lies on the *angle bisector*.

Lesson Notes

The common theme of all the lesson activities is tangent segments and radii of circles can be used to conjecture and prove geometric statements.

Students first conjecture and prove that if a circle is tangent to both rays of an angle, then its center lies on the angle bisector. After extrapolating that every point on an angle bisector can be the center of a circle tangent to both rays of the angle, students show that there exists a circle simultaneously tangent to two angles with a common side. Finally, students conjecture and prove that the three angle bisectors of a triangle intersect at a single point and prove that this single point is the center of a circle inscribed in the triangle.

Classwork

Opening Exercise (5 minutes)

Students apply the theorem from Lesson 11, two segments tangent to a circle from a point outside the circle are congruent. This theorem will be used in proofs of this lesson’s main results. Once you state the theorem below and ask the question, review Exercise 1 from Lesson 11, or have students discuss the proof to make sure students understand the theorem.

Scaffolding:

- Give students the theorem from Lesson 11 if they need help getting started.
- **THEOREM:** Two segments tangent to a circle from an exterior point are congruent.

Opening Exercise

In the diagram to the right, what do you think the length of z could be? How do you know?

$z = 8$ because each successive segment is tangent to the same circle so the segments are congruent.

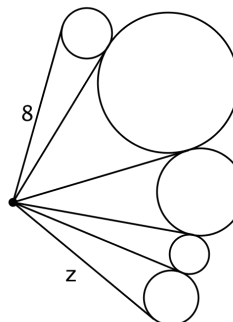

MP.7

- Can someone say, in your own words, the theorem used to determine z ?
 - *Students explain the theorem in their own words.*

- How did you use this theorem to find z ?
 - *Each successive segment was tangent to the same circle, so they were congruent.*
- How many times did you use this theorem?
 - *5 times*
- Summary: By applying this theorem and transitivity over and over again, you found that each of the tangent segments has equal length, so $z = 8$.

Example 1 (7 minutes)

The point of this example is to understand why the following statement holds: *If a circle is tangent to both rays of an angle, then its center lies on the angle bisector.* Students explore this statement by investigating the contrapositive: attempting to draw such circles when the center is not on the angle bisector and reasoning why this cannot be done.

Example 1

In each diagram, try to draw a circle with center D that is tangent to both rays of the angle $\angle BAC$.

a.

b.

c.

Which diagrams did it seem impossible to draw such a circle? Why did it seem impossible?

(a) Impossible; (b) possible; (c) impossible. It's not possible to draw a circle tangent to both rays of the angle in (a) and (c) because D is a different distance from the two sides of the angle. The distance is the radius of a circle tangent to that side.

What do you conjecture about circles tangent to both rays of an angle? Why do you think that?

If a circle is tangent to both rays of an angle, then the center lies on the angle bisector. We saw this in all examples.

MP.3

- How many people were able to draw a circle for (a)? (b)? (c)?
 - *It was not possible to draw such a circle for (a) and (c), but it did seem possible for (b).*
- What is special about (b) that wasn't true for (a) and (c)?
 - *The point D was more in the middle of the angle in (b) than in (a) or (c).*
 - *The point D is on the angle bisector.*
- Why did this make a difference?
 - *You couldn't make a circle that was tangent to both sides at the same time because the center was too far or too close to one side of the angle.*

- (If students do not see that D must be on the angle bisector) Suppose you were given a different angle. Create different angles or have students draw some samples. Which of these points would you pick as the center of a circle tangent to both rays? How about these? How about these? What do you notice about the possible centers? (Draw two points, one that could be on the angle bisector and one that is obviously not; continue giving different examples until it is apparent that the set of viable centers is likely the angle bisector.)
- State what we have just discovered to your neighbor.
 - **CONJECTURE:** *If a circle is tangent to both rays of an angle, then the center of the circle lies on the angle bisector.*

Exercises 1–5 (25 minutes)

Allow students to work in pairs or groups to complete the exercises. You may assign certain groups particular problems and call the class together to share results. Some groups may need more guidance on these exercises.

Students first prove the conjecture made in Example 1, and it becomes a theorem. This theorem allows us to resolve the mystery opened in the last lesson: Does every triangle have an inscribed circle? Exercises 2–5 trace the mathematical steps from the proof of the Example 1 conjecture to the construction of the circle inscribed in a given triangle.

Throughout these exercises, emphasize that the definition of *angle bisector* is the set of points equidistant from the rays of an angle. Make sure students understand this means *both* that given any point on the angle bisector, the perpendiculars dropped from this point to the rays of the angle must be the same length *and* that if the dropped perpendiculars are the same length, then the point from which the perpendiculars are dropped must be on the angle bisector. These observations are critical for all the exercises and especially for Exercises 3–5.

Exercise 1 notes. The point of Exercise 1 is the following theorem.

THEOREM: *If a circle is tangent to both rays of an angle, then its center lies on the angle bisector.*

To get at the proof of this theorem, you might first poll students as to whether they used congruent triangles to show the conjecture; ask which triangles. If students ask how this proof is different from the Opening Exercise, you can point out that both proofs use the same pair of congruent triangles to draw their conclusions. However, in the Opening Exercise, the application of CPCTC (corresponding parts of congruent triangles are congruent) is for showing two legs are congruent, whereas here it is for two angles.

Exercise 2 notes. The point of Exercise 2 is the following construction, whose mathematical validity is a consequence of the theorem proven in Exercise 1.

CONSTRUCTION: The following constructs a circle tangent to both rays of a given angle: (1) Construct the angle bisector of the given angle; (2) Select a point of the bisector to be the center; (3) Drop a perpendicular from the selected point to the angle to find the radius; (4) Construct a circle with that center and radius.

A discussion could proceed: How did you construct the center of the circle? The radius? (Select a center from the points on the angle bisector; drop a perpendicular to find the radius.) We sometimes say that the angle bisector is the set of points equidistant from the two rays of the angle. How do you know that the distance from each of your centers to the two rays of the angle is the same? (If P is the center of a circle with tangents to the circle at C and B , then PC and PB are radii of the circle, and all radii have the same length) Why do we know that the radius is the distance from the center to the tangent line? (The radii are perpendicular to the rays.)

Exercise 3 notes. The point of Exercise 3 is applying Exercise 2 to the condition that the desired circle must have a center lying on angle bisectors of two angles. The key points of the argument are (1) finding a potential center of the circle, (2) finding a potential radius of the circle, and (3) establishing that a circle with this center and radius is tangent to both rays of both angles.

The reasoning for the key points could be the following: (1) The angle bisectors of two angles intersect in only one point, and if there is such a circle, the center of that circle must be the intersection point. (2) A potential radius is the length of the perpendicular segment from this center to the common side shared by the angles; a line intersects a circle in one point if and only if it is perpendicular to the radius at that point. (3) The circle with this radius and center is tangent to both rays of both angles, and it is the only circle. This is because the angle bisector is the set of points equidistant from the two sides, so the perpendicular segments from the potential center to the rays of the angle are all congruent (since the distance is defined as the length of the perpendicular segment). There is only one such circle because there is only one intersection point, and the distance from this point to the rays of the angle is well defined.

Exercise 4 notes. The point of Exercise 4 is extending the reasoning from Exercise 3 to conclude that all three-angle bisectors of a triangle meet at a single point, so finding the intersection of any two points suffices. Central to Exercise 4 is the definition of angle bisector. The key idea of the argument is that the intersection point of the angle bisectors of any two consecutive angles is the same distance from both rays of both angles.

Exercise 5 notes. Exercise 5 applies Exercise 4.

Exercises 1–5

1. You conjectured that *if a circle is tangent to both rays of a circle, then the center lies on the angle bisector.*

a. Rewrite this conjecture in terms of the notation suggested by the diagram.

Given:

Circle with center P and tangent to AB and AC; $x = m\angle CAP$; $y = \angle BAP$

Need to show:

$x = y$

b. Prove your conjecture using a two column proof.

<p>$m\angle CAP = x, m\angle BAP = y$</p> <p>$\overline{PC} \perp \overline{AC}, \overline{PB} \perp \overline{AB}$</p> <p>$\triangle ABP$ and $\triangle ACP$ are right triangles</p> <p>$AP = AP$</p> <p>$PB = PC$</p> <p>$\triangle ABP \cong \triangle ACP$</p> <p>$m\angle BAP = m\angle CAP$</p> <p>$x = y$</p> <p>$\overline{AP}$ bisects $\angle CAB$</p>	<p>Given</p> <p><i>Tangent is perpendicular to the radius at the point of tangency.</i></p> <p><i>Definition of right triangle</i></p> <p><i>Reflexive property</i></p> <p><i>Radii of the same circle are equal in length.</i></p> <p>HL</p> <p>CPCTC</p> <p>Substitution</p> <p><i>Definition of angle bisector</i></p>
--	---

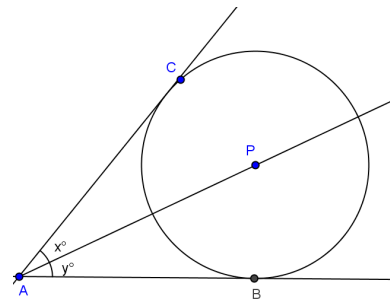

2. An angle is shown below.

a. Draw at least 3 different circles that are tangent to both rays of the given angle.

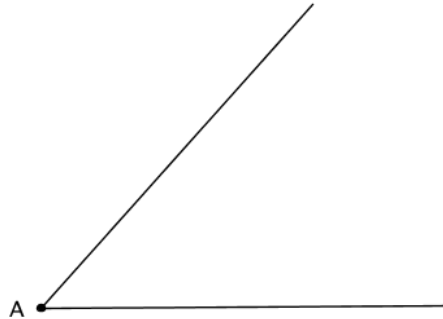

Many circles are possible. The main idea is that the center must be a point on the angle bisector, and the radius is the perpendicular from the center to the rays of the angle.

b. Label the center of one of your circles with P . How does the distance between P and the rays of the angle compare to the radius of the circle? How do you know?

The distance between P and the rays of the angle is the same length as the radius of the circle because it is perpendicular to tangent segments as proved last lesson.

3. Construct as many circles as you can that are tangent to both the given angles at the same time. You can extend the rays as needed. These two angles share a side.

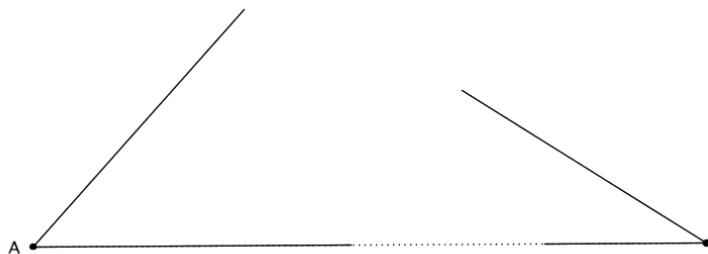

Explain how many circles you can draw to meet the above conditions and how you know.

There is only one circle. The center of the circle has to be on the angle bisector of each angle; the angle bisectors only intersect in one point. There is only one circle with that point as a center that is tangent to the rays. It is the one with the radius you get by dropping the perpendicular from the point to the side A .

4. In a triangle, let P be the location where two angle bisectors meet. Must P be on the third angle bisector as well? Explain your reasoning.

The angle bisectors of any two consecutive angles are the same distance from both rays of both angles. Let the vertices of the triangle be A , B , and C where $m\angle A = 2x$, $m\angle B = 2y$, and $\angle C = 2z$. If point P is on the angle bisector of $\angle A$ and $\angle B$, then it is the same distance from AB and AC , and it is the same distance from BA and BC . Thus, it is the same distance from CA and CB ; therefore, it is on the angle bisector of $\angle C$.

5. Using a straightedge, draw a large triangle ABC .

a. Construct a circle inscribed in the given triangle.

Construct angle bisectors between any two angles. Their intersection point will be the center of the circle. Drop a perpendicular from the intersection point to any side. This will be a radius. Draw the circle with that center and radius.

b. Explain why your construction works.

The point P from Exercise 4 is the same distance from all three sides of $\triangle ABC$. Thus, the perpendicular segments from P to each side are the same length. A line is tangent to a circle if and only if the line is perpendicular to a radius where the radius meets the circle. Therefore, a circle with center P and radius the length of the perpendicular segments from P to the sides is inscribed in the triangle.

c. Do you know another name for the intersection of the angle bisectors in relation to the triangle?

The intersection of the angle bisectors is the incenter of the triangle.

Closing (3 minutes)

Have a whole-class discussion of the topics studied today. Also, go through any questions that came up during the exercises.

Today we saw why any point on an angle bisector is the center of a circle that is tangent to both rays of an angle but that any point that's not on the angle bisector cannot possibly be the center of such a circle. This means that we can construct a circle tangent to both rays of an angle by first constructing the angle bisector, selecting a point on it, and then dropping a perpendicular to find the radius. We put this all together to solve a mystery we raised yesterday:

- Do all triangles have inscribed circles?
 - *We found the answer is yes!*

The theme of all our constructions today, and for the homework, is that tangent segments and radii of circles are incredibly useful for conjecturing and proving geometric statements.

- What did we discover from our constructions today?
 - *The two tangent segments to a circle from an exterior point are congruent.*
 - *If a circle is tangent to both rays of an angle, then its center lies on the angle bisector.*
 - *Every triangle contains an inscribed circle whose center is the intersection of the triangle's angle bisectors.*

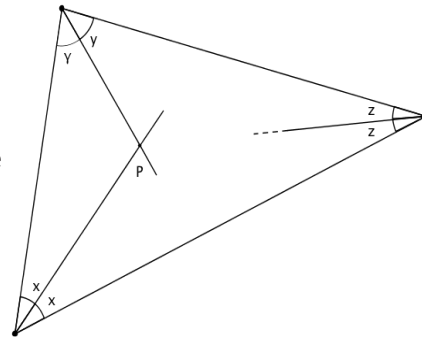

Lesson Summary

THEOREMS:

- The two tangent segments to a circle from an exterior point are congruent.
- If a circle is tangent to both rays of an angle, then its center lies on the angle bisector.
- Every triangle contains an inscribed circle whose center is the intersection of the triangle's angle bisectors.

Exit Ticket (5 minutes)

Name _____

Date _____

Lesson 12: Tangent Segments

Exit Ticket

1. Draw a circle tangent to both rays of this angle.

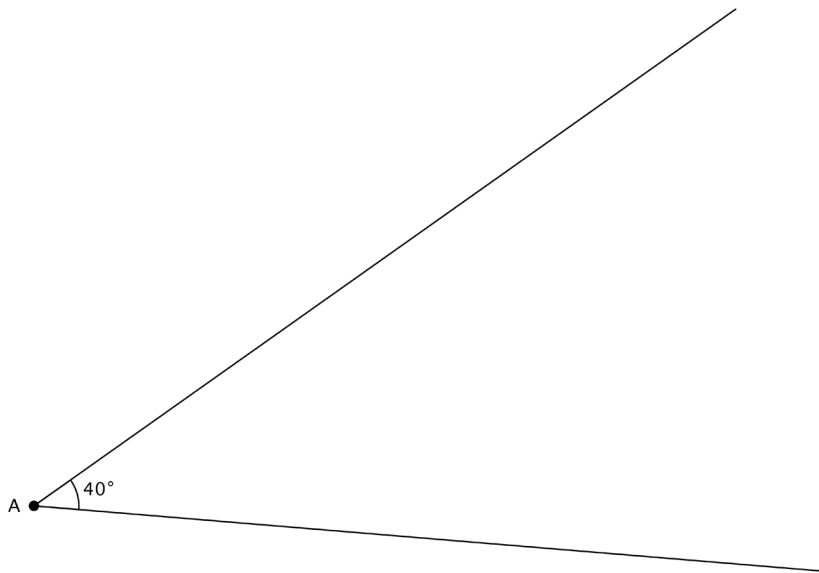

2. Let B and C be the points of tangency of your circle. Find the measures of $\angle ABC$ and $\angle ACB$. Explain how you determined your answer.
3. Let P be the center of your circle. Find the measures of the angles in $\triangle APB$.

Exit Ticket Sample Solutions

1. Construct a circle tangent to both rays of this angle.

Lots of circles are possible. Check that the center of the circle is on the angle bisector and the radius is from a perpendicular from the center to a ray of the angle.

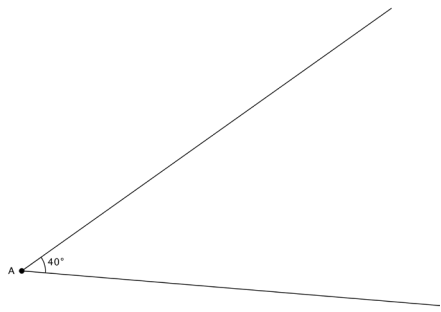

2. Let B and C be the points of tangency of your circle. Find the measures of $\angle ABC$ and $\angle ACB$. Explain how you determined your answer.

Triangle $\triangle ABC$ is isosceles because the tangent segments AB and AC are congruent, so

$$m\angle ABC = m\angle ACB = \frac{180^\circ - 40^\circ}{2} = 70^\circ$$

3. Let P be the center of your circle. Find the measures of the angles in $\triangle APB$.

In triangle $\triangle APB$, the angle at A measures 20° , at P measures 70° , and at B is 90° .

Problem Set Sample Solutions

It is recommended to assign Problem 8. This problem is used to open Lesson 12.

Problems 1 – 7 rely heavily on the fact that *two tangents from a given exterior point are congruent* and, hence, that *if a circle is tangent to both rays of an angle, then the center of the circle lies on the angle bisector*; these problems may also do arithmetic on lengths of tangent segments.

Problem 8 examines angles between tangent segments and chords.

Problems involving proofs may take a while, so they can be assigned as student choice.

1. On a piece of paper, draw a circle with center A and a point, C , outside of the circle.

a. How many tangents can you draw from C to the circle?

2 tangents.

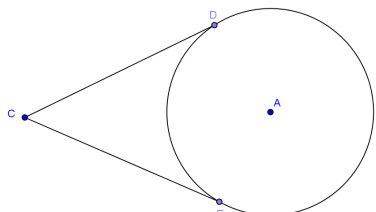

- b. Draw two tangents from C to the circle, and label the tangency points D and E . Fold your paper along the line AC . What do you notice about the lengths of CD and CE ? About the measures of the angles $\angle DCA$ and $\angle ECA$?

The lengths are the same; the angles are congruent.

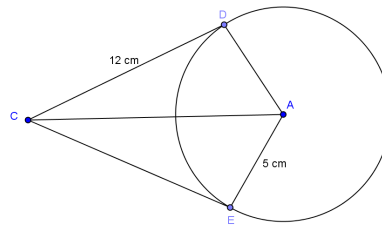

- c. AC is the _____ of $\angle DCE$.

Angle bisector

- d. \overline{CD} and \overline{CE} are tangent to circle A . Find AC .

$AC = 13$ by the Pythagorean theorem.

2. In the figure at right, the three segments are tangent to the circle at points B , F , and G . If $y = \frac{2}{3}x$, find x , y , and z .

Tangents to a circle from a given point are congruent. So $EF = EG = x$, $GD = BD = y$, and $BC = CF = z$. This allows us to set up a system of simultaneous linear equations that can be solved for x , y , and z .

$$x + z = 48, x + y = 45, y + z = 39$$

$$x = 27, y = 18, z = 21$$

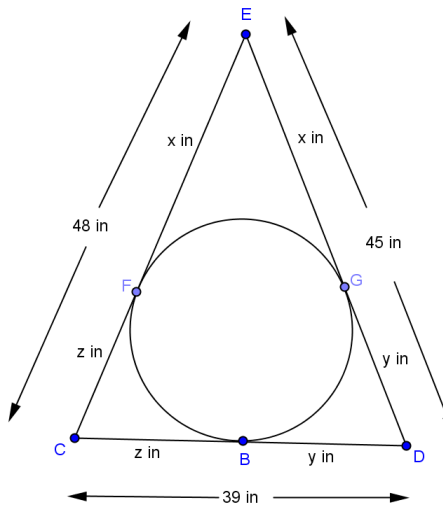

3. In the figure given, the three segments are tangent to the circle at points J , I , and H .

- a. Prove $GF = GJ + HF$

$GJ = GI$ and $FI = FH$ because tangents to a circle from a given point are congruent.

$GF = GI + IF$ sum of segments

$GF = GJ + HF$ by substitution

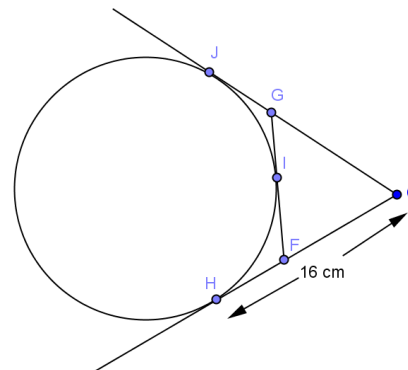

b. Find the perimeter of $\triangle GCF$.

$CH = 16$

$GJ = GI, IF = FH, CJ = CH$ tangents to a circle from a given point are congruent.

$CJ = GC + GJ, CH = CF + FH$ sum of segments

Perimeter = $GC + CF + GF$

$GC + CF + (GI + IF)$ by substitution

$GC + GI + CF + IF$

$GC + GJ + CF + FH$ by substitution

$CJ + CH$ by substitution

$2CH = 2(16 \text{ cm}) = 32 \text{ cm}$

4. In the given figure, the three segments are tangent to the circle at point $F, B,$ and G . Find DE .

7 m

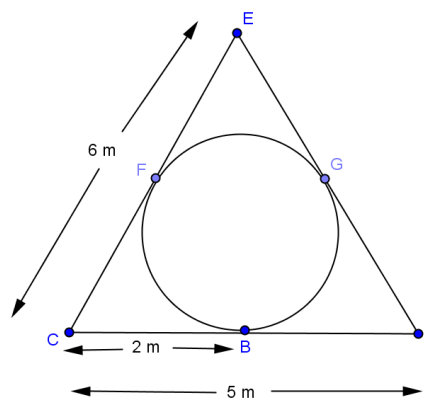

5. \overline{EF} is tangent to circle A . If points C and D are the intersection points of circle A and any line parallel to \overline{EF} , answer the following.

a. Does $CG = GD$ for any line parallel to \overline{EF} ? Explain.

Yes. No matter what, $\triangle ACD$ is an isosceles triangle, and AG is the altitude to the base of the triangle and, therefore, the angle bisector of the angle opposite the base.

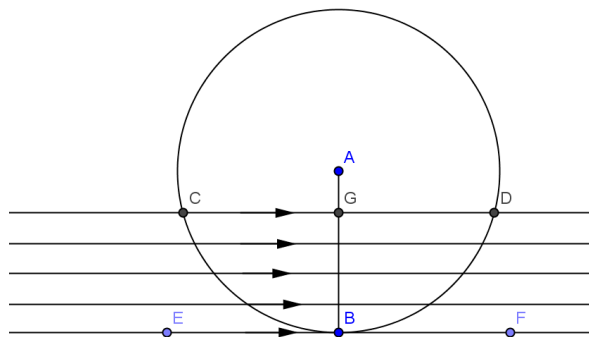

b. Suppose that \overline{CD} coincides with \overline{EF} . Would $C, G,$ and D all coincide with B ?

Yes. If they approached B at different times, then at some point G would not be on the same line as C and D , but G is defined to be contained in the chord \overline{CD} .

c. Suppose $C, G,$ and D have now reached B , so \overline{CD} is tangent to the circle. What is the angle between the line \overline{CD} and \overline{AB} ?

90° . A line tangent to a circle is perpendicular to the radius at the point of tangency.

- d. Draw another line tangent to the circle from some point, P , in the exterior of the circle. If the point of tangency is point T , what is the measure of $\angle PTA$?

The measure of angle PTA is 90° because a line tangent to a circle is perpendicular to a radius through the tangency point.

6. The segments are tangent to circle A at points B and D . \overline{ED} is a diameter of the circle.

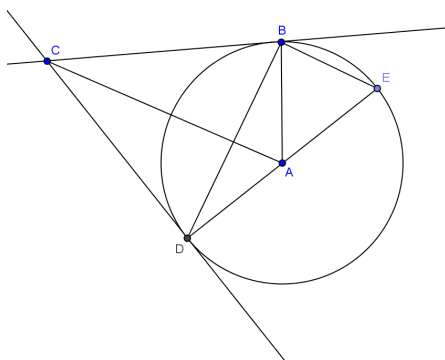

- a. Prove $\overline{BE} \parallel \overline{CA}$.

$$m\angle E = \frac{1}{2} m\angle BAD$$

Inscribed angle is half the central angle that intercepts the same arc.

\overline{AC} bisects $\angle BAD$

If a circle is tangent to both rays of an angle, then its center lies on the angle bisector.

$$m\angle E = m\angle BAC$$

Substitution

$\overline{BE} \parallel \overline{CA}$

If two lines are cut by a transversal such that the alternate interior angles are congruent, then the lines are parallel.

- b. Prove quadrilateral $ABCD$ is a kite.

$$CB = CD$$

tangents to a circle from a given point are congruent.

$$AB = AD$$

radii are congruent.

Quadrilateral $ABCD$ is a kite because two pairs of adjacent sides are congruent.

7. In the diagram shown, \overline{BH} is tangent to the circle at point B . What is the relationship between $\angle DBH$, the angle between the tangent and a chord, and the arc subtended by that chord and its inscribed angle $\angle DCB$?

$$m\angle DBH = m\angle DCB$$

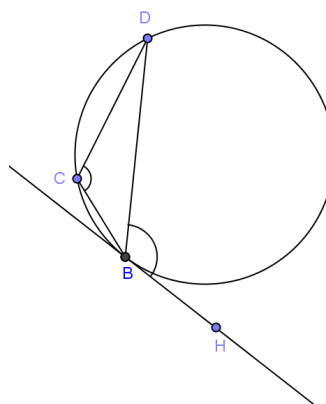



Lesson 13: The Inscribed Angle Alternate a Tangent Angle

Student Outcomes

- Students use the inscribed angle theorem to prove other theorems in its family (different angle and arc configurations and an arc intercepted by an angle at least one of whose rays is tangent).
- Students solve a variety of missing angle problems using the inscribed angle theorem.

Lesson Notes

The Opening Exercise reviews and solidifies the concept of inscribed angles and their intercepted arcs. Students then extend that knowledge in the remaining examples to the limiting case of inscribed angles, one ray of the angle is tangent. Example 1 looks at a tangent and secant intersecting on the circle. Example 2 uses rotations to show the connection between the angle formed by the tangent and a chord intersecting on the circle and the inscribed angle of the second arc. Students then use all of the angle theorems studied in this topic to solve missing angle problems.

Classwork

Opening Exercise (5 minutes)

This exercise solidifies the relationship between inscribed angles and their intercepted arcs. Have students complete this exercise individually and then share with a neighbor. Pull the class together to answer questions and discuss part (g).

Scaffolding:

- Post diagrams showing key theorems for students to refer to.
- Use scaffolded questions with a targeted small group such as, “What do we know about the measure of the intercepted arc of an inscribed angle?”

In circle A , $m\widehat{BD} = 56^\circ$, and \overline{BC} is a diameter. Find the listed measure, and explain your answer.

- $m\angle BDC$
 90° , angles inscribed in a diameter
- $m\angle BCD$
 28° , inscribed angle is half measure of intercepted arc
- $m\angle DBC$
 62° , sum of angles of a triangle is 180°
- $m\angle BFG$
 28° , inscribed angle is half measure of intercepted arc

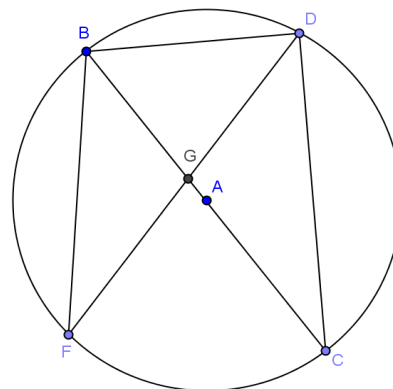

e. $m\widehat{BC}$
 180° , semicircle

f. $m\widehat{DC}$
 124° , intercepted arc is double inscribed angle

g. Is the $m\angle BGD = 56^\circ$? Explain.
 No, the central angle of arc \widehat{BD} would be 56° . $\angle BGD$ is not a central angle because its vertex is not the center of the circle.

h. How do you think we could determine the measure of $\angle BGD$?
 Answers will vary. This leads to today's lesson.

Example 1 (15 minutes)

In the Lesson 12 homework, students were asked to find a relationship between the measure of an arc and an angle. The point of Example 1 is to establish the following conjecture for the class community and prove the conjecture.

CONJECTURE: Let A be a point on a circle, let \overrightarrow{AB} be a tangent ray to the circle, and let C be a point on the circle such that \overrightarrow{AC} is a secant to the circle. If $a = m\angle BAC$ and b is the angle measure of the arc intercepted by $\angle BAC$, then $a = \frac{1}{2}b$.

The opening exercise establishes empirical evidence toward the conjecture and helps students determine whether their reasoning on the homework may have had flaws; it can be used to see how well students understand the diagram and to review how to measure arcs.

Students will need a protractor and a ruler.

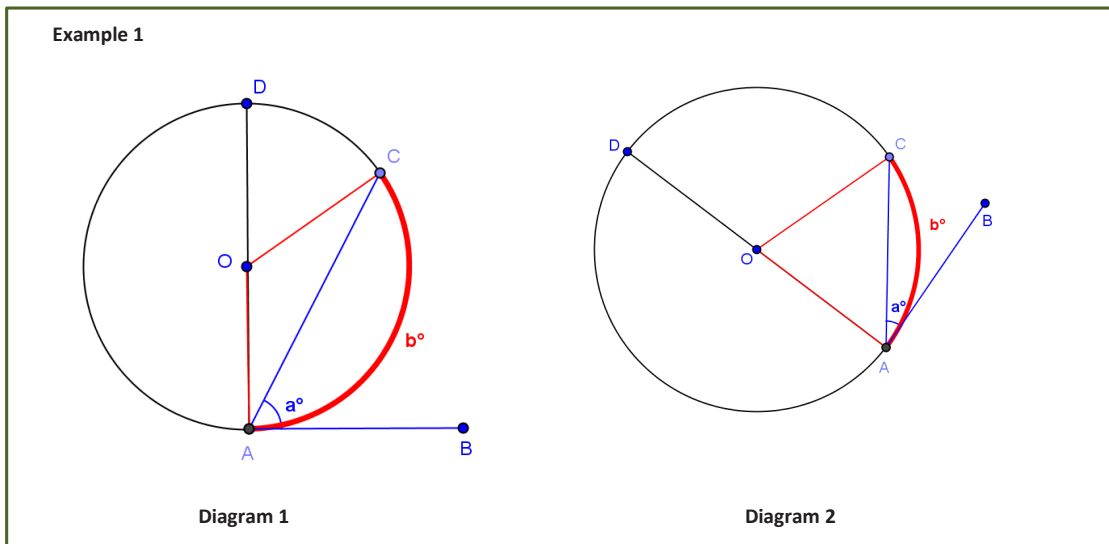

Examine the diagrams shown. Develop a conjecture about the relationship between a and b .

$$a = \frac{1}{2}b$$

Test your conjecture by using a protractor to measure a and b .

	a	b
Diagram 1		
Diagram 2		

Do your measurements confirm the relationship you found in your homework?

If needed, revise your conjecture about the relationship between a and b :

Now test your conjecture further using the circle below.

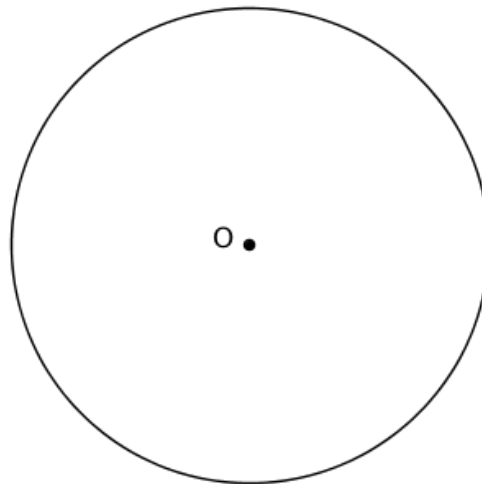

a	b

- What did you find about the relationship between a and b ?
 - $a = \frac{1}{2}b$. An angle inscribed between a tangent line and secant line is equal to half of the angle measure of its intercepted arc.

- How did you test your conjecture about this relationship?
 - *Look for evidence that students recognized that the angle should be formed by a secant intersecting a tangent at the point of tangency and that they knew to measure the arc by taking its central angle.*
- What conjecture did you come up with? Share with a neighbor.
 - *Let students discuss, and then state a version of the conjecture publically.*

Now, we will prove your conjecture, which is stated below as a theorem.

THE TANGENT-SECANT THEOREM: Let A be a point on a circle, let \overline{AB} be a tangent ray to the circle, and let C be a point on the circle such that \overline{AC} is a secant to the circle. If $a = m\angle BAC$ and b is the angle measure of the arc intercepted by $\angle BAC$, then $a = \frac{1}{2}b$.

Given circle A with tangent \overline{BG} , prove what we have just discovered using what you know about the properties of a circle and tangent and secant lines.

- a. Draw triangle ABC . What is the measure of $\angle BAC$? Explain.

b° The central angle is equal to the degree measure of the arc it intercepts.

- b. What is the measure of $\angle ABG$? Explain.

90° The radius is perpendicular to the tangent line at the point of tangency.

- c. Express the measure of the remaining two angles of triangle ABC in terms of " a " and explain.

The angles are congruent because the triangle is isosceles. Each angle has a measure of $(90 - a)^\circ$ since $m\angle ABC + m\angle CBG = 90^\circ$.

- d. What is the measure of $\angle BAC$ in terms of " a "? Show how you got the answer.

The sum of the angles of a triangle is 180° , so $90 - a - a + b = 180^\circ$. Therefore, $b = 2a$ or $a = \frac{1}{2}b$.

- e. Explain to your neighbor what we have just proven.

An inscribed angle formed by a secant and tangent line is half of the angle measure of the arc it intercepts.

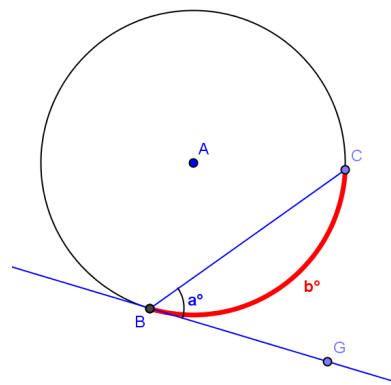

Example 2 (5 minutes)

We have shown that the inscribed angle theorem can be extended to the case when one of the angle’s rays is a tangent segment and the vertex is the point of tangency. Example 2 develops another theorem in the inscribed angle theorem’s family: the angle formed by the intersection of the tangent line and a chord of the circle on the circle and the inscribed angle of the same arc. This example is best modeled with dynamic Geometry software. Alternatively, the teacher may ask students to create a series of sketches that show point E moving towards point A .

THEOREM: Suppose \overline{AB} is a chord of circle C , and \overline{AD} is a tangent segment to the circle at point A . If E is any point other than A or B in the arc of C on the opposite side of \overline{AB} from D , then $m\angle BEA = m\angle BAD$.

- Draw a circle and label it C .
 - Students draw circle C .
- Draw a chord \overline{AB} .
 - Students draw chord AB .
- Construct a segment tangent to the circle through point A , and label it \overline{AD} .
 - Students construct tangent segment \overline{AD} .
- Now draw and label point E that is between A and B but on the other side of chord \overline{AB} from D .
 - Students draw point E .
- Rotate point E on the circle towards point A . What happens to \overline{EB} ?
 - \overline{EB} moves closer and closer to lying on top of \overline{AB} as E gets closer and closer to A .
- What happens to \overline{EA} ?
 - \overline{EA} moves closer and closer to lying on top of \overline{AD} .
- What happens to $\angle BEA$?
 - $\angle BEA$ moves closer and closer to lying on top of $\angle BAD$.
- Does the $m\angle BEA$ change as it rotates?
 - No, it remains the same because the intercepted arc length does not change.
- Explain how these facts show that $m\angle BEA = m\angle BAD$?
 - The measure of angle $\angle BEA$ does not change. The segments are just rotated, but the angle measure is conserved.

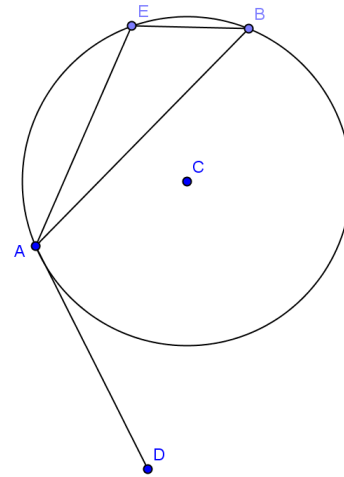

Exercises (12 minutes)

Students should work on the exercises individually and then compare answers with a neighbor. Walk around the room, and use this as a quick informal assessment.

Exercises

Find x , y , a , b , and/or c .

1.

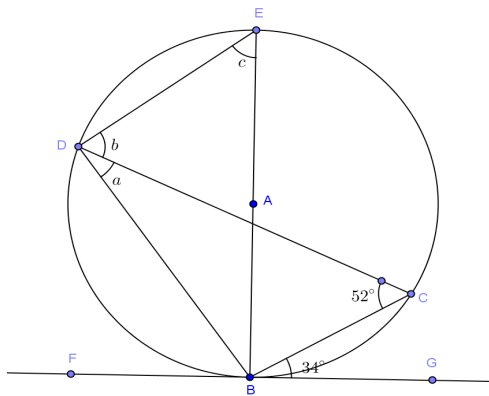

$a = 34^\circ, b = 56^\circ, c = 52^\circ$

2.

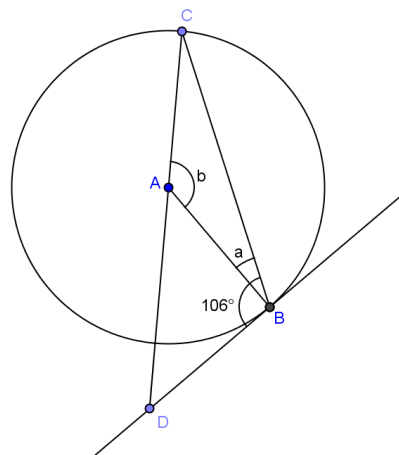

$a = 16^\circ, b = 148^\circ$

3.

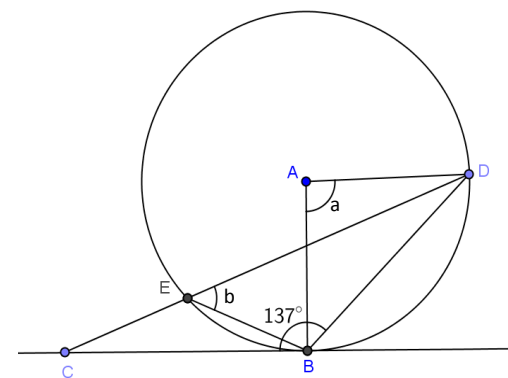

$a = 86^\circ, b = 43^\circ$

4.

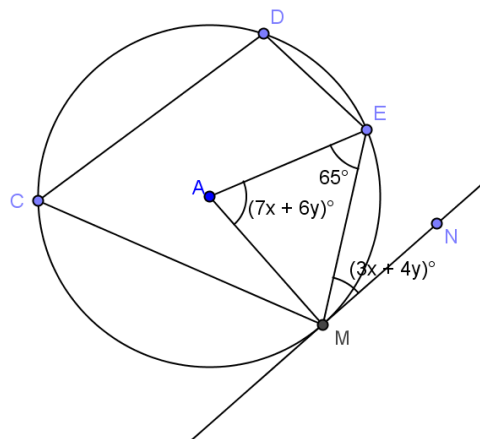

$x = 5, y = 2.5$

MP.1

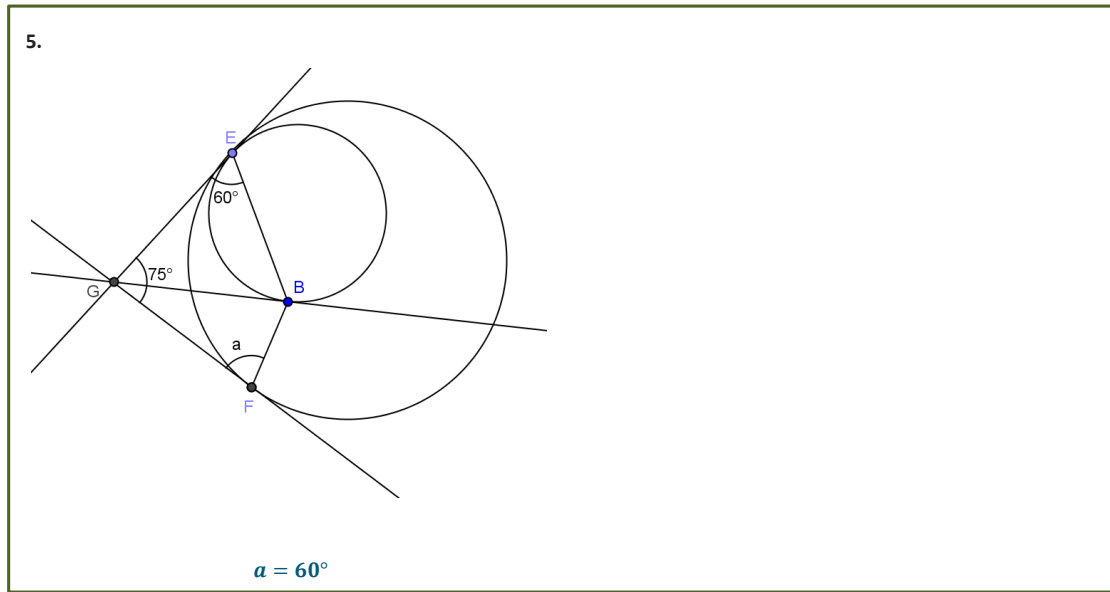

MP.1

Closing (3 minutes)

Have students do a 30-second quick write of everything that we have studied in Topic C on tangent lines to circles and their segment and angle relationships. Bring the class back together and share, allowing students to add to their list.

- What have we learned about tangent lines to circles and their segment and angle relationships?
 - A tangent line intersects a circle at exactly one point (and is in the same plane).
 - The point where the tangent line intersects a circle is called a point of tangency. The tangent line is perpendicular to a radius whose end point is the point of tangency.
 - The two tangent segments to a circle from an exterior point are congruent.
 - The measure of an angle formed by a tangent segment and a chord is $\frac{1}{2}$ the angle measure of its intercepted arc.
 - If an inscribed angle intercepts the same arc as an angle formed by a tangent segment and a chord, then the two angles are congruent.

Lesson Summary

THEOREMS:

- **CONJECTURE:** Let A be a point on a circle, let \overline{AB} be a tangent ray to the circle, and let C be a point on the circle such that \overline{AC} is a secant to the circle. If $a = m\angle BAC$ and b is the angle measure of the arc intercepted by $\angle BAC$, then $a = \frac{1}{2}b$.
- **THE TANGENT-SECANT THEOREM:** Let A be a point on a circle, let \overline{AB} be a tangent ray to the circle, and let C be a point on the circle such that \overline{AC} is a secant to the circle. If $a = m\angle BAC$ and b is the angle measure of the arc intercepted by $\angle BAC$, then $a = \frac{1}{2}b$.
- Suppose \overline{AB} is a chord of circle C , and \overline{AD} is a tangent segment to the circle at point A . If E is any point other than A or B in the arc of C on the opposite side of \overline{AB} from D , then $m\angle BEA = m\angle BAD$.

Exit Ticket (5 minutes)

Name _____

Date _____

Lesson 13: The Inscribed Angle Alternate a Tangent Angle

Exit Ticket

Find a , b , and c .

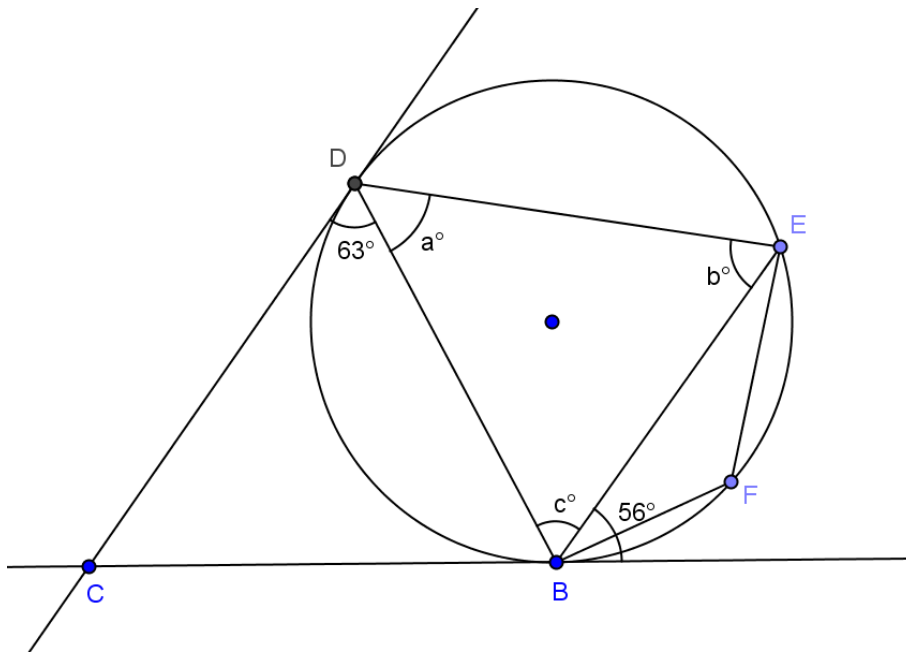

Exit Ticket Sample Solutions

Find a , b , and c .
 $a = 56^\circ$, $b = 63^\circ$, $c = 61^\circ$

Problem Set Sample Solutions

The first 6 problems are easy entry problems and are meant to help students struggling with the concepts of this lesson. They show the same problems with varying degrees of difficulty. Problems 7–11 are more challenging. Assign problems based on student ability.

In Problems 1–9, solve for a , b , and/or c .

1.

$a = 67^\circ$

2.

$a = 67^\circ$

3.

$a = 67^\circ$

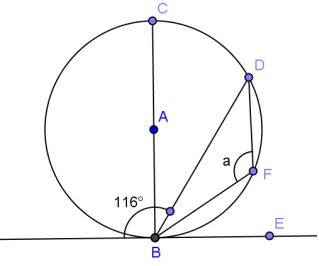
4.  $a = 116^\circ$

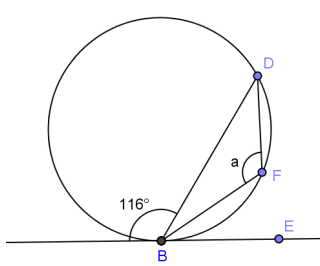
5.  $a = 116^\circ$

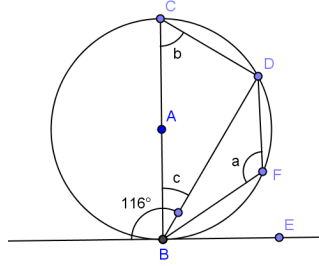
6.  $a = 116^\circ, b = 64^\circ, c = 26^\circ$

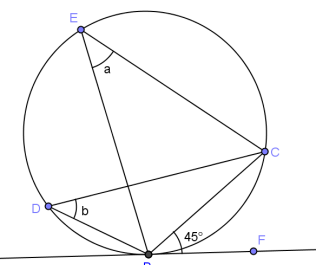
7.  $a = 45^\circ, b = 45^\circ$

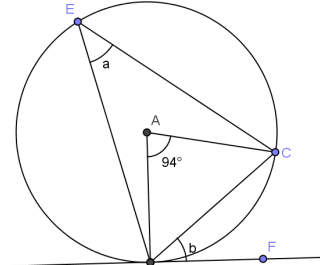
8.  $a = 47^\circ, b = 47^\circ$

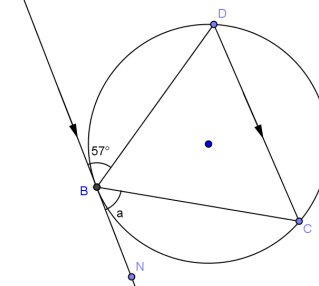
9.  $a = 57^\circ$

10. \overline{BH} is tangent to circle A. \overline{DF} is a diameter. Find

- $m\angle BCD$
 50°
- $m\angle BAF$
 80°
- $m\angle BDA$
 40°
- $m\angle FBH$
 40°
- $m\angle BGF$
 98°

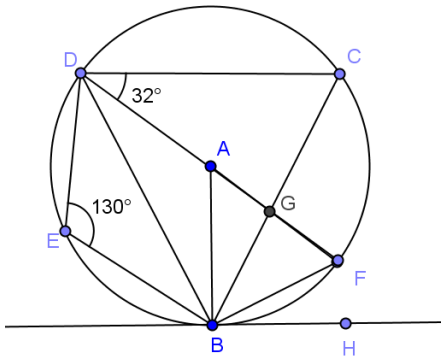

11. \overline{BG} is tangent to circle A. \overline{BE} is a diameter. Prove: (i) $f = a$ and (ii) $d = c$

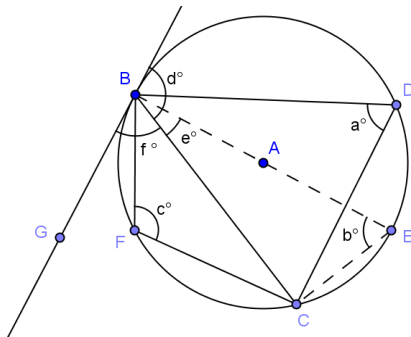

- (i) $m\angle EBG = 90^\circ$ *tangent perpendicular to radius*
 $f = 90 - e$ *sum of angles*
 $m\angle ECB = 90^\circ$ *angle inscribed in semi-circle*
 In $\triangle ECB$,
 $b + 90 + e = 180$ *sum of angles of a triangle*
 $b = 90 - e$
 $a = b$ *angles inscribed in same arc congruent*
 $a = f$ *substitution*
- (ii) $a + c = 180$ *inscribed in opposite arcs*
 $a = f$ *inscribed in same arc*
 $f + d = 180$ *linear pairs form supplementary angles*
 $c + f = f + d$ *substitution*
 $c = d$



Lesson 14: Secant Lines; Secant Lines That Meet Inside a Circle

Student Outcomes

- Students understand that an angle whose vertex lies in the interior of a circle intersects the circle in two points and that the edges of the angles are contained within two secant lines of the circle.
- Students discover that the measure of an angle whose vertex lies in the interior of a circle is equal to half the sum of the angle measures of the arcs intercepted by it and its vertical angle.

Lesson Notes

Lesson 14 begins the study of secant lines. The study actually began in Lessons 4–6 with inscribed angles, but we did not call the lines secant then. Therefore, students have already studied the first case, lines that intersect on the circle. In this lesson, students study the second case, secants intersecting inside the circle. The third case, secants intersecting outside the circle, will be introduced in Lesson 15.

Classwork

Opening Exercise (5 minutes)

This exercise reviews the relationship between tangent lines and inscribed angles, preparing students for our work in Lesson 14. Have students work on this exercise individually and then compare answers with a neighbor. Finish with a class discussion.

Opening Exercise

\overline{DB} is tangent to the circle as shown.

- a. Find the values of a and b .

$$a = 13, b = 80$$

- b. Is \overline{CB} a diameter of the circle? Explain.

No, if \overline{CB} was a diameter, then $m\angle CEB$ would be 90° .

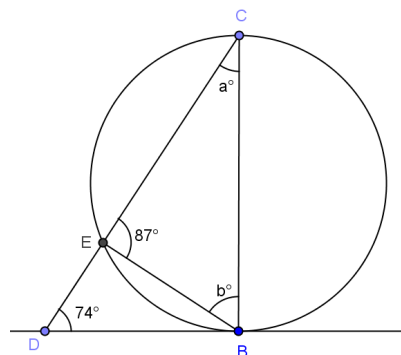

Discussion (10 minutes)

In this discussion, we remind students of the definitions of tangent and secant lines and then have students draw circles and lines to see the different possibilities of where tangent and secant lines can intersect with respect to a circle. Every student should draw the sketches called for and then, as a class, classify the sketches and talk about why the classifications were chosen.

- Draw a circle and a line that intersects the circle.
 - *Students draw a circle and a line.*
- Have the students tape their sketches to the board.
- Let's group together the diagrams that are alike.
 - *Students should notice that some circles have lines that intersect the circle twice and others only touch the circle once, and students should separate them accordingly.*

MP.7

Scaffolding:

- Post the theorem definitions from previous lessons in this module on the board so that students can easily review them if necessary. Add definitions and theorems as they are studied.

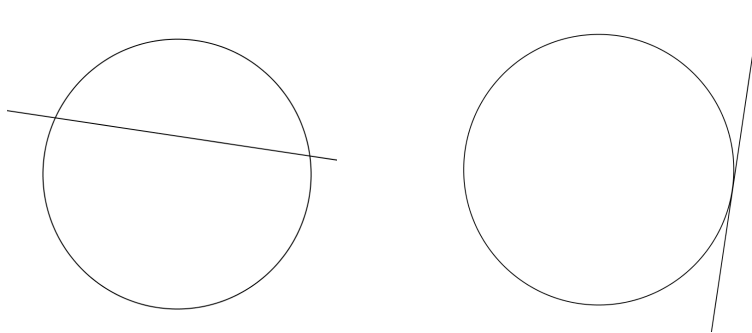

- Explain how the groups are different.
 - *A line and a circle in the same plane that intersect can intersect in one or two points.*
- Does anyone know what we call each of these lines?
 - *A line that intersects a circle at exactly two points is called a secant line.*
 - *A line in the same plane that intersects a circle at exactly one point is called a tangent line.*
- Label each group of diagrams as “secant lines” and “tangent lines.” Then, as a class, have students write their own definition of each.
- **SECANT LINE:** *A secant line to a circle is a line that intersects a circle in exactly two points.*
- **TANGENT LINE:** *A tangent line to a circle is a line in the same plane that intersects the circle in one and only one point.*
- This lesson focuses on secant lines. We studied tangent lines in Lessons 11–13.
- Starting with a new piece of paper, draw a circle and draw two secant lines. (Check to make sure that students are drawing two lines that each intersect the circle twice. This is an informal assessment of their understanding of the definition of a secant line.)
 - *Students draw a circle and two secant lines.*
- Again, have students tape their sketches to the board.
- Let's group together the diagrams that are alike.

Students should notice that some lines intersect outside of the circle, others inside the circle, others on the circle, and others are parallel and don't intersect. Teachers may want to have a case of each prepared ahead of time in case all are not created by the students.

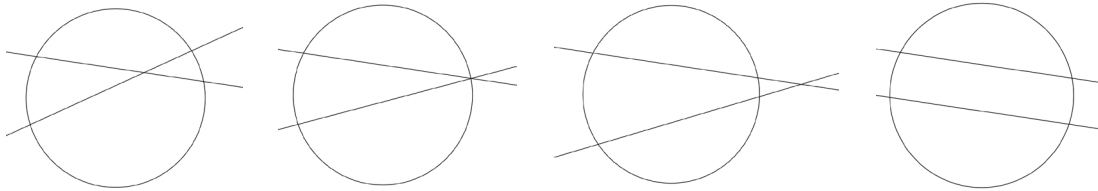

- We have four groups. Explain the differences between the groups.
 - *Some lines intersect outside of the circle, others inside the circle, others on the circle, and others are parallel and don't intersect.*
- Label each group as “intersect outside the circle,” “intersect inside the circle,” “intersect on the circle,” “intersect on the circle,” and “parallel.”
- Show students that the angles formed by intersecting secant lines have edges that are contained in the secant lines.
- Today we will talk about three of the cases of secant lines of a circle and the angles that are formed at the point of intersection.

Exercises 1–2 (5 minutes)

Exercises 1–2 deal with secant lines that are parallel and secant lines that intersect on the circle (Lessons 4–6). When exercises are presented, students should realize that we already know how to determine the angles in these cases.

Exercises 1–2

1. In circle P , \overline{PO} is a radius, and $m\widehat{MO} = 142^\circ$. Find $m\angle MOP$, and explain how you know.

$m\angle MOP = 19^\circ$

Since \overline{PO} is a radius and extends to a diameter, the measure of the arc intercepted by the diameter is 180° . $m\widehat{MO} = 142^\circ$, so the arc intercepted by $\angle MOP$ is $180^\circ - 142^\circ = 38^\circ$. $\angle MOP$ is inscribed in this arc, so its measure is half the degree measure of the arc or $\frac{1}{2}(38^\circ) = 19^\circ$.

2. In the circle shown, $m\widehat{CE} = 55^\circ$. Find $m\angle DEF$ and $m\widehat{EG}$. Explain your answer.

$m\angle DEF = 27.5^\circ$

$m\widehat{EG} = 55^\circ$

$m\widehat{CE} = m\widehat{DF}$ and $m\widehat{DF} = m\widehat{EG}$ because arcs between parallel lines are congruent.

By substitution, $m\widehat{EG} = 55^\circ$.

$m\widehat{DF} = 55^\circ$ so $m\angle DEF = \frac{1}{2}(55^\circ) = 27.5^\circ$ because it is inscribed in a 55° arc.

Example 1 (12 minutes)

In this example, students are introduced for the first time to secant lines that intersect inside a circle.

Example 1

a. Find x . Justify your answer.

80°. If you draw $\triangle BDG$, $m\angle DBG = 20^\circ$, and $m\angle BDG = 60^\circ$ because they are half of the measures of their inscribed arcs, that means $m\angle BGD = 100^\circ$ because the sums of the angles of a triangle total 180° . $\angle DGB$ and $\angle BGE$ are supplementary, so $m\angle BGE = 80^\circ$.

MP.7

- What do you think the measure of $\angle BGE$ is?
 - Responses will vary and many will just guess.
 - This is not an inscribed angle or a central angle and the chords are not congruent, so students won't actually know the answer. That is what we want them to realize – they don't know.
- Is there an auxiliary segment you could draw that would help determine the measure of $\angle BGE$?
 - Draw chord \overline{BD} .
- Can you determine any of the angles in $\triangle BDG$? Explain.
 - Yes, all of them. $m\angle DBC = 20^\circ$ because it is half of the degree measure of the intercepted arc, which is 40° . $m\angle BDE = 60^\circ$ because it is half of the degree measure of the intercepted arc, which is 120° . $m\angle DGB = 100^\circ$ because the sum of the angles of a triangle are 180° .
- Does this help us determine x ?
 - Yes, $\angle DGB$ and $\angle BGE$ are supplementary, so their sum is 180° . That means $m\angle BGE = 80^\circ$.
- The angle $\angle BGE$ in part (a) above is often called a *secant angle* because its sides are contained in two secants of the circle such that each side intersects the circle in at least one point other than the angle's vertex.
- Is the vertical angle $\angle DGC$ also a secant angle?
 - Yes, rays \overrightarrow{GD} and \overrightarrow{GC} intersect the circle at points D and C respectively.

Let's try another problem. Have students work in groups to go through the same process to determine x .

b. Find x .

31.5

Scaffolding:

- Advanced students should determine x and the general result independently.
- Use scaffolded questions with the whole class or a targeted small group.

- Can we determine a general result?
- What equation would represent the result we are looking to prove?
 - $x = \frac{a+b}{2}$
- Draw \overline{BD} .
 - *Students draw chord BD.*
- What are the measures of the angles in $\triangle BDG$?
 - $m\angle GBD = \frac{1}{2}a$
 - $m\angle BDG = \frac{1}{2}b$
 - $m\angle BGD = 180 - \frac{1}{2}a - \frac{1}{2}b$
- What is x ?
 - $x = 180 - (180 - \frac{1}{2}a - \frac{1}{2}b)$
- Simplify that.
 - $x = \frac{1}{2}a + \frac{1}{2}b = \frac{a+b}{2}$
- What have we just determined? Explain this to your neighbor.
 - *The measure of an angle whose vertex lies in the interior of a circle is equal to half the sum of the angle measures of the arcs intercepted by it and its vertical angle.*
- Does this formula also apply to secant lines that intersect on the circle (an inscribed angle) as in Exercise 1?
- Have students look at Exercise 1 again.
- What are the angle measures of the two intercepted arcs?
 - *There is only one intercepted arc and its measure is 38° .*
- The vertical angle doesn't intercept an arc since its vertex lies on the circle. Suppose for a minute, however, that the "arc" is that vertex point. What would the angle measure of that "arc" be?
 - *It would have a measure of 0° .*
- Does our general formula still work using 0° for the measure or the "arc" given by the vertical angle?
 - $\frac{38+0}{2} = 19^\circ$. *It does work.*
- Explain this to your neighbor.
 - *The measure of an inscribed angle is a special case of the general formula when suitably interpreted.*

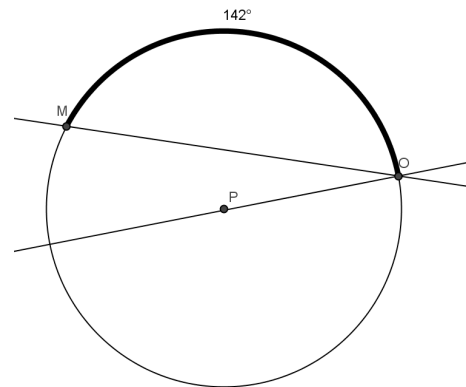
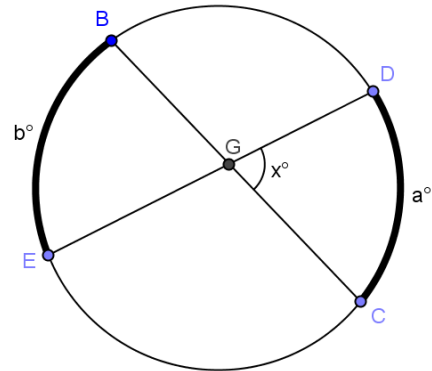

We can state the results of part (b) of this example as the following theorem:

SECANT ANGLE THEOREM: INTERIOR CASE. The measure of an angle whose vertex lies in the interior of a circle is equal to half the sum of the angle measures of the arcs intercepted by it and its vertical angle.

Exercises 3–7 (5 minutes)

The first three exercises are straight forward, and all students should be able to use the formula found in this lesson to solve. The final problem is a little more challenging. Assign some students only Exercises 3–5 and others 5–7. Have students complete these individually and then compare with a neighbor. Walk around the room, and use this as an informal assessment of student understanding.

In Exercises 3–5, find x and y .

3.

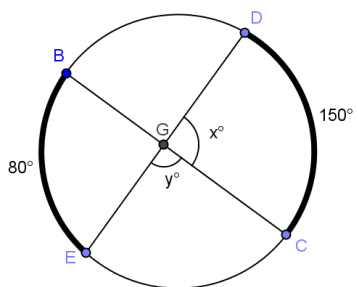

$x = 115, y = 65$

4.

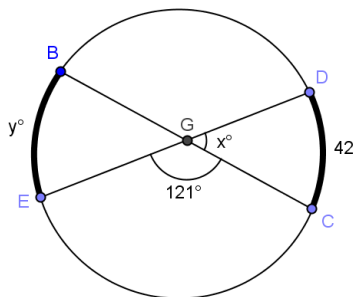

$x = 59, y = 76$

5.

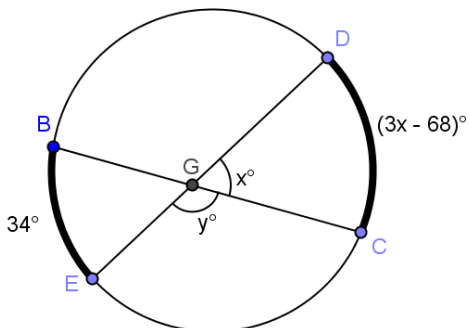

$x = 34, y = 146$

6. In circle, \overline{BC} is a diameter. Find x and y .

$x = 24, y = 53$

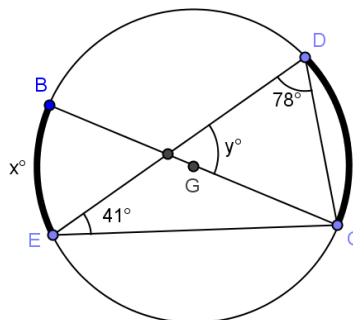

7. In the circle shown, \overline{BC} is a diameter. $DC:BE = 2:1$. Prove $y = 180 - \frac{3}{2}x$ using a two-column proof.

\overline{BC} is a diameter of circle A	Given
$m\angle DBC = x$	Given
$m\widehat{DC} = 2x$	Arc is double angle measure of inscribed angle
$m\widehat{BE} = x$	$DC:BE = 2:1$
$m\widehat{BDC} = m\widehat{BEC} = 180^\circ$	Semi-circle measures 180°
$m\widehat{DB} = 180 - 2x$	Arc addition
$m\widehat{EC} = 180 - x$	Arc addition
$m\angle BFD = \frac{1}{2}(180 - 2x + 180 - x)$	
Measure of angle whose vertex lies in a circle is half the angle measures of arcs intercepted by it and its vertical angles.	
$y = 180 - \frac{3}{2}x$	Substitution and simplification.

Closing (3 minutes)

Project the circles below on the board, and have a class discussion with the following questions.

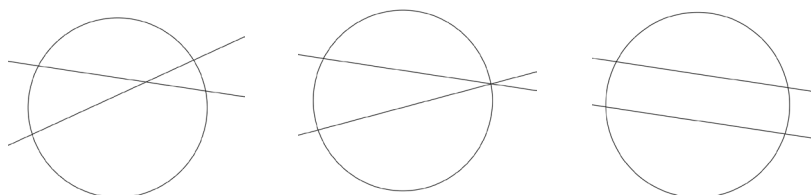

- What types of lines are drawn through the three circles?
 - Secant lines
- Explain the relationship between the angles formed by the secant lines and the intercepted arcs in the first two circles.
 - The first circle has angles with a vertex inside the circle. The measure of an angle whose vertex lies in the interior of a circle is equal to half the sum of the angle measures of the arcs intercepted by it and its vertical angle.
 - The second circle has an angle on the vertex, an inscribed angle. Its measure is half the angle measure of its intercepted arc.
- How is the third circle different?
 - The lines are parallel, and no angles are formed. The arcs are congruent between the lines.

Lesson Summary

THEOREMS:

SECANT ANGLE THEOREM: INTERIOR CASE. The measure of an angle whose vertex lies in the interior of a circle is equal to half the sum of the angle measures of the arcs intercepted by it and its vertical angle.

Relevant Vocabulary

- **TANGENT TO A CIRCLE:** A *tangent line to a circle* is a line in the same plane that intersects the circle in one and only one point. This point is called the *point of tangency*.
- **TANGENT SEGMENT/RAY:** A segment is a *tangent segment to a circle* if the line that contains it is tangent to the circle and one of the end points of the segment is a point of tangency. A ray is called a *tangent ray to a circle* if the line that contains it is tangent to the circle and the vertex of the ray is the point of tangency.
- **SECANT TO A CIRCLE:** A *secant line to a circle* is a line that intersects a circle in exactly two points.

Exit Ticket (5 minutes)

Name _____

Date _____

Lesson 14: Secant Lines; Secant Lines That Meet Inside a Circle

Exit Ticket

- Lowell says that $m\angle DFC = \frac{1}{2}(123) = 61.5^\circ$ because it is half of the intercepted arc. Sandra says that you can't determine the measure of $\angle DFC$ because you don't have enough information. Who is correct and why?

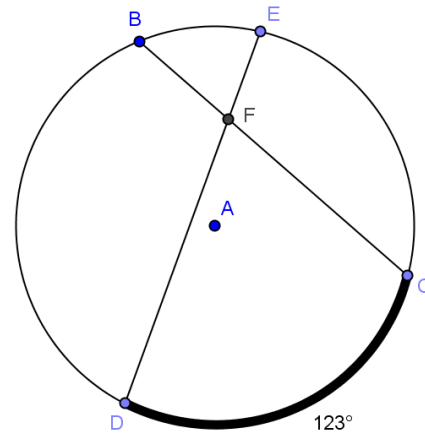

- If $m\angle EFC = 99^\circ$, find and explain how you determined your answer.
 - $m\angle BFE$
 - $m\widehat{BE}$

Exit Ticket Sample Solutions

1. Lowell says that $m\angle DFC = \frac{1}{2}(123) = 61.5^\circ$ because it is half of the intercepted arc. Sandra says that you can't determine the measure of $\angle DFC$ because you don't have enough information. Who is correct and why?

Sandra is correct. We would need more information to determine the answer. Lowell is incorrect because $\angle DFC$ is not a central angle.

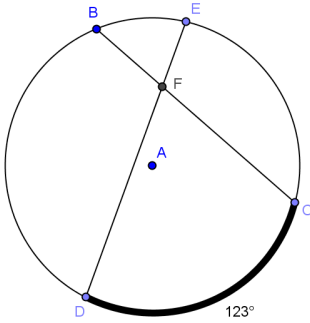

2. If $m\angle EFC = 99^\circ$, find and explain how you determined your answer.

a. $m\angle BFE$
 81° , $m\angle EFC + m\angle BFE = 180^\circ$ (supplementary angles), so $180 - 99 = m\angle BFE$.

b. $m\widehat{BE}$
 39° , $81 = \frac{1}{2}(y + 123)$ using formula for an angle with vertex inside a circle.

Problem Set Sample Solutions

Problems 1–4 are more straightforward. The other problems are more challenging and could be given as a student choice or specific problems assigned to different students.

In Problems 1–4, find x .

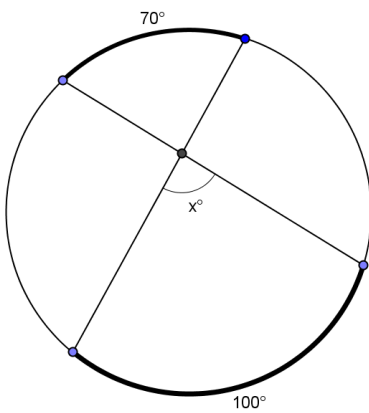
1.  $x = 85$

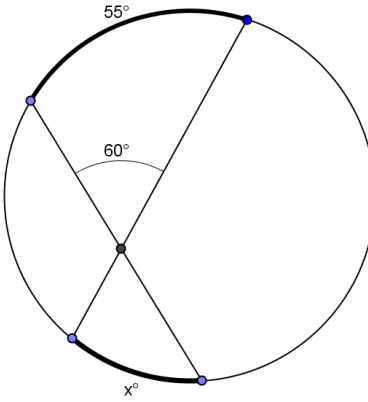
2.  $x = 65$

3.

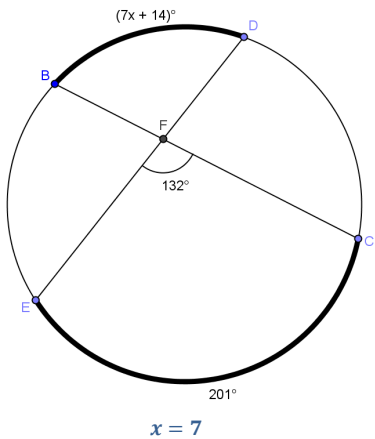

4.

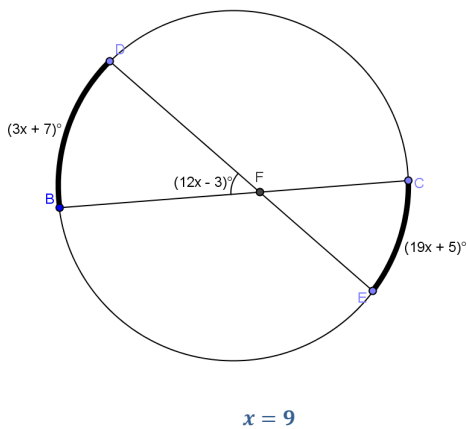

5. Find $x(m\widehat{CE})$ and $y(m\widehat{DG})$.

$x = 70, y = 100$

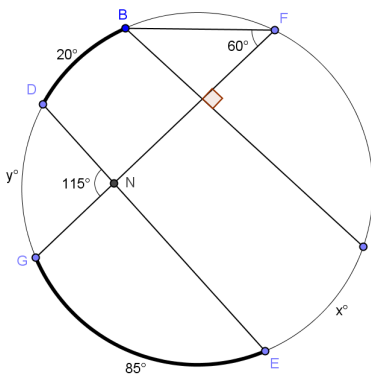

6. Find the ratio of $m\widehat{EFC} : m\widehat{DGB}$.

3:4

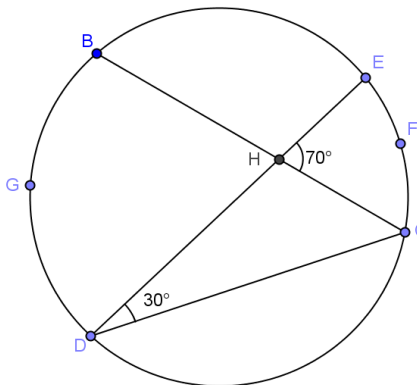

7. \overline{BC} is a diameter of circle A .

$x = 108$

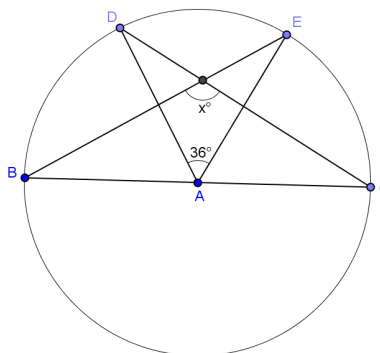

8. Show that the general formula we discovered in Example 1 also works for central angles. (Hint: Extend the radii to form 2 diameters, and use relationships between central angles and arc measure.)

Extend the radii to form two diameters.

Let the measure of the central angle = x° .

The measure $m\widehat{BC} = x^\circ$ because the angle measure of the arc intercepted by a central angle is equal to the measure of the central angle.

The measure of the vertical angle is also x° because vertical angles are congruent.

The angle of the arc intercepted by the vertical angle is also x° .

The measure of the central angle is half the sum of angle measures of the arcs intercepted by the central angle and its vertical angle ($x = \frac{1}{2}(x + x)$).

This formula also works for central angles.

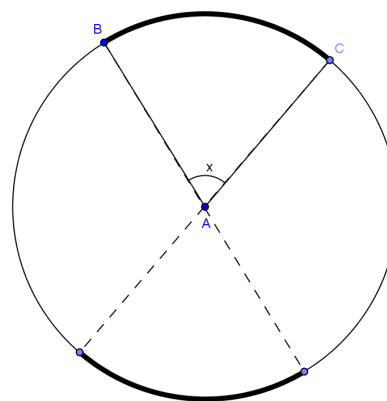
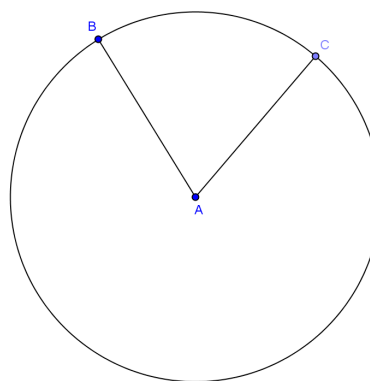



Lesson 15: Secant Angle Theorem, Exterior Case

Student Outcomes

- Students find the measures of angle/arcs and chords in figures that include two secant lines meeting outside a circle, where the measures must be inferred from other data.

Lesson Notes

The Opening Exercise reviews and solidifies the concept of secants intersecting inside of the circle and the relationships between the angles and the subtended arcs. Students then extend that knowledge in the remaining examples. Example 1 looks at a tangent and secant intersecting on the circle. Example 2 moves the point of intersection of two secant lines outside of the circle and continues to allow students to explore the angle/arc relationships.

Classwork

Opening Exercise (10 minutes)

This Opening Exercise reviews Lesson 14, secant lines that intersect inside circles. Students must have a firm understanding of this concept to extend this knowledge to secants intersecting outside the circle. Students need a protractor for this exercise. Have students initially work individually and then compare answers and work with a partner. Use this as a way to informally assess student understanding.

Opening Exercise

1. Shown below are circles with two intersecting secant chords.

Measure a , b , and c in the two diagrams. Make a conjecture about the relationship between them.

a	b	c
60°	80°	40°
130°	100°	160°

Scaffolding:

- Post pictures of the different types of angle and arc relationships that we have studied so far with the associated formulas to help students.

CONJECTURE about the relationship between a , b , and c :

$a = \frac{b+c}{2}$. *The measure a is the average of b and c .*

2. We will prove the following.

SECANT ANGLE THEOREM: INTERIOR CASE. The measure of an angle whose vertex lies in the interior of a circle is equal to half the sum of the angle measures of the arcs intercepted by it and its vertical angle.

We can interpret this statement in terms of the diagram below. Let b and c be the angle measures of the arcs intercepted by the angles $\angle SAQ$ and $\angle PAR$. Then measure a is the average of b and c ; that is, $a = \frac{b+c}{2}$.

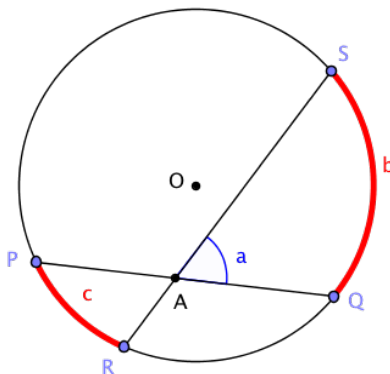

a. Find as many pairs of congruent angles as you can in the diagram below. Express the measures of the angles in terms of b and c whenever possible.

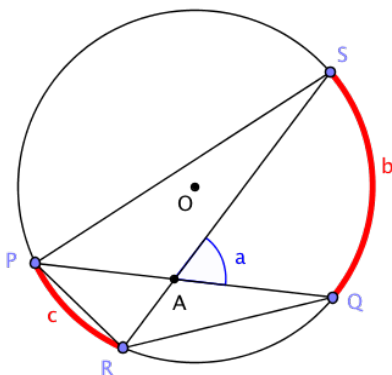

$$m\angle PQR = m\angle PSR = \frac{1}{2}c$$

$$m\angle QPS = m\angle QRS = \frac{1}{2}b$$

b. Which triangles in the diagram are similar? Explain how you know.

$\triangle PSA \sim \triangle RQA$. *All angles in each pair have the same measure.*

c. See if you can use one of the triangles to prove the secant angle theorem: interior case. (Hint: Use the exterior angle theorem.)

By the exterior angle theorem, $a = m\angle PQR + m\angle QRS$. We can conclude $a = \frac{1}{2}(b + c)$.

MP.3

Turn to your neighbor and summarize what we've learned so far in this exercise.

Example 1 (10 minutes)

We have shown that the inscribed angle theorem can be extended to the case when one of the angle's rays is a tangent segment and the vertex is the point of tangency. Example 1 develops another theorem in the inscribed angle theorem's family, the secant angle theorem: exterior case.

THEOREM (SECANT ANGLE THEOREM: EXTERIOR CASE). *The measure of an angle whose vertex lies in the exterior of the circle, and each of whose sides intersect the circle in two points, is equal to half the difference of the angle measures of its larger and smaller intercepted arcs.*

Scaffolding:

- For advanced learners, this example could be given as individual or pair work without leading questions.
- Use scaffolded questions with a targeted small group.
- For example: Look at the table that you created. Do you see a pattern between the sum of b and c and the value of a ?

Example 1

Shown below are two circles with two secant chords intersecting outside the circle.

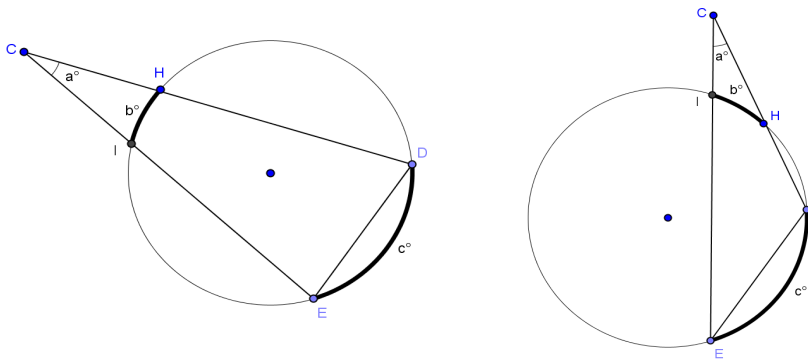

Measure a , b , and c . Make a conjecture about the relationship between them.

a	b	c

Conjecture about the relationship between a , b , and c :

Test your conjecture with another diagram.

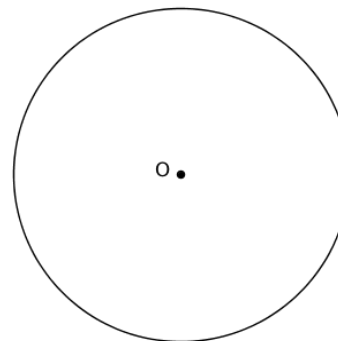

Example 2 (7 minutes)

In this example, we will rotate the secant lines one at a time until one and then both are tangent to the circle. This should be easy for students to see but can be shown with dynamic geometry software.

- Let's go back to our circle with two secant lines intersecting in the exterior of the circle (show circle at right).
- Remind me how I would find the measure of angle C .
 - *Half the difference between the longer intercepted arc and the shorter intercepted arc.*
 - $\frac{1}{2}(m\widehat{DE} - m\widehat{FG})$
- Rotate one of the secant segments so that it becomes tangent to the circle (show circle at right).
- Can we apply the same formula?
 - *Answers will vary, but the answer is yes.*
- What is the longer intercepted arc? The shorter intercepted arc?
 - *The longer arc is \widehat{DE} . The shorter arc is \widehat{DG} .*
- So do you think we can apply the formula? Write the formula.
 - *Yes. $\frac{1}{2}(m\widehat{DE} - m\widehat{DG})$*
- Why is it not identical to the first formula?
 - *Point D is an endpoint that separates the two arcs.*
- Now rotate the other secant line so that it is tangent to the circle. (Show circle at right).
- Does our formula still apply?
 - *Answers will vary, but the answer is yes.*
- What is the longer intercepted arc? The shorter intercepted arc?
 - *The longer arc is \widehat{DE} . The shorter arc is \widehat{ED} .*
- How can they be the same?
 - *They aren't. We need to add a point in between so that we can show they are two different arcs.*
- So what is the longer intercepted arc? The shorter intercepted arc?
 - *The longer arc is \widehat{DHE} . The shorter arc is \widehat{ED} .*
- So do you think we can apply the formula? Write the formula.
 - *Yes. $\frac{1}{2}(m\widehat{DHE} - m\widehat{ED})$.*

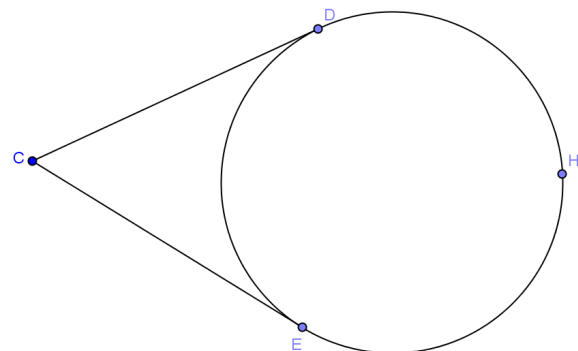
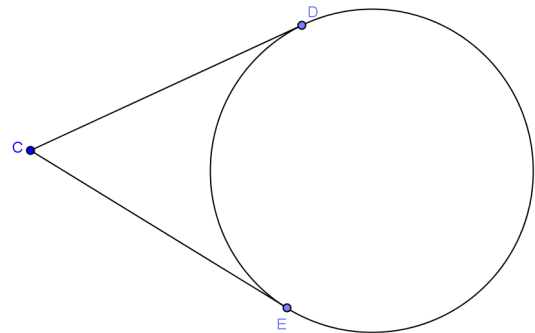
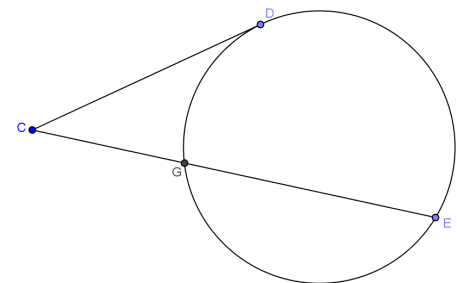
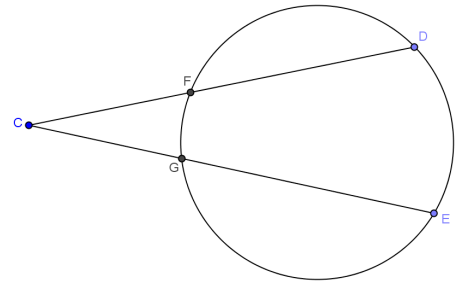

- Why is this formula different from the first two?
 - Points D and E are the endpoints that separate the two arcs.

Turn to your neighbor and summarize what you have learned in this exercise.

Exercises (8 minutes)

Have students work on the exercises individually and check their answers with a neighbor. Use this as an informal assessment and clear up any misconceptions. Have students present problems to the class as a wrap-up.

Exercises
Find x , y , and/or z .

1.

$x = 28$

2.

$x = 72$

3.

$x = 35$

4.

$x = 66, y = 57, z = 57$

Closing (5 minutes)

Have students complete the summary table, and then share as a class to make sure students understand concepts.

Lesson Summary:

We have just developed proofs for an entire family of theorems. Each theorem in this family deals with two shapes and how they overlap. The two shapes are two intersecting lines and a circle.

In this exercise, you'll summarize the different cases.

The Inscribed Angle Theorem and its Family of Theorems

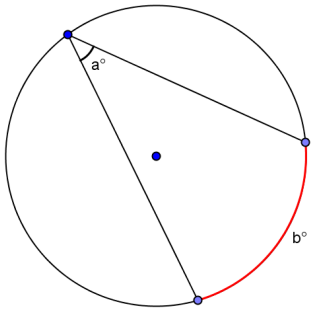
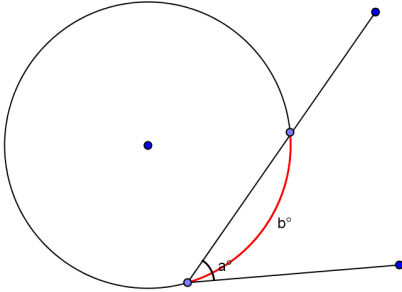
Diagram	How the two shapes overlap	Relationship between a , b , c , and d
 <p>(Inscribed Angle Theorem)</p>	<p><i>Intersection is on circle.</i></p>	<p>$a = \frac{1}{2}b$</p>
 <p>(Secant – Tangent)</p>	<p><i>Intersection is on the circle.</i></p>	<p>$a = \frac{1}{2}b$</p>

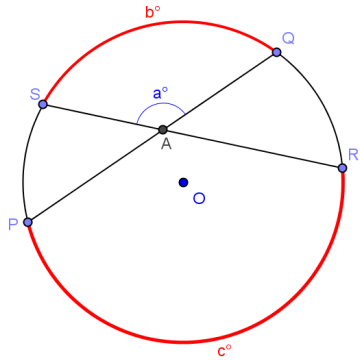
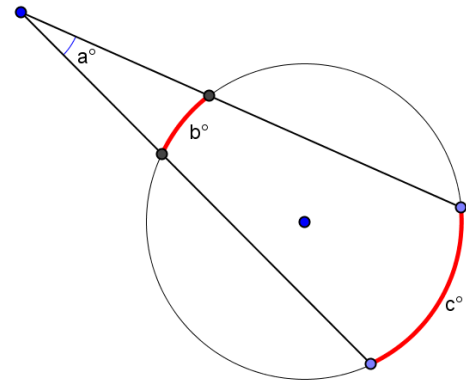
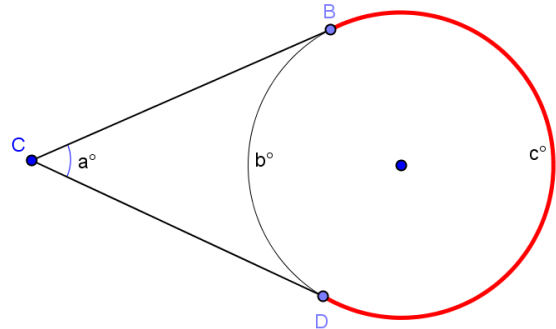
 <p>(Secant Angle Theorem: Interior)</p>	<p>Intersection is in the interior of the circle.</p>	$a = \frac{b + c}{2}$
 <p>(Secant Angle Theorem: Exterior)</p>	<p>Intersection is exterior to the circle.</p>	$a = \frac{c - b}{2}$
 <p>(Two Tangent Lines)</p>	<p>Intersection of two tangent lines to a circle.</p>	$a = \frac{c - b}{2}$

Lesson Summary

THEOREMS:

- **SECANT ANGLE THEOREM: INTERIOR CASE.** The measure of an angle whose vertex lies in the interior of a circle is equal to half the sum of the angle measures of the arcs intercepted by it and its vertical angle.
- **SECANT ANGLE THEOREM: EXTERIOR CASE.** The measure of an angle whose vertex lies in the exterior of the circle, and each of whose sides intersect the circle in two points, is equal to half the difference of the angle measures of its larger and smaller intercepted arcs.

Relevant Vocabulary

SECANT TO A CIRCLE: A *secant line to a circle* is a line that intersects a circle in exactly two points.

Exit Ticket (5 minutes)

Name _____

Date _____

Lesson 15: Secant Angle Theorem, Exterior Case

Exit Ticket

- Find x . Explain your answer.

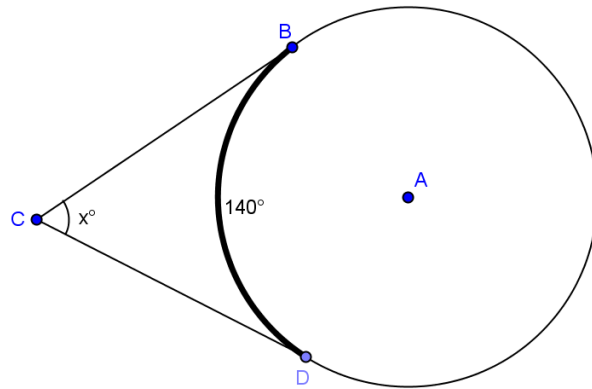

- Use the diagram to show that $m\widehat{DE} = y + x$ and $m\widehat{FG} = y - x$. Justify your work.

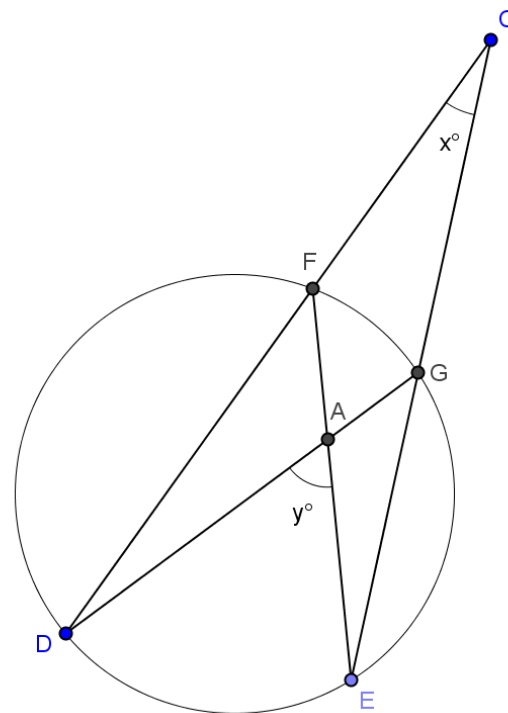

Exit Ticket Sample Solutions

1. Find x . Explain your answer.

$x = 40$. Major arc $m\widehat{BD} = 360 - 140 = 220$. $x = \frac{1}{2}(220 - 140) = 40$.

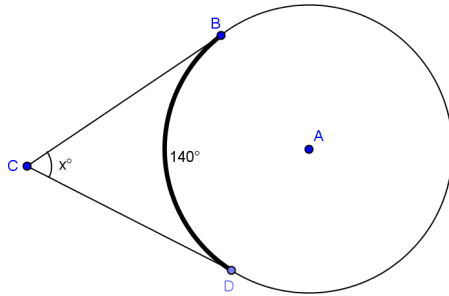

2. Use the diagram to show that $m\widehat{DE} = y + x$ and $m\widehat{FG} = y - x$. Justify your work.

$x = \frac{1}{2}(m\widehat{DE} - m\widehat{FG})$ or $2x = m\widehat{DE} - m\widehat{FG}$. Angle whose vertex lies exterior of circle is equal to half the difference of the angle measures of its larger and smaller intercepted arcs.

$y = \frac{1}{2}(m\widehat{DE} + m\widehat{FG})$ or $2y = m\widehat{DE} + m\widehat{FG}$. Angle whose vertex lies in a circle is equal to half the sum of the arcs intercepted by the angle and its vertical angle.

Adding the two equations gives $2x + 2y = 2m\widehat{DE}$ or $x + y = m\widehat{DE}$.

Subtracting the two equations gives $2y - 2x = 2m\widehat{FG}$ or $y - x = m\widehat{FG}$.

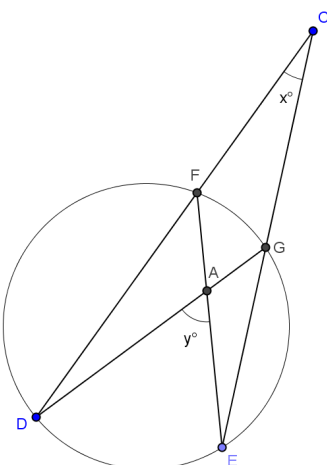

Problem Set Sample Solutions

1. Find x .

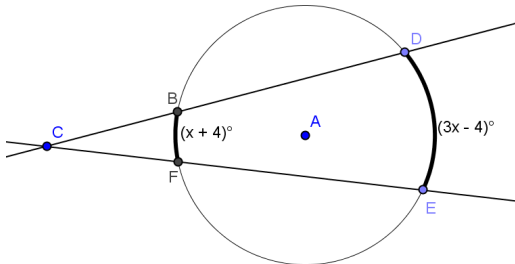

$x = 32$

2. Find $m\angle DFE$ and $m\angle DGB$.

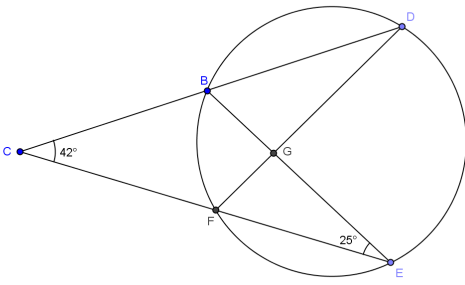

$m\angle DFE = 67^\circ, m\angle DGB = 88^\circ$

3. Find $m\angle ECD$, $m\angle DBE$, and $m\angle DEB$.

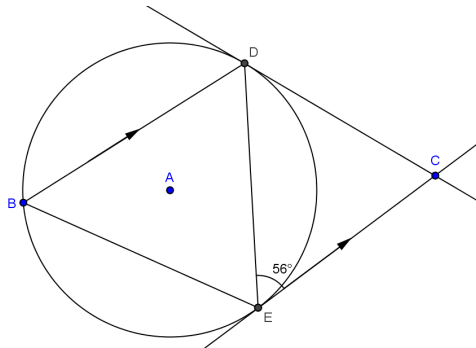

$m\angle ECD = 68^\circ, m\angle DBE = 56^\circ, m\angle DEB = 6^\circ$

4. Find $m\angle FGE$ and $m\angle FHE$.

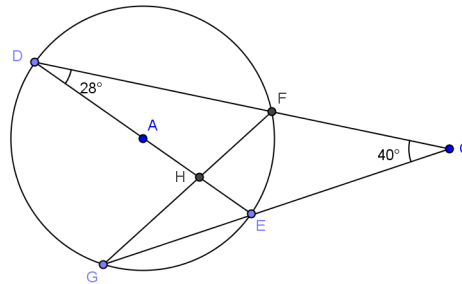

$m\angle FGE = 28^\circ, m\angle FHE = 9^\circ$

5. Find x and y .

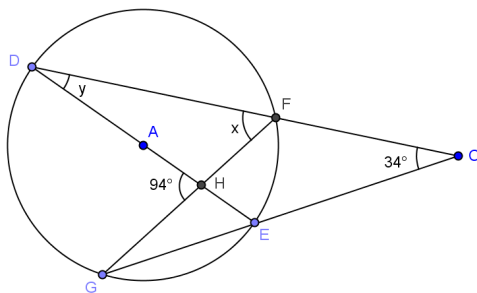

$x = 64^\circ, y = 30^\circ$

6. The radius of circle A is 4. \overline{DC} and \overline{CE} are tangent to the circle with $DC = 12$. Find $m\widehat{EBD}$ and the area of quadrilateral DAEC rounded to the nearest hundredth.

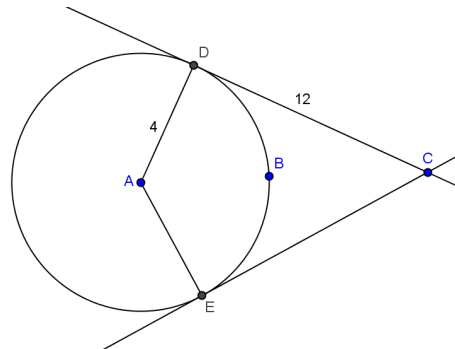

$m\widehat{EBD} = 143.13^\circ, \text{Area} = 48 \text{ square units}$

7.

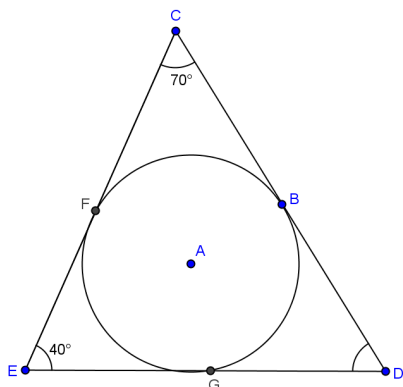

$$m\widehat{BG} = m\widehat{FB} = 110^\circ, m\widehat{GF} = 140^\circ$$

8.

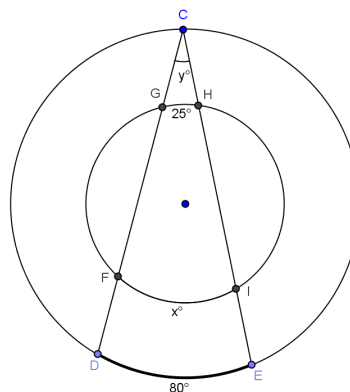

$$x = 105, y = 40$$

9. The radius of a circle is 6.

- a. If the angle formed between two tangent lines to the circle is 60° , how long are the segments between the point of intersection of the tangent lines and the circle?

12

- b. If the angle formed between the two tangent lines is 120° , how long are the segments between the point of intersection of the tangent lines and the circle? Round to the nearest hundredth.

6.93

10. \overline{DC} and \overline{EC} are tangent to circle A. Prove $BD = BE$.

Join AD, AE, BD, and BE.

$AD = AE$ radii of same circle

$AC = AC$ reflexive property

$m\angle ADC = m\angle AEC = 90^\circ$ radii perpendicular to tangent lines at point of tangency

$\triangle ADC \cong \triangle AEC$ HL

$m\angle CAE = m\angle CAD$ CPCTC

$\widehat{DB} \cong \widehat{EB}$ congruent angles intercept congruent arcs

$DB = EB$ congruent arcs intercept chords of equal measure

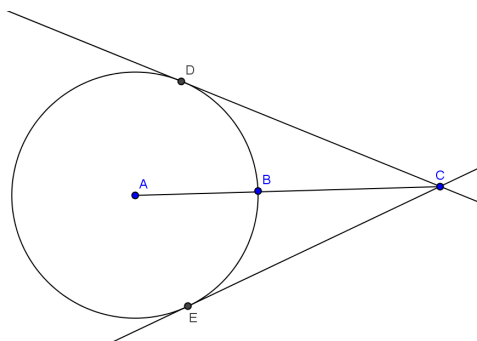



Lesson 16: Similar Triangles in Circle-Secant (or Circle-Secant-Tangent) Diagrams

Student Outcomes

- Students find “missing lengths” in circle-secant or circle-secant-tangent diagrams.

Lesson Notes

The Opening Exercise reviews Lesson 15, secant lines that intersect outside of circles. In this lesson, students continue the study of secant lines and circles, but the focus changes from angles formed to segment lengths and their relationships to each other. Examples 1 and 2 allow students to measure the segments formed by intersecting secant lines and develop their own formulas. Example 3 has students prove the formulas that they developed in the first two examples.

This lesson will focus heavily on MP.8, as students work to articulate relationships among segment lengths by noticing patterns in repeated measurements and calculations.

Classwork

Opening Exercise (5 minutes)

We have just studied several relationships between angles and arcs of a circle. This exercise should be completed individually and asks students to state the type of angle and the angle/arc relationship, and then find the measure of an arc. Use this as an informal assessment to monitor student understanding.

Opening Exercise

Identify the type of angle and the angle/arc relationship, and then find the measure of x .

a.

$x = 58$; inscribed angle is equal to half intercepted

b.

$x = 86$; angle with vertex inside arc. circle is half sum of arcs intercepted by angle and its vertical angle.

c.

$x = 18.5$; angle with vertex outside circle has measure of half the difference of larger intercepted arc.

d.

$x = 42.5$; central angle has measure of intercepted arc.

Example 1 (10 minutes)

In Example 1, we study the relationships of segments of secant lines intersecting inside of circles. Students will measure and then find a formula. Allow students to work in pairs and have them construct more circles with secants crossing at exterior points until they see the relationship. Students will need a ruler.

If chords of a circle intersect, the product of the lengths of the segments of one chord is equal to the product of the lengths of the segments of the other chord. $a \cdot b = c \cdot d$.

Scaffolding:

- Model the process of measuring and recording values.
- Ask advanced students to generate an additional diagram that illustrates the pattern shown and explain it.

Example 1

Measure the lengths of the chords in centimeters and record them in the table.

a.

b.

c.

d.

Circle #	a (cm)	b (cm)	c (cm)	d (cm)	Do you notice a relationship?
a	2.5	2.5	2.5	2.5	<i>All are the same measure.</i>
b	2.5	2	3.2	1.6	<i>Not sure.</i>
c	1.4	2.3	1.1	3	$a \cdot b = c \cdot d$
d	0.8	2.2	2.8	0.6	$a \cdot b = c \cdot d$

MP.8

- What relationship did you discover?
 - $a \cdot b = c \cdot d$.
- Say that to your neighbor in words.
 - *If chords of a circle intersect, the product of the lengths of the segments of one chord is equal to the product of the lengths of the segments of the other chord.*

Example 2 (10 minutes)

In the second example, the point of intersection is outside of the circle and students try to develop an equation that works. Students should continue this work in groups.

Example 2
 Measure the lengths of the chords in centimeters and record them in the table.

Circle #	a (cm)	b (cm)	c (cm)	d (cm)	Do you notice a relationship?
a	2.3	3	2.3	3	<i>Product of a and b is equal to product of c and d.</i>
b	1.4	3.6	1.7	2.2	<i>Products aren't equal for these measurements.</i>
c	0.5	3.8	1	1.8	$a(a + b) = c(c + d)$
d	2.6	1.1	2.6	1.1	$a(a + b) = c(c + d)$

- Does the same relationship hold?
 - No.
- Did you discover a different relationship?
 - Yes, $a(a + b) = c(c + d)$.
- Explain the two relationships that you just discovered to your neighbor and when to use each formula.
 - When secant lines intersect inside a circle, use $a \cdot b = c \cdot d$.
 - When secant lines intersect outside of a circle, use $a(a + b) = c(c + d)$.

MP.8

Example 3 (12 minutes)

Students have just discovered relationships between the segments of secant and tangent lines and circles. In Example 3, they will prove why the formulas work mathematically.

Display the diagram at right on the board.

- We are going to prove mathematically why the formulas we found in Examples 1 and 2 are valid using similar triangles.
- Draw \overline{BD} and \overline{EC} .
- Take a few minutes with a partner and prove that $\triangle BFD$ is similar to $\triangle EFC$.
- Allow students time to work while you circulate around the room. Help groups that are struggling. Bring the class back together and have students share their proofs.
 - $m\angle BFD = m\angle EFC$ *Vertical angles*
 - $m\angle BDF = m\angle ECF$ *Inscribed in same arc*
 - $m\angle DBF = m\angle CEF$ *Inscribe in same arc*
 - $\triangle BFD \sim \triangle EFC$ *AA*

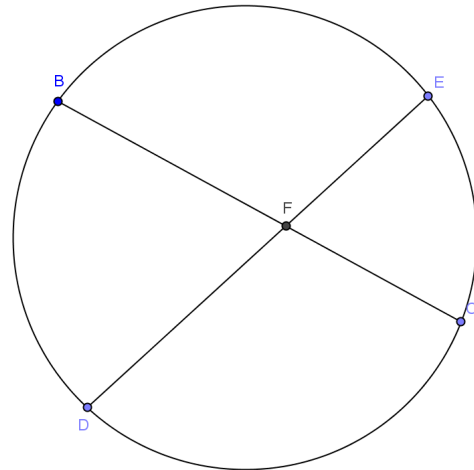

- What is true about similar triangles?
 - *Corresponding sides are proportional.*
- Write a proportion involving sides \overline{BF} , \overline{FC} , \overline{DF} , and \overline{FE} .
 - $\frac{BF}{FE} = \frac{DF}{FC}$
- Can you rearrange this to prove the formula discovered in Example 1?
 - $(BF)(FC) = (DF)(FE)$
- Display the next diagram on the board.
- Display the diagram at right on the board.
- Now let's try to prove the formula we found in Example 2.
- Name two triangles that could be similar.
 - $\triangle CFB$ and $\triangle CED$
- Take a few minutes with a partner and prove that $\triangle CFB$ is similar to $\triangle CED$.

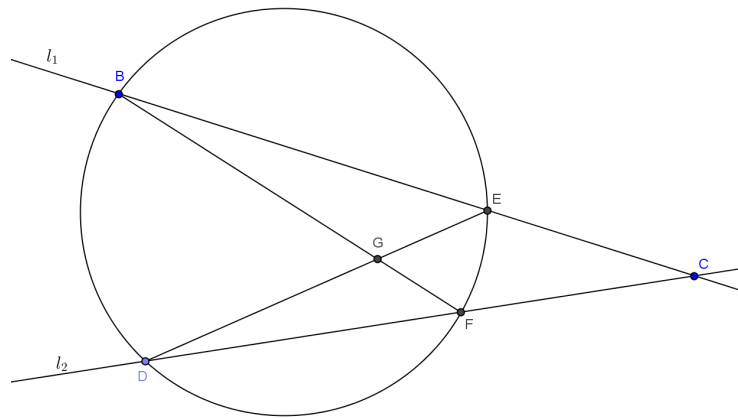

- Allow students time to work while you circulate around the room. Help groups that are struggling. Bring the class back together and have students share their proofs.
 - $m\angle C = m\angle C$ *Common angle*
 - $m\angle CBF = m\angle CDE$ *Inscribed in same arc*
 - $\triangle CFB \sim \triangle CED$ *AAA*
- Write a proportion that will be true.
 - $\frac{CB}{CD} = \frac{CF}{CE}$
- Can you rearrange this to prove the formula discovered in Example 2?
 - $(CE)(CB) = (CF)(CD)$
- What if one of the lines is tangent and the other is secant? Show diagram.
 - *Students should be able to reason that*
 $a \cdot a = b(b + c)$
 - $a^2 = b(b + c)$
 - $a = \sqrt{b(b + c)}$.

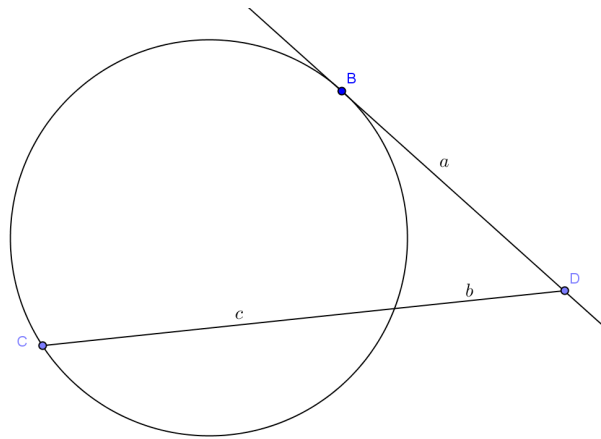

Closing (3 minutes)

We have just concluded our study of secant lines, tangent lines, and circles. In Lesson 15, you completed a table about angle relationships. This summary completes the table adding segment relationships. Complete the table below and compare your answers with your neighbor. Bring class back together to discuss answers to ensure students have the correct formulas in their tables.

Lesson Summary:		
The inscribed angle theorem and its family:		
Diagram	How the two shapes overlap	Relationship between a, b, c and d
	<p><i>Intersection is in the interior of the circle.</i></p>	<p>$a \cdot b = c \cdot d$</p>

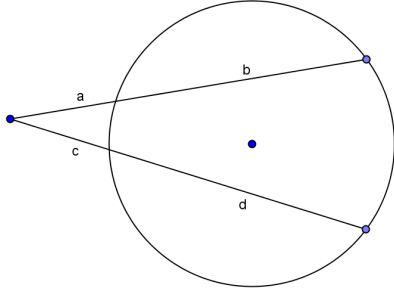
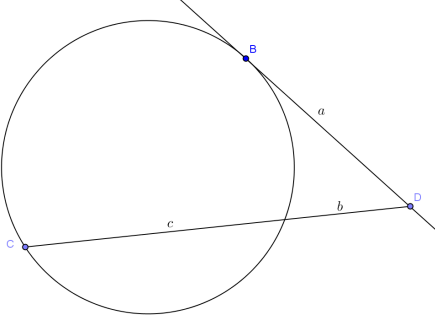
	<p><i>Intersection is on the exterior of the circle.</i></p>	$a(a + b) = c(c + d)$
	<p><i>Tangent and secant are intersecting.</i></p>	$a^2 = b(b + c)$
<p>Lesson Summary</p> <p>THEOREMS:</p> <ul style="list-style-type: none"> ▪ When secant lines intersect inside a circle, use $a \cdot b = c \cdot d$. ▪ When secant lines intersect outside of a circle, use $a(a + b) = c(c + d)$. <p>Relevant Vocabulary</p> <p>SECANT TO A CIRCLE: A <i>secant line to a circle</i> is a line that intersects a circle in exactly two points.</p>		

Exit Ticket (5 minutes)

Name _____

Date _____

Lesson 16: Similar Triangles in Circle-Secant (or Circle-Secant-Tangent) Diagrams

Exit Ticket

1. In the circle below, $m\widehat{GF} = 30^\circ$, $m\widehat{DE} = 120^\circ$, $CG = 6$, $GH = 2$, $FH = 3$, $CF = 4$, $HE = 9$, and $FE = 12$.

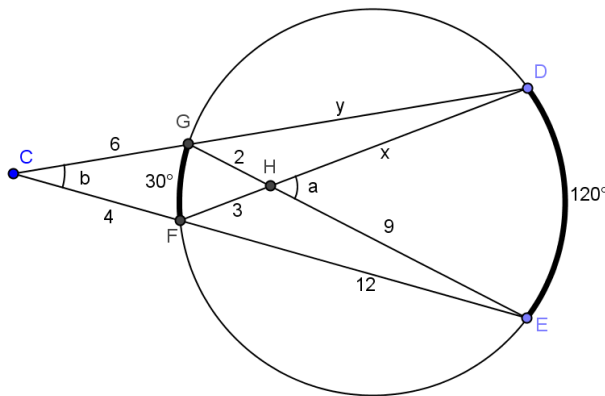

- Find a ($m\angle DHE$).
- Find b ($m\angle DCE$) and explain your answer.
- Find x (HD) and explain your answer.
- Find y (DG).

Exit Ticket Sample Solutions

1. In the circle below, $m\widehat{GF} = 30^\circ$, $m\widehat{DE} = 120^\circ$, $CG = 6$, $GH = 2$, $FH = 3$, $CF = 4$, $HE = 9$, and $FE = 12$.

a. Find a ($m\angle DHE$).

$a = 75^\circ$

b. Find b ($m\angle DCE$).

$b = 45^\circ$; b is an angle with vertex outside of the circle, so it has measure half the difference between its larger and smaller intercepted arcs.

c. Find x (HD).

$x = 6$; x is part of a secant line inside the circle, so $2 \cdot 9 = 3 \cdot x$.

d. Find y (DG).

$y = \frac{14}{3} = 4\frac{2}{3}$

Problem Set Sample Solutions

1. Find x .

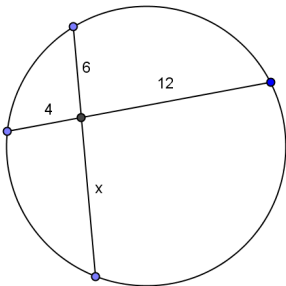

$x = 8$

2. Find x .

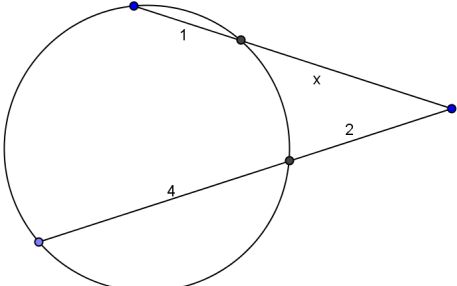

$x = 3$

3. $DF < FB, DF \neq 1, DF < FE$. Prove $DF = 3$

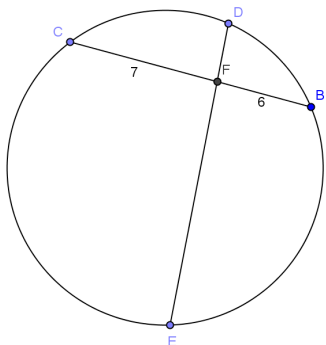

$7 \cdot 6 = 42$, so $DF \cdot FE$ must equal 42. If $DF < FE$, DF could equal 1, 3, or 6. $DF \neq 1$ and $DF < FB$, so DF must equal 3.

4. $CE = 6, CB = 9, CD = 18$. Show $CF = 3$.

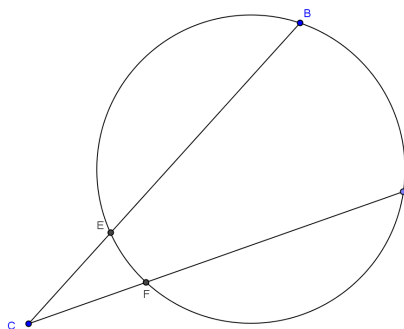

$6 \cdot 9 = 54$ and $18 \cdot CF = 54$. This means $CF = 3$.

5. Find x .

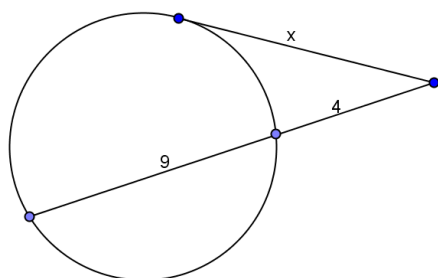

$x = 2\sqrt{13}$

6. Find x .

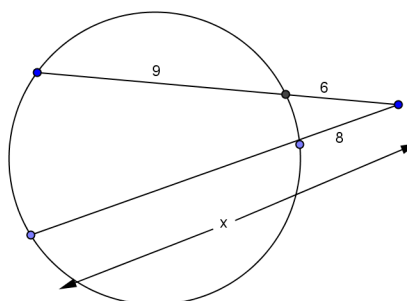

$x = 11.25$

7. Find x .

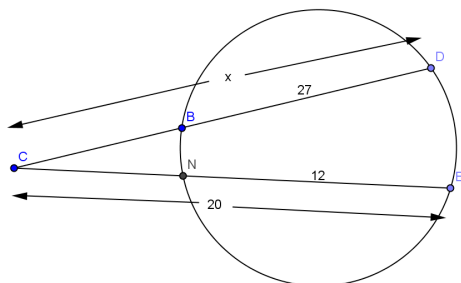

$x = 32$

8. Find x .

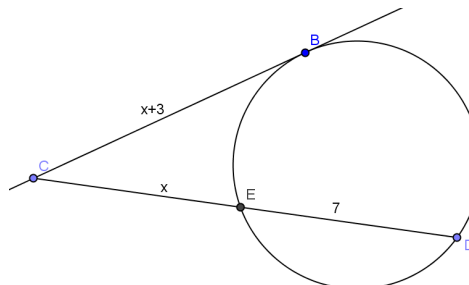

$x = 9$

9. In the circle shown, $DE = 11$, $BC = 10$, $DF = 8$. Find FE , BF , FC .

$FE = 3$, $BF = 4$, $FC = 6$

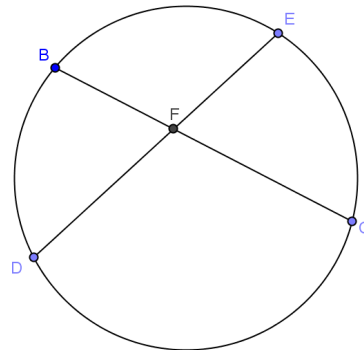

10. In the circle shown, $m\widehat{DBG} = 150^\circ$, $m\widehat{DB} = 30^\circ$, $m\angle CEF = 60^\circ$,

$DF = 8$, $DB = 4$, $GF = 12$.

a. Find $m\angle GDB$.

60°

b. Prove $\triangle DBF \sim \triangle ECF$.

$m\angle BDF = m\angle CEF$ *Angles have same measure.*

$m\angle DFB = m\angle EFC$ *Vertical angles are congruent.*

$\triangle DBF \sim \triangle EFC$ *AA*

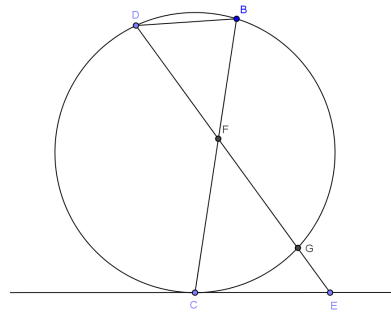

c. Set up a proportion using sides \overline{CE} and \overline{GE} .

$$\frac{8}{GE+12} = \frac{4}{CE} \text{ or } 2CE = GE = 12$$

d. Set up an equation with \overline{CE} and \overline{GE} using a theorem for segment lengths from this section.

$$CE^2 = GE(GE + 12)$$

e. Solve for CE and GE .

$$CE = 8, GE = 4$$



Topic D:

Equations for Circles and Their Tangents

G-GPE.A.1, G-GPE.A.4

Focus Standard:	G-GPE.A.1	Derive the equation of a circle of given center and radius using the Pythagorean Theorem; complete the square to find the center and radius of a circle given by an equation.
	G-GPE.A.4	Use coordinates to prove simple geometric theorems algebraically.
Instructional Days:	3	
	Lesson 17:	Writing the Equation for a Circle (P) ¹
	Lesson 18:	Recognizing Equations of Circles (P)
	Lesson 19:	Equations for Tangent Lines to Circles (P)

Topic D consists of three lessons focusing on MP.7. Students see the structure in the different forms of equations of a circle and lines tangent to circles. In Lesson 17, students deduce the equation for a circle in center-radius form using what they know about the Pythagorean theorem and the distance between two points on the coordinate plane (**G-GPE.A.1**). Students first understand that a circle whose center is at the origin of the coordinate plane is given by $x^2 + y^2 = r^2$, where r is the radius. Using their knowledge of translation, students derive the general formula for a circle as $(x - a)^2 + (y - b)^2 = r^2$, where r is the radius of the circle, and (a, b) is the center of the circle. In Lesson 18, students use their algebraic skills of factoring and completing the square to transform equations into center-radius. Students prove that $x^2 + y^2 + Ax + By + C = 0$ is the equation of a circle and find the formula for the center and radius of this circle (**G-GPE.A.4**). Students know how to recognize the equation of a circle once the equation format is in center-radius. In Lesson 19, students again use algebraic skills to write the equations of lines, specifically lines tangent to a circle, using information about slope and/or points on the line. Recalling students' understanding of tangent from Lesson 11 and combining that with the equations of circles from Lessons 17 and 18, students determine the equation of tangent lines to a circle from points outside of the circle.

¹ Lesson Structure Key: P-Problem Set Lesson, M-Modeling Cycle Lesson, E-Exploration Lesson, S-Socratic Lesson



Lesson 17: Writing the Equation for a Circle

Student Outcomes

- Students write the equation for a circle in center-radius form, $(x - a)^2 + (y - b)^2 = r^2$, using the Pythagorean Theorem or the distance formula.
- Students write the equation of a circle given the center and radius. Students identify the center and radius of a circle given the equation.

Lesson Notes

In this lesson, students deduce the equation for a circle in center-radius form, $(x - a)^2 + (y - b)^2 = r^2$, using what they already know about the Pythagorean Theorem and the distance formula: the distance between two points, (x_1, y_1) and (x_2, y_2) is $d = \sqrt{(x_2 - x_1)^2 + (y_2 - y_1)^2}$. Exercise 11 foreshadows the work of the next lesson where students will need to complete the square in order to determine the equation of a circle.

Classwork

Opening Exercise (4 minutes)

Opening Exercise

- What is the length of the segment shown on the coordinate plane below?

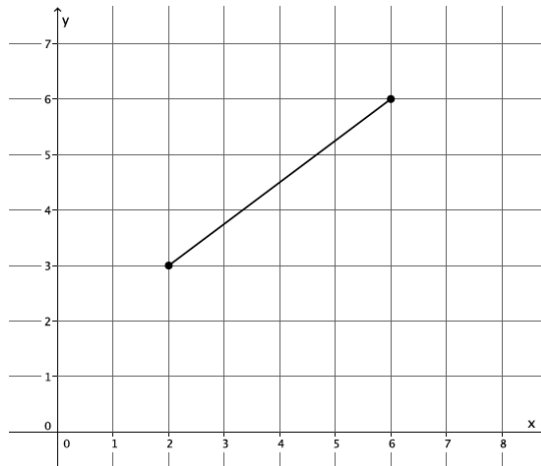

Students may use the Pythagorean Theorem or the distance formula to determine the length of the segment to be 5 units.

2. Use the distance formula to determine the distance between points (9, 15) and (3, 7).

$$\begin{aligned}\sqrt{(9-3)^2 + (15-7)^2} &= d \\ \sqrt{36 + 64} &= d \\ 10 &= d\end{aligned}$$

Example 1 (10 minutes)

Example 1

If we graph all of the points whose distance from the origin is equal to 5, what shape will be formed?

By definition, the set of all points in the plane whose distance from the origin is 5 units is called a circle.

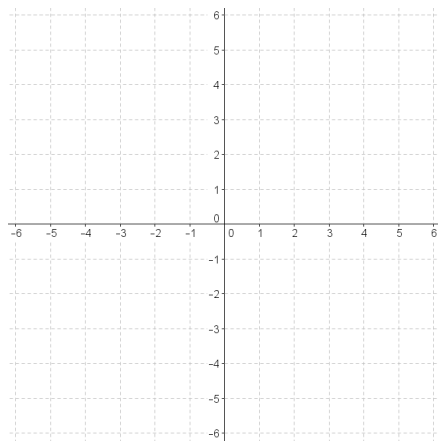

- Our goal now is to find the coordinates of eight of those points that comprise the circle. Four are very easy to find. What are they?

Provide time for students to think and discuss how to find the coordinates of the four “easy” points. Have students explain how they got their coordinates.

- The four points are (0,5), (0,−5), (5,0) and (−5,0). To find these points, we went right, left, up, and down 5 units from the origin.
- Now we need to locate four more points on the circle. We need the distance from the origin, i.e., the center of the circle, to be 5. Graphically, we are looking for the coordinates (x, y) that are exactly 5 units from the center of the circle:

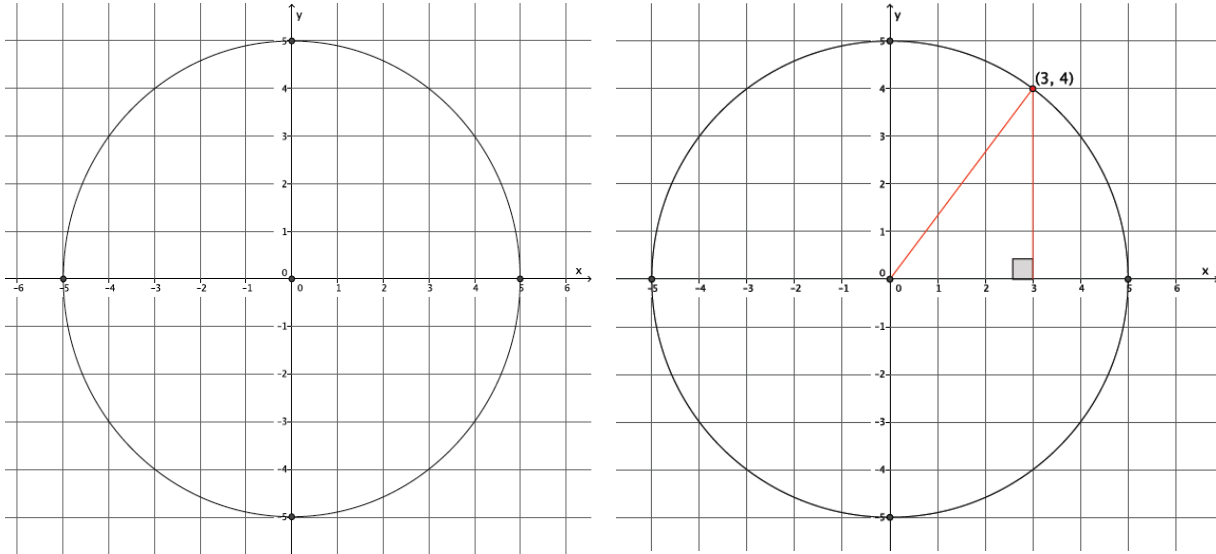

- Identify one other point on the circle that appears to be 5 units from the center of the circle.
 - *Students may identify (3,4), (-3,4), (-3,-4), (3,-4), (4,3), (-4,3), (-4,-3), or (4,-3).*
- What can we do to be sure that the distance between the center of the circle and the identified point is in fact 5?

Provide time for students to discuss the answer to this question. Some students may say they could use the Pythagorean Theorem and others may say they could use the distance formula. Since the distance formula is derived from the Pythagorean Theorem, both answers are correct. Encourage students to explain their use of either strategy. For example, using the Pythagorean Theorem and point (3,4), we have the following:

Using the coordinates, we know that one leg of the right triangle formed above has length 3 and the other has length 4. We must check that the hypotenuse is equal to 5. To that end, $3^2 + 4^2 = 5^2$ is true, and the point (3,4) is 5 units from the center of the circle. This process can be repeated to check the three other points, but it is not necessary.

Scaffolding:

Using a chart to organize calculations could be helpful. See example below.

The distance formula will bring students to the same conclusion. To find the distance between the origin and the point (3,4), we must calculate $\sqrt{(3-0)^2 + (4-0)^2}$. We must show that the distance between the two points is 5. Make clear to students that using the distance formula in this case, where the center is at the origin, is no different from the strategy of using the Pythagorean Theorem because $\sqrt{(3-0)^2 + (4-0)^2} = \sqrt{3^2 + 4^2} = 5$.

Point	Distance To Center
(3,4)	$\sqrt{(3-0)^2 + (4-0)^2} = 25$
(5,0)	$\sqrt{(5-0)^2 + (0-0)^2} = 25$
(4,3)	$\sqrt{(4-0)^2 + (3-0)^2} = 25$
(-3,4)	$\sqrt{(-3-0)^2 + (4-0)^2} = 25$
(4,-3)	$\sqrt{(4-0)^2 + (-3-0)^2} = 25$

- Based on our work using the Pythagorean Theorem, we can say that any point (x,y) on this circle whose center is at the origin (0,0) and whose radius is 5 must satisfy the equation $x^2 + y^2 = 5^2$. In other words, all solutions to the equation $x^2 + y^2 = 5^2$ are the points of the circle.

Example 2 (10 minutes)

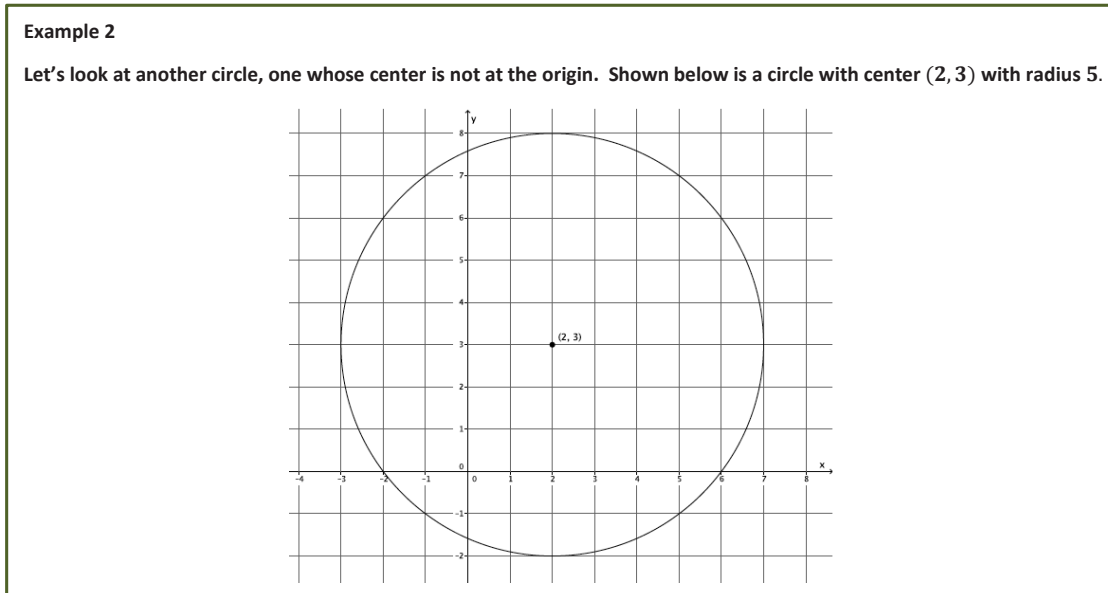

- Again, there are four points that are easy to locate and others that can be verified using the Pythagorean Theorem or distance formula. What are the differences between this circle and the one we just looked at in Example 1?

Provide students time to discuss the answer to this question.

- Both of the circles have a radius of 5, but their centers are different, which makes the points that comprise the circles different.

MP.3

- Are the circles congruent? Is there a sequence of basic rigid motions that would take this circle to the origin? Explain.
 - Yes, the circles are congruent because both have a radius equal to 5. We could map one circle onto the other using a translation. For example, we could translate the circle with center at (2,3) to the origin by translating along a vector from point (2,3) to point (0,0).
- What effect does the translation have on all of the points from the circle above?

Scaffolding:
 Give students specific points to compare. For example, compare the point (5,7) from the circle above to the point (3,4) on the circle whose center is at the origin.

Show the circles side by side. Provide time for students to discuss this with partners.

- Each x -coordinate is decreased by 2, and each y -coordinate is decreased by 3.
- The effect that translation has on the points can be expressed as the following. Let (x, y) be any point on the circle with center (2,3). Then, the coordinates of all of the points (x, y) after the translation are: $((x - 2), (y - 3))$.
- Since the radius is equal to 5, we can locate any point (x, y) on the circle using the Pythagorean Theorem as we did before.

$$(x - 2)^2 + (y - 3)^2 = 5^2$$

The solutions to this equation are all the points of a circle whose radius is 5 and center is at (2,3).

- What do the numbers 2, 3, and 5 represent in the equation above?
 - *The 2 and 3 represent the location of the center (2, 3), and the 5 is the radius.*
- Assume we have a circle with radius 5 whose center is at (a, b) . What is an equation whose graph is that circle?

Provide time for students to discuss this in pairs.

- *The circle with radius 5 and center at (a, b) is given by the graph of the equation $(x - a)^2 + (y - b)^2 = 5^2$.*
- Assume we have a circle with radius r whose center is at (a, b) . What is an equation whose graph is that circle?

Provide time for students to discuss this in pairs.

- *The circle with radius r and center at (a, b) is given by the graph of the equation $(x - a)^2 + (y - b)^2 = r^2$.*
- The last equation, $(x - a)^2 + (y - b)^2 = r^2$, is the general equation for any circle with radius r and center (a, b) .

Exercises 3–11 (12 minutes)

Students should be able to complete Exercises 3–5 independently. Check that the answers to Exercises 3–5 are correct before assigning the remaining exercises in the set.

Exercises

3. Write an equation for the circle whose center is at $(9, 0)$ and has radius 7.

$$(x - 9)^2 + y^2 = 49$$

4. Write an equation whose graph is the circle below.

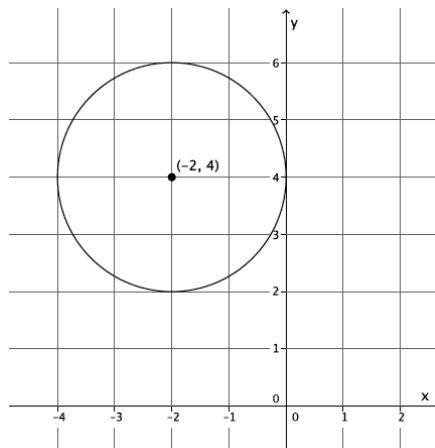

$$(x + 2)^2 + (y - 4)^2 = 4$$

5. What is the radius and center of the circle given by the equation $(x + 12)^2 + (y - 4)^2 = 81$?

The radius is 9, and the center is $(-12, 4)$.

6. Petra is given the equation $(x - 15)^2 + (y + 4)^2 = 100$ and identifies its graph as a circle whose center is $(-15, 4)$ and radius is 10. Has Petra made a mistake? Explain.

Petra did not identify the correct center. The general form for the equation of a circle is given by $(x - a)^2 + (y - b)^2 = r^2$, where (a, b) is the center and r is the radius. Petra noted the value of a as -15 when it is really 15, and the value of b as 4 when it is really -4 . Therefore, Petra should have identified the center as $(15, -4)$. The radius was identified correctly.

7.

- a. What is the radius of the circle with center $(3, 10)$ that passes through $(12, 12)$?

$$\begin{aligned}(x - 3)^2 + (y - 10)^2 &= r^2 \\ (12 - 3)^2 + (12 - 10)^2 &= r^2 \\ 81 + 4 &= r^2 \\ \sqrt{85} &= r\end{aligned}$$

- b. What is the equation of this circle?

$$(x - 3)^2 + (y - 10)^2 = 85$$

8. A circle with center $(2, -5)$ is tangent to the x -axis.

- a. What is the radius of the circle?

$$r = 5$$

- b. What is the equation of the circle?

$$(x - 2)^2 + (y + 5)^2 = 25$$

9. Two points in the plane, $A = (-3, 8)$ and $B = (17, 8)$, represent the endpoints of the diameter of a circle.

- a. What is the center of the circle? Explain.

$(7, 8)$; the midpoint of the diameter.

- b. What is the radius of the circle? Explain.

10; the distance from one endpoint to the center.

- c. Write the equation of the circle.

$$(x - 7)^2 + (y - 8)^2 = 100$$

10. Consider the circles with equations:

$$\begin{aligned}x^2 + y^2 &= 25 \text{ and} \\ (x - 9)^2 + (y - 12)^2 &= 100.\end{aligned}$$

- a. What are the radii of the circles?

The radii are 5 and 10.

- b. What is the distance between the centers of the circles?

$$d = \sqrt{(9 - 0)^2 + (12 - 0)^2}$$

$$d = 15$$

- c. Make a rough sketch of the two circles to explain why the circles must be tangent to one another.

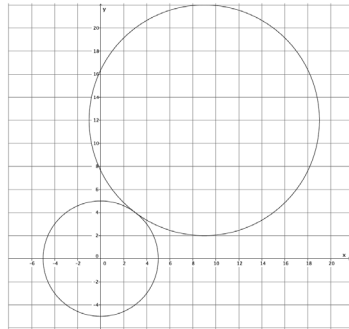

The circles must be tangent because there is just one point that is common to both graphs (or there is only one solution that satisfies both equations), i.e., (3, 3).

11. A circle is given by the equation $(x^2 + 2x + 1) + (y^2 + 4y + 4) = 121$.

- a. What is the center of the circle?

The center is at $(-1, -2)$.

- b. What is the radius of the circle?

The radius is 11.

- c. Describe what you had to do in order to determine the center and the radius of the circle.

I had to factor each of the trinomials to get the equation in the proper form in order to identify the center of the circle. To get the radius, I had to take the square root of 121.

Scaffolding:

- If students are struggling, have them practice factoring perfect square trinomials.
- $a^2 + 2ab + b^2 = (a + b)^2$
- $a^2 - 2ab + b^2 = (a - b)^2$
- Factor
 - $x^2 + 4x + 4$
 - $x^2 - 6x + 9$

Closing (4 minutes)

Have students summarize the main points of the lesson in writing, by talking to a partner, or as a whole class discussion. Use the questions below, if necessary.

- Which fundamental theorem was critical for allowing us to write the equation of a circle?
- The equation of a circle can always be rewritten into what form?
- What parts of the equation give information about the center of the circle? The radius?

Lesson Summary

$(x - a)^2 + (y - b)^2 = r^2$ is the general equation for any circle with radius r and center (a, b) .

Exit Ticket (5 minutes)

Name _____

Date _____

Lesson 17: Writing the Equation for a Circle

Exit Ticket

1. Describe the circle given by the equation $(x - 7)^2 + (y - 8)^2 = 9$.
2. Write the equation for a circle with center $(0, -4)$ and radius 8.
3. Write the equation for the circle shown below.

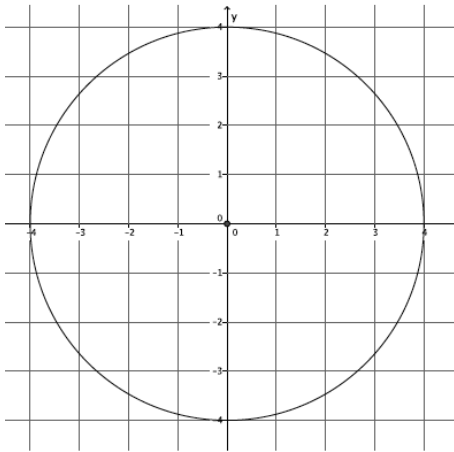

4. A circle has a diameter with endpoints at $(6, 5)$ and $(8, 5)$. Write the equation for the circle.

Exit Ticket Sample Solutions

1. Describe the circle given by the equation $(x - 7)^2 + (y - 8)^2 = 9$.

The circle has a center at (7, 8) and a radius of 3.

2. Write the equation for a circle with center $(0, -4)$ and radius 8.

$$x^2 + (y + 4)^2 = 64$$

3. Write the equation for the circle shown below.

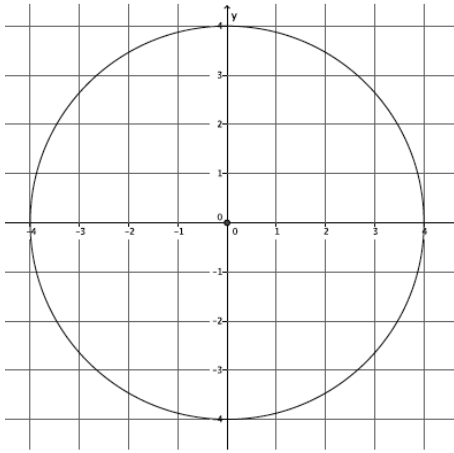

$$x^2 + y^2 = 16$$

4. A circle has a diameter with endpoints at $(6, 5)$ and $(8, 5)$. Write the equation for the circle.

$$(x - 7)^2 + (y - 5)^2 = 1$$

Problem Set Sample Solutions

1. Write the equation for a circle with center $(\frac{1}{2}, \frac{3}{7})$ and radius $\sqrt{13}$.

$$(x - \frac{1}{2})^2 + (y - \frac{3}{7})^2 = 13$$

2. What is the center and radius of the circle given by the equation $x^2 + (y - 11)^2 = 144$?

The center is located at (0, 11), and the radius is 12.

3. A circle is given by the equation $x^2 + y^2 = 100$. Which of the following points are on the circle?

- a. $(0, 10)$

This point is on the circle.

b. $(-8, 6)$

This point is on the circle.

c. $(-10, -10)$

This point is not on the circle.

d. $(45, 55)$

This point is not on the circle.

e. $(-10, 0)$

This point is on the circle.

4. Determine the center and radius of each circle:

a. $3x^2 + 3y^2 = 75$

The center is at $(0, 0)$, and the radius is 5.

b. $2(x + 1)^2 + 2(y + 2)^2 = 10$

The center is at $(-1, -2)$, and the radius is $\sqrt{5}$.

c. $4(x - 2)^2 + 4(y - 9)^2 - 64 = 0$

The center is at $(2, 9)$, and the radius is 4.

5. A circle has center $(-13, \pi)$ and passes through the point $(2, \pi)$.

a. What is the radius of the circle?

$$\begin{aligned} (x + 13)^2 + (y - \pi)^2 &= r^2 \\ (2 + 13)^2 + (\pi - \pi)^2 &= r^2 \\ 15^2 &= r^2 \\ 15 &= r \end{aligned}$$

b. Write the equation of the circle.

$$(x + 13)^2 + (y - \pi)^2 = 225$$

6. Two points in the plane, $A = (19, 4)$ and $B = (19, -6)$, represent the endpoints of the diameter of a circle.

a. What is the center of the circle?

$$(19, -1)$$

b. What is the radius of the circle?

$$5$$

c. Write the equation of the circle.

$$(x - 19)^2 + (y + 1)^2 = 25$$

7. Write the equation of the circle shown below.

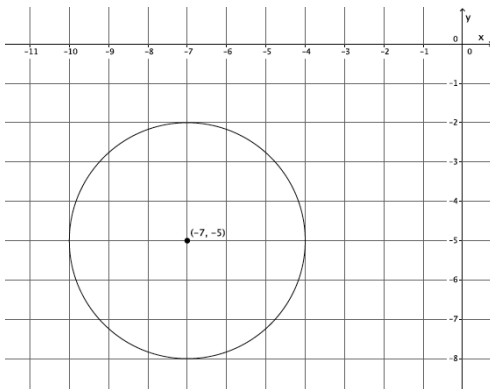

$$(x + 7)^2 + (y + 5)^2 = 9$$

8. Write the equation of the circle shown below.

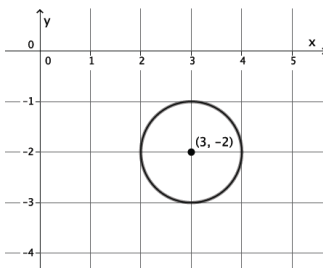

$$(x - 3)^2 + (y + 2)^2 = 1$$

9. Consider the circles with equations:

$$x^2 + y^2 = 2 \text{ and } (x - 3)^2 + (y - 3)^2 = 32.$$

a. What are the radii of the two circles?

The radii are $\sqrt{2}$ and $\sqrt{32}$.

b. What is the distance between their centers?

$$\sqrt{32} - \sqrt{2} = 4\sqrt{2} - \sqrt{2} = 3\sqrt{2}$$

c. Make a rough sketch of the two circles to explain why the circles must be tangent to one another.

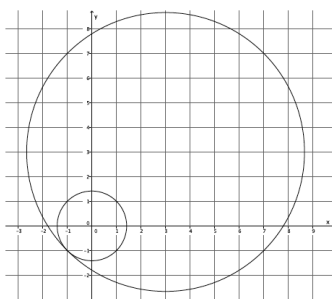

The circles must be tangent because there is just one point that is common to both graphs (or there is only one solution that satisfies both equations), i.e., $(-1, -1)$.



Lesson 18: Recognizing Equations of Circles

Student Outcomes

- Students complete the square in order to write the equation of a circle in center-radius form.
- Students recognize when a quadratic in x and y is the equation for a circle.

Lesson Notes

This lesson builds from the understanding of equations of circles in Lesson 17. The goal is for students to recognize when a quadratic equation in x and y is the equation for a circle. The Opening Exercise reminds students of algebraic skills that are needed in this lesson, specifically multiplying binomials, factoring trinomials, and completing the square. Throughout the lesson, students will need to complete the square (**A-SSE.3b**) in order to determine the center and radius of the circle. Completing the square was taught in Grade 9, Module 4, Lessons 11 and 12.

Classwork

Opening Exercise (6 minutes)

It is important that students can factor trinomial squares and complete the square in order to recognize equations of circles. Use the following exercises to determine which students may need remediation of these skills.

Opening Exercise

<table style="border-collapse: collapse;"> <tr> <td style="border: none;"></td> <td style="border: none; text-align: center;">x</td> <td style="border: none; text-align: center;">3</td> <td style="border: none;"></td> </tr> <tr> <td style="border: none; text-align: center;">x</td> <td style="border: 1px solid black; padding: 5px;">x^2</td> <td style="border: 1px solid black; padding: 5px;">$3x$</td> <td style="border: none;"></td> </tr> <tr> <td style="border: none; text-align: center;">3</td> <td style="border: 1px solid black; padding: 5px;">$3x$</td> <td style="border: 1px solid black; padding: 5px;">?</td> <td style="border: none;"></td> </tr> </table>		x	3		x	x^2	$3x$		3	$3x$?		=	40
	x	3												
x	x^2	$3x$												
3	$3x$?												
<table style="border-collapse: collapse;"> <tr> <td style="border: none;"></td> <td style="border: none; text-align: center;">x</td> <td style="border: none; text-align: center;">3</td> <td style="border: none;"></td> </tr> <tr> <td style="border: none; text-align: center;">x</td> <td style="border: 1px solid black; padding: 5px;">x^2</td> <td style="border: 1px solid black; padding: 5px;">$3x$</td> <td style="border: none;"></td> </tr> <tr> <td style="border: none; text-align: center;">3</td> <td style="border: 1px solid black; padding: 5px;">$3x$</td> <td style="border: 1px solid black; padding: 5px;">9</td> <td style="border: none;"></td> </tr> </table>		x	3		x	x^2	$3x$		3	$3x$	9		=	49
	x	3												
x	x^2	$3x$												
3	$3x$	9												

a. Express this as a trinomial: $(x - 5)^2$.
 $(x - 5)^2 = x^2 - 10x + 25$

b. Express this as a trinomial: $(x + 4)^2$.
 $(x + 4)^2 = x^2 + 8x + 16$

c. Factor the trinomial: $x^2 + 12x + 36$.
 $x^2 + 12x + 36 = (x + 6)^2$

d. Complete the square to solve the following equation: $x^2 + 6x = 40$.
 $x^2 + 6x = 40$
 $x^2 + 6x + 9 = 40 + 9$
 $(x + 3)^2 = 49$
 $x + 3 = 7$
 $x = 4$

Scaffolding:

- For English language learners and students that may be below grade level, a visual approach may help students understand completing the square.
- For example, students may view an equation such as $x^2 + 6x = 40$ first by developing a visual that supports the left side of the equation.

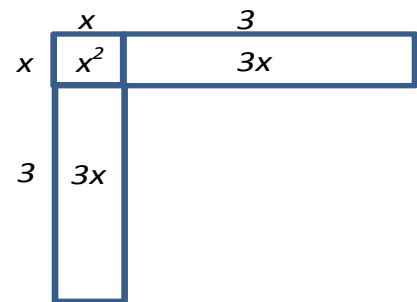

- Students then view solving the equation as finding the missing piece (literally, completing the square).

Ask students to share answers and discuss parts that they may have found challenging.

Example 1 (4 minutes)

Example 1

The following is the equation of a circle with radius 5 and center (1, 2). Do you see why?

$$x^2 - 2x + 1 + y^2 - 4y + 4 = 25$$

Provide time for students to think about this in pairs or small groups. If necessary, guide their thinking by telling students that parts (a)–(c) in the Opening Exercise are related to the work they will be doing in this example. Allow individual students or groups of students to share their reasoning as to how they make the connection between the information given about a circle and the equation. Once students have shared their thinking, continue with the reasoning below.

MP.1

- We know that the equation $x^2 - 2x + 1 + y^2 - 4y + 4 = 25$ is a circle with radius 5 and center (1, 2) because when we multiply out the equation $(x - 1)^2 + (y - 2)^2 = 5^2$, we get $x^2 - 2x + 1 + y^2 - 4y + 4 = 25$.

Scaffolding:

Ask students to identify a point (perhaps by sketching the graph) that should be on the circle, and verify that it satisfies the equation given.

Provide students time to verify that these equations are equal.

- Recall the equation for a circle with center (a, b) and radius r from the previous lesson.
 - $(x - a)^2 + (y - b)^2 = r^2$
- Multiply out each of the binomials to write an equivalent equation.
 - $x^2 - 2ax + a^2 + y^2 - 2by + b^2 = r^2$

- Sometimes equations of circles are presented in this simplified form. To easily identify the center and the radius of the graph of the circle, we sometimes need to factor and/or complete the square in order to rewrite the equation back in its standard form $(x - a)^2 + (y - b)^2 = r^2$.

Exercise 1 (3 minutes)

Use the exercise below to assess students' understanding of the content in Example 1.

Exercise

1. Rewrite the following equations in the form $(x - a)^2 + (y - b)^2 = r^2$.

a. $x^2 + 4x + 4 + y^2 - 6x + 9 = 36$
 $(x + 2)^2 + (y - 3)^2 = 36$

b. $x^2 - 10x + 25 + y^2 + 14y + 49 = 4$
 $(x - 5)^2 + (y + 7)^2 = 4$

Scaffolding:

- Students can draw squares as in the Opening Exercise to complete the square.
- For advanced learners, offer equations with coefficients on one or both of the squared terms. For example,
 $3x^2 + 12x + 4y^2 - 48y = 197$.

Example 2 (5 minutes)

Example 2

What is the center and radius of the following circle?

$$x^2 + 4x + y^2 - 12y = 41$$

Provide time for students to think about this in pairs or small groups. If necessary, guide their thinking by telling students that part (d) in the Opening Exercise is related to the work they will be doing in this example. Allow individual students or groups of students to share their reasoning as to how they determine the radius and center of the circle.

MP.1

- We can complete the square, twice, in order to rewrite the equation in the necessary form.

First, $x^2 + 4x$:

$$x^2 + 4x + 4 = (x + 2)^2.$$

Second, $y^2 - 12y$:

$$y^2 - 12y + 36 = (y - 6)^2.$$

Then,

$$\begin{aligned} x^2 + 4x + y^2 - 12y &= 41 \\ (x^2 + 4x + 4) + (y^2 - 12y + 36) &= 41 + 4 + 36 \\ (x + 2)^2 + (y - 6)^2 &= 81. \end{aligned}$$

Therefore, the center is at $(-2, 6)$, and the radius is 9.

Exercises 2–4 (6 minutes)

Use the exercise below to assess students' understanding of the content in Example 2.

Exercises

2. Identify the center and radius for each of the following circles.

a. $x^2 - 20x + y^2 + 6y = 35$

$$(x - 10)^2 + (y + 3)^2 = 144$$

The center is (10, -3), and the radius is 12.

b. $x^2 - 3x + y^2 - 5y = \frac{19}{2}$

$$\left(x - \frac{3}{2}\right)^2 + \left(y - \frac{5}{2}\right)^2 = 18$$

The center is $\left(\frac{3}{2}, \frac{5}{2}\right)$, and the radius is $\sqrt{18} = 3\sqrt{2}$.

3. Could the circle with equation $x^2 - 6x + y^2 - 7 = 0$ have a radius of 4? Why or why not?

$$(x - 3)^2 + y^2 = 16$$

Yes, the radius is 4.

4. Stella says the equation $x^2 - 8x + y^2 + 2y = 5$ has a center of (4, -1) and a radius of 5. Is she correct? Why or why not?

$$(x - 4)^2 + (y + 1)^2 = \sqrt{22}$$

The center is (4, -1), but the radius is $\sqrt{22}$. She did not add the values to the left that she added to the right when completing the square.

Scaffolding:

- Allow accelerated groups of students time to complete the square on their own.
- For students who are struggling, ask questions such as the following:
 - “What is the final form we are trying to put this equation in?”
 - “What would we need to add to $x^2 + Ax$ to create a perfect square trinomial?”

Example 3 (8 minutes)

Example 3

Could $x^2 + y^2 + Ax + By + C = 0$ represent a circle?

Let students think about this. Answers will vary.

- The goal is to be able to recognize when the graph of an equation is, in fact, a circle. Suppose we look at $(x - a)^2 + (y - b)^2 = r^2$ another way:

$$x^2 - 2ax + a^2 + y^2 - 2by + b^2 = r^2.$$

- This equation can be rewritten using the commutative and associative properties of addition. We will also use the subtraction property of equality to set the equation equal to zero:

$$x^2 + y^2 - 2ax - 2by + (a^2 + b^2 - r^2) = 0.$$

- What is the equation of a circle?
 - $(x - a)^2 + (y - b)^2 = r^2$

- Expand the equation.
 - $x^2 - 2ax + a^2 + y^2 - 2by + b^2 = r^2$

- Now rearrange terms using the commutative and associative properties of addition to match $x^2 + y^2 + Ax + By + C = 0$.

$$x^2 + y^2 - 2ax - 2by + (a^2 + b^2 - r^2) = 0$$

- What expressions are equivalent to A , B , and C ?
 - $A = -2a$, $B = -2b$, and $C = a^2 + b^2 - r^2$, where A , B , and C are constants.
- So, could $x^2 + y^2 + Ax + By + C = 0$ represent a circle?
 - Yes.

- The graph of the equation $x^2 + y^2 + Ax + By + C = 0$ is a circle, a point, or an empty set. We want to be able to determine which of the three possibilities is true for a given equation.

- Let's begin by completing the square: $x^2 + y^2 + Ax + By + C = 0$.

$$x^2 + y^2 + Ax + By + C = 0$$

$$x^2 + Ax + \underline{\hspace{1cm}} + y^2 + By + \underline{\hspace{1cm}} = -C$$

$$x^2 + Ax + \left(\frac{A}{2}\right)^2 + y^2 + By + \left(\frac{B}{2}\right)^2 = -C + \left(\frac{A}{2}\right)^2 + \left(\frac{B}{2}\right)^2$$

$$\left(x + \frac{A}{2}\right)^2 + \left(y + \frac{B}{2}\right)^2 = -C + \left(\frac{A}{2}\right)^2 + \left(\frac{B}{2}\right)^2$$

$$\left(x + \frac{A}{2}\right)^2 + \left(y + \frac{B}{2}\right)^2 = -\frac{4C}{4} + \frac{A^2}{4} + \frac{B^2}{4}$$

$$\left(x + \frac{A}{2}\right)^2 + \left(y + \frac{B}{2}\right)^2 = \frac{A^2 + B^2 - 4C}{4}$$

- Just as the discriminant is used to determine how many times a graph will intersect the x -axis, we use the right side of the equation above to determine what the graph of the equation will look like.

- If the fraction on the right is positive, then we can identify the center of the circle as $\left(-\frac{A}{2}, -\frac{B}{2}\right)$ and the radius

$$\text{as } \sqrt{\frac{A^2 + B^2 - 4C}{4}} = \frac{\sqrt{A^2 + B^2 - 4C}}{2} = \frac{1}{2}\sqrt{A^2 + B^2 - 4C}.$$

- What do you think it means if the fraction on the right is zero?
 - It means we could locate a center, $\left(-\frac{A}{2}, -\frac{B}{2}\right)$, but the radius is 0; therefore, the graph of the equation is a point, not a circle.

- What do you think it means if the fraction on the right is negative?
 - It means that we have a negative length of a radius, which is impossible.

- When the fraction on the right is negative, we have an empty set. That is, there are no possible solutions to this equation because the sum of two squared numbers cannot be negative. If there are no solutions, then there are no ordered points to graph.

- We can apply this knowledge to equations whose graphs we cannot easily identify. For example, write the equation $x^2 + y^2 + 2x + 4y + 5 = 0$ in the form of $(x - a)^2 + (y - b)^2 = r^2$.

$$x^2 + y^2 + 2x + 4y + 5 = 0$$

$$(x + 2x + 1) + (y + 4y + 4) + 5 = 5$$

$$(x + 1)^2 + (y + 2)^2 = 0$$

- Since the right side of the equation is zero, then the graph of the equation is a point, $(-1, -2)$.

Exercise 5 (6 minutes)

Use the exercise below to assess students' understanding of the content in Example 3.

5. Identify the graphs of the following equations as a circle, a point, or an empty set.

a. $x^2 + y^2 + 4x = 0$

$$\begin{aligned}x^2 + 4x + 4 + y^2 &= 4 \\(x + 2)^2 + y^2 &= 4\end{aligned}$$

The right side of the equation is positive, so the graph of the equation is a circle.

b. $x^2 + y^2 + 6x - 4y + 15 = 0$

$$\begin{aligned}(x^2 + 6x + 9) + (y^2 - 4y + 4) + 15 &= 13 \\(x - 3)^2 + (y - 2)^2 &= -2\end{aligned}$$

The right side of the equation is negative, so the graph of this equation cannot be a circle; it is an empty set.

c. $2x^2 + 2y^2 - 5x + y + \frac{13}{4} = 0$

$$\begin{aligned}\frac{1}{2}(2x^2 + 2y^2 - 5x + y + \frac{13}{4}) &= 0 \\x^2 - \frac{5}{2}x + y^2 + \frac{1}{2}y + \frac{13}{8} &= 0 \\x^2 - \frac{5}{2}x + \left(\frac{5}{4}\right)^2 + y^2 + \frac{1}{2}y + \left(\frac{1}{4}\right)^2 + \frac{13}{8} &= \left(\frac{5}{4}\right)^2 + \left(\frac{1}{4}\right)^2 \\(x - \frac{5}{4})^2 + (y + \frac{1}{4})^2 &= -\frac{13}{8} + \left(\frac{5}{4}\right)^2 + \left(\frac{1}{4}\right)^2 \\(x - \frac{5}{4})^2 + (y + \frac{1}{4})^2 &= -\frac{13}{8} + \frac{26}{16} \\(x - \frac{5}{4})^2 + (y + \frac{1}{4})^2 &= 0\end{aligned}$$

The right side of the equation is equal to zero, so the graph of the equation is a point.

Closing (2 minutes)

Have students summarize the main points of the lesson in writing, by talking to a partner, or as a whole class discussion. Use the questions below, if necessary.

- Describe the algebraic skills that were necessary to work with equations of circles that were not of the form $(x - a)^2 + (y - b)^2 = r^2$.
- Given the graph of a quadratic equation in x and y , how can we recognize it as a circle or something else?

Exit Ticket (5 minutes)

Name _____

Date _____

Lesson 18: Recognizing Equations of Circles

Exit Ticket

1. The graph of the equation below is a circle. Identify the center and radius of the circle.

$$x^2 + 10x + y^2 - 8y - 8 = 0$$

2. Describe the graph of each equation. Explain how you know what the graph will look like.

a. $x^2 + 2x + y^2 = -1$

b. $x^2 + y^2 = -3$

c. $x^2 + y^2 + 6x + 6y = 7$

Exit Ticket Sample Solutions

1. The graph of the equation below is a circle. Identify the center and radius of the circle.

$$x^2 + 10x + y^2 - 8y - 8 = 0$$

$$(x + 5)^2 + (y - 4)^2 = 49$$

The center is $(-5, 4)$, and the radius is 7.

2. Describe the graph of each equation. Explain how you know what the graph will look like.

a. $x^2 + 2x + y^2 = -1$

$$(x + 1)^2 + y^2 = 0$$

The graph of this equation is a point. I can place a center at $(-1, 0)$, but the radius is equal to zero. Therefore, the graph is just a single point.

b. $x^2 + y^2 = -3$

The right side of the equation is negative, so its graph cannot be a circle; it is an empty set.

c. $x^2 + y^2 + 6x + 6y = 7$

$$(x + 3)^2 + (y + 3)^2 = 25$$

The graph of this equation is a circle with center $(-3, -3)$ and radius 5. Since the equation can be put in the form $(x - a)^2 + (y - b)^2 = r^2$, I know the graph of it is a circle.

Problem Set Sample Solutions

1. Identify the center and radii of the following circles.

a. $(x + 25) + y^2 = 1$

The center is $(-25, 0)$, and the radius is 1.

b. $x^2 + 2x + y^2 - 8y = 8$

$$(x + 1)^2 + (y - 4)^2 = 25$$

The center is $(-1, 4)$, and the radius is 5.

c. $x^2 - 20x + y^2 - 10y + 25 = 0$

$$(x - 10)^2 + (y - 5)^2 = 100$$

The center is $(10, 5)$, and the radius is 10.

d. $x^2 + y^2 = 19$

The center is $(0, 0)$, and the radius is $\sqrt{19}$.

e. $x^2 + x + y^2 + y = -\frac{1}{4}$

$$\left(x + \frac{1}{2}\right)^2 + \left(y + \frac{1}{2}\right)^2 = \frac{1}{4}$$

The center is $\left(-\frac{1}{2}, -\frac{1}{2}\right)$, and the radius is $\frac{1}{2}$.

2. Sketch a graph of the following equations.

a. $x^2 + y^2 + 10x - 4y + 33 = 0$

$$(x + 5)^2 + (y - 2)^2 = -4$$

The right side of the equation is negative, so its graph cannot be a circle; it is an empty set, and since there are no solutions, there is nothing to graph.

b. $x^2 + y^2 + 14x - 16y + 104 = 0$

$$(x + 7)^2 + (y - 8)^2 = 9$$

The graph of the equation is a circle with center $(-7, 8)$ and radius 3.

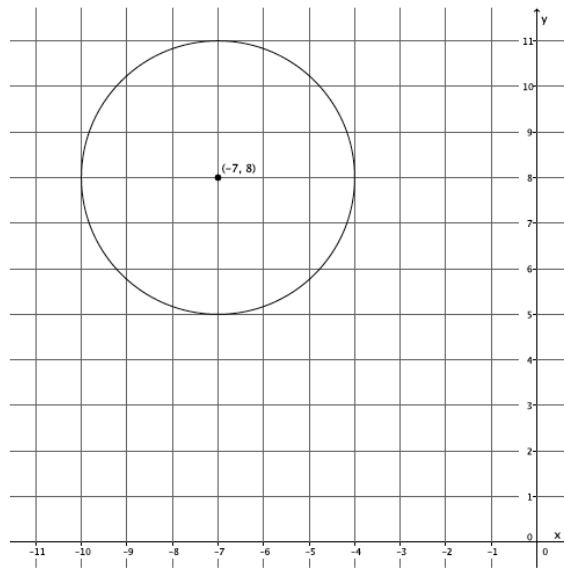

c. $x^2 + y^2 + 4x - 10y + 29 = 0$

$(x + 2)^2 + (y - 5)^2 = 0$

The graph of this equation is a point at $(-2, 5)$.

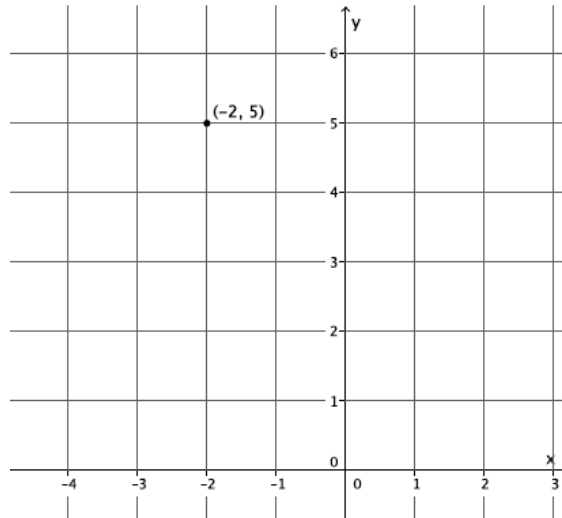

3. Chante claims that two circles given by $(x + 2)^2 + (y - 4)^2 = 49$ and $x^2 + y^2 - 6x + 16y + 37 = 0$ are externally tangent. She is right. Show that she is.

$$(x + 2)^2 + (y - 4)^2 = 49$$

This graph of this equation is a circle with center $(-2, 4)$ and radius 7.

$$(x - 3)^2 + (y + 8)^2 = 36$$

This graph of this equation is a circle with center $(3, -8)$ and radius 6.

By the distance formula, the distance between the two centers is 13, which is precisely the sum of the radii of the two circles. Therefore, these circles will touch only at one point. Put differently, they are externally tangent.

4. Draw a circle. Randomly select a point in the interior of the circle; label the point A . Construct the greatest radius circle with center A that lies within the circular region defined by the original circle. Hint: Draw a line through the center, the circle, and point A .

Constructions will vary. Ensure that students have drawn two circles such that the circle with center A is in the interior and tangent to the original circle.



Lesson 19: Equations for Tangent Lines to Circles

Student Outcomes

- Given a circle, students find the equations of two lines tangent to the circle with specified slopes.
- Given a circle and a point outside the circle, students find the equation of the line tangent to the circle from that point.

Lesson Notes

This lesson builds on the understanding of equations of circles in Lessons 17 and 18 and on the understanding of tangent lines developed in Lesson 11. Further, the work in this lesson relies on knowledge from Module 4 related to **G-GPE.B.4** and **G-GPE.B.5**. Specifically, students must be able to show that a particular point lies on a circle, compute the slope of a line, and derive the equation of a line that is perpendicular to a radius. The goal is for students to understand how to find equations for both lines with the same slope tangent to a given circle and to find the equation for a line tangent to a given circle from a point outside the circle.

Classwork

Opening Exercise (5 minutes)

Students are guided to determine the equation of a line perpendicular to a chord of a given circle.

Opening Exercise

A circle of radius 5 passes through points $A(-3, 3)$ and $B(3, 1)$.

- a. What is the special name for segment AB ?

Segment AB is called a chord.

- b. How many circles can be drawn that meet the given criteria? Explain how you know.

Two circles of radius 5 pass through points A and B . Two distinct circles, at most, can have two points in common.

- c. What is the slope of \overline{AB} ?

The slope of \overline{AB} is $-\frac{1}{3}$.

- d. Find the midpoint of \overline{AB} .

The midpoint of \overline{AB} is $(0, 2)$.

Scaffolding:

- Provide struggling students with a picture of the two circles containing the indicated points.
- Alternatively, struggling students may benefit from simply graphing the two points.

- e. Find the equations of the line containing a diameter of the given circle perpendicular to \overline{AB} .

$$y - 2 = 3(x - 0)$$

- f. Is there more than one answer possible for question 5?

Although two circles may be drawn that meet the given criteria, the diameters of both lie on the line perpendicular to \overline{AB} . That line is the perpendicular bisector of \overline{AB} .

Example 1 (10 minutes)

Example 1

Consider the circle with equation $(x - 3)^2 + (y - 5)^2 = 20$. Find the equations of two tangent lines to the circle that each have slope $-\frac{1}{2}$.

MP.1

Provide time for students to think about this in pairs or small groups. If necessary, guide their thinking by reminding students of their work in Lesson 11 on tangent lines and their work in Lessons 17–18 on equations of circles. Allow individual students or groups of students to share their reasoning as to how to determine the needed equations. Once students have shared their thinking, continue with the reasoning below.

- What is the center of the circle? The radius of the circle?
 - The center is $(3,5)$, and the radius is $\sqrt{20}$.
- If the tangent lines are to have a slope of $-\frac{1}{2}$, what must be the slope of the radii to those tangent lines? Why?
 - The slope of each radius must be 2. A tangent is perpendicular to the radius at the point of tangency. Since the tangent lines must have slopes of $-\frac{1}{2}$, the radii must have slopes of 2, the negative reciprocal of $-\frac{1}{2}$.
- Label the center O . We need to find a point $A(x, y)$ on the circle with a slope of 2. We have $\frac{y-5}{x-3} = 2$, and $(x - 3)^2 + (y - 5)^2 = 20$.
 Since $y - 5 = 2(x - 3)$,
 then $(y - 5)^2 = 4(x - 3)^2$.
 Substituting into the equation for the circle results in $(x - 3)^2 + 4(x - 3)^2 = 20$.
- At this point, ask students to solve the equation for x and call on volunteers to share their results. Ask if students noticed that using the distributive property made solving the equation easier.
 $(x - 3)^2(1 + 4) = 20$
 $(x - 3)^2 = 4$ $x - 3 = 2$ or $x - 3 = -2$ $x = 5, 1$
- As expected, there are two possible values for x , 1 or 5. Why are two values expected?
 - There should be two lines tangent to a circle for any given slope.
- What are the coordinates of the points of tangency? How can you determine the y-coordinates?
 - $(1,1)$ and $(5,9)$; it is easiest to find the y-coordinate by plugging each x-coordinate into the slope formula above ($\frac{y-5}{x-3} = 2$).

- How can we verify that these two points lie on the circle?
 - *Substituting the coordinates into the equation given for the circle proves that they, in fact, do lie on the circle.*
- How can we find the equations of these tangent lines? What are the equations?
 - *We know both the slope and a point on each of the two tangent lines, so we can use the point-slope formula. The two equations are $y - 1 = -\frac{1}{2}(x - 1)$ and $y - 9 = -\frac{1}{2}(x - 5)$.*

Provide students time to discuss the process for finding the equations of the tangent lines; then, ask students how the solution would have changed if we were looking for two tangent lines whose slopes were 4 instead of $-\frac{1}{2}$. Students should respond that the slope of the radii to the tangent lines would change to $-\frac{1}{4}$, which would have impacted all other calculations related to slope and finding the equations.

Exercise 1 (5 minutes, optional)

The exercise below can be used to check for understanding of the process used to find the equations of tangent lines to circles. This exercise should be assigned to groups of students who struggled to respond to the last question from the previous discussion. Consider asking the question again—how would the solution have changed if the slopes of the tangent lines were $\frac{1}{3}$ instead of 2—after students finish work on Exercise 1. If this exercise is not used, Exercises 3–4 can be assigned at the end of the lesson.

Exercise 1

Consider the circle with equation $(x - 4)^2 + (y - 5)^2 = 20$. Find the equations of two tangent lines to the circle that each have slope 2.

$y - 7 = 2(x - 0)$ and $y - 3 = 2(x - 8)$

Example 2 (10 minutes)

Example 2

Refer to the diagram below.

Let $p > 1$. What is the equation of the tangent line to the circle $x^2 + y^2 = 1$ through the point $(p, 0)$ on the x -axis with a point of tangency in the upper half-plane?

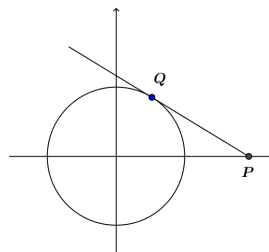

Scaffolding:

Consider labeling point Q as $(\frac{1}{2}, \frac{\sqrt{2}}{2})$ for struggling students. Ask them to show that the point does lie on the circle. Then, ask them to find the slope of the tangent line at that point.

- Use $Q(x, y)$ as the point of tangency, as shown in the diagram provided. Label the center as $O(0,0)$. What do we know about segments OP and OQ ?
 - *They are perpendicular.*

- Write an equation that considers this.
 - $\frac{y}{x} = \frac{x-p}{y-o}$ giving $x(x-p) + y^2 = 0$, or $x^2 - xp + y^2 = 0$
- Combine the two equations to find an expression for x .
 - Since $x^2 + y^2 = 1$, we get $1 - xp = 0$, or $x = \frac{1}{p}$.
- Use the expression for x to find an expression for y .
 - $y = \sqrt{1 - \frac{1}{p^2}}$ which simplifies to $y = \frac{1}{p}\sqrt{p^2 - 1}$.
- What are the coordinates of the point Q (the point of tangency)?
 - $(\frac{1}{p}, \frac{1}{p}\sqrt{p^2 - 1})$
- What is the slope of \overline{OQ} in terms of p ?
 - $\sqrt{p^2 - 1}$
- What is the slope of \overline{QP} in terms of p ?
 - $-\frac{1}{\sqrt{p^2 - 1}} = \frac{\sqrt{p^2 - 1}}{1 - p^2}$
- What is the equation of line QP ?
 - $y = \frac{\sqrt{p^2 - 1}}{1 - p^2}(x - p)$

Exercise 2 (3 minutes)

The following exercise continues the thinking that began in Example 2. Allow students to work on the exercise in pairs or small groups if necessary.

Exercises

2. Use the same diagram from Example 2 above, but label the point of tangency in the lower half-plane as Q' .

- a. What are the coordinates of Q' ?

$$(\frac{1}{p}, -\frac{1}{p}\sqrt{p^2 - 1})$$
- b. What is the slope of $\overline{OQ'}$?

$$-\sqrt{p^2 - 1}$$
- c. What is the slope of $\overline{Q'P}$?

$$\frac{\sqrt{p^2 - 1}}{p^2 - 1}$$
- d. Find the equation of the second tangent line to the circle through $(p, 0)$.

$$y = \frac{\sqrt{p^2 - 1}}{p^2 - 1}(x - p)$$

Discussion (4 minutes)

- As the point $(p, 0)$ on the x -axis slides to the right, that is, as we choose larger and larger values of p , to what coordinate pair does the point of tangency (Q) of the first tangent line (in Example 2) converge? Hint: It might be helpful to rewrite the coordinates of Q as $(\frac{1}{p}, \sqrt{1 - \frac{1}{p^2}})$.
 - $(0,1)$
- What is the equation of the tangent line in this limit case?
 - $y = 1$
- Suppose instead that we let the value of p be a value very close to $p = 1$. What can you say about the point of tangency and the tangent line to the circle in this case?
 - *The point of tangency would approach $(1,0)$, and the tangent line would have the equation $x = 1$.*
- For the case of $p = 2$, what angle does the tangent line make with the x -axis?
 - 30° ; *a right triangle is formed with base 1 and hypotenuse 2.*
- What value of p gives a tangent line intersecting the x -axis at a 45° angle?
 - *There is no solution that gives a 45° angle. If $p = 1$ (which results in the required number of degrees), then the tangent line is $x = 1$, which is perpendicular to the x -axis and, therefore, not at a 45° angle.*
- What is the length of \overline{QP} ?
 - $\sqrt{p^2 - 1}$ (Pythagorean theorem)

Exercises 3–4 (5 minutes)

The following two exercises can be completed in class, if time, or assigned as part of the problem set. Consider posing this follow up question to Exercise 4: How can we change the given equations so that they would represent lines tangent to the circle. Students should respond that the slope of the first equation should be $-\frac{4}{3}$ and the slope of the second equation should be $-\frac{3}{4}$.

3. Show that a circle with equation $(x - 2)^2 + (y + 3)^2 = 160$ has two tangent lines with equations $y + 15 = \frac{1}{3}(x - 6)$ and $y - 9 = \frac{1}{3}(x + 2)$.

Assume that the circle has the tangent lines given by the equations above. Then, the tangent lines have slope $\frac{1}{3}$, and the slope of the radius to those lines must be -3 . If we can show that the points $(6, -15)$ and $(-2, 9)$ are on the circle, and that the slope of the radius to the tangent lines is -3 , then we will have shown that the given circle has the two tangent lines given.

$$\begin{aligned} (6 - 2)^2 + (-15 + 3)^2 &= 4^2 + (-12)^2 \\ &= 16 + 144 \\ &= 160 \end{aligned}$$

$$\begin{aligned} (-2 - 2)^2 + (9 + 3)^2 &= (-4)^2 + 12^2 \\ &= 16 + 144 \\ &= 160 \end{aligned}$$

Since both points satisfy the equation, then the points $(6, -15)$ and $(-2, 9)$ are on the circle.

$$m = \frac{-15 - (-3)}{6 - 2} = -\frac{12}{4} = -3$$

$$m = \frac{9 - (-3)}{-2 - 2} = -\frac{12}{4} = -3$$

The slope of the radius is -3 .

MP.3

4. Could a circle given by the equation $(x - 5)^2 + (y - 1)^2 = 25$ have tangent lines given by the equations $y - 4 = \frac{4}{3}(x - 1)$ and $y - 5 = \frac{3}{4}(x - 8)$? Explain how you know.

Though the points $(1, 4)$ and $(8, 5)$ are on the circle, the given equations cannot represent tangent lines. For the equation $-4 = \frac{4}{3}(x - 1)$, the slope of the tangent line is $\frac{4}{3}$. To be tangent, the slope of the radius must be $-\frac{3}{4}$, but the slope of the radius is $\frac{3}{4}$; therefore, the equation does not represent a tangent line. Similarly, for the second equation, the slope is $\frac{3}{4}$; to be tangent to the circle, the radius must have slope $-\frac{4}{3}$, but the slope of the radius is $\frac{4}{3}$. Neither of the given equations represents lines that are tangent to the circle.

Closing (3 minutes)

Have students summarize the main points of the lesson in writing, by talking to a partner, or as a whole class discussion. Use the questions below, if necessary.

- Describe how to find the equations of lines that are tangent to a given circle.
- Describe how to find the equation of a tangent line given a circle and a point outside of the circle.

Lesson Summary

THEOREMS:

A tangent line to a circle is perpendicular to the radius of the circle drawn to the point of tangency.

Relevant Vocabulary

TANGENT TO A CIRCLE: A *tangent line to a circle* is a line in the same plane that intersects the circle in one and only one point. This point is called the *point of tangency*.

Exit Ticket (5 minutes)

Name _____

Date _____

Lesson 19: Equations for Tangent Lines to Circles

Exit Ticket

Consider the circle $(x + 2)^2 + (y - 3)^2 = 9$. There are two lines tangent to this circle having a slope of -1 .

1. Find the coordinates of the two points of tangency.

2. Find the equations of the two tangent lines.

Exit Ticket Sample Solutions

Consider the circle $(x + 2)^2 + (y - 3)^2 = 9$. There are two lines tangent to this circle having a slope of -1 .

1. Find the coordinates of the two points of tangency.

$$\left(\frac{3\sqrt{2}-4}{2}, \frac{3\sqrt{2}+6}{2}\right) \text{ and } \left(\frac{-3\sqrt{2}-4}{2}, \frac{-3\sqrt{2}+6}{2}\right) \text{ or } \sim(0.12, 5.12) \text{ and } (-4.12, 0.88)$$

2. Find the equations of the two tangent lines.

$$y - \frac{3\sqrt{2}+6}{2} = -\left(x - \frac{3\sqrt{2}-4}{2}\right) \text{ and } y - \frac{-3\sqrt{2}+6}{2} = -\left(x - \frac{-3\sqrt{2}-4}{2}\right) \text{ or } y - 5.12 = -(x - 0.12) \text{ and } y - 0.88 = -(x + 4.12)$$

Problem Set Sample Solutions

1. Consider the circle $(x - 1)^2 + (y - 2)^2 = 16$. There are two lines tangent to this circle having a slope of 0.

- a. Find the coordinates of the points of tangency.

$$(1, 6) \text{ and } (1, -2)$$

- b. Find the equations of the two tangent lines.

$$y = 6 \text{ and } y = -2$$

2. Consider the circle $x^2 - 4x + y^2 + 10y + 13 = 0$. There are two lines tangent to this circle having a slope of $\frac{2}{3}$.

- a. Find the coordinates of the two points of tangency.

$$\left(\frac{-8\sqrt{13}+26}{13}, \frac{12\sqrt{13}-65}{13}\right) \text{ and } \left(\frac{8\sqrt{13}+26}{13}, \frac{-12\sqrt{13}-65}{13}\right) \text{ or } \sim(-0.2, -1.7) \text{ and } (4.2, -8.3)$$

- b. Find the equations of the two tangent lines.

$$y - \frac{12\sqrt{13}-65}{13} = \frac{2}{3}\left(x + \frac{8\sqrt{13}+26}{13}\right) \text{ and } y + \frac{-12\sqrt{13}-65}{13} = \frac{2}{3}\left(x - \frac{8\sqrt{13}+26}{13}\right)$$

$$\text{or } y + 1.7 = \frac{2}{3}(x + 0.2) \text{ and } y + 8.3 = \frac{2}{3}(x - 4.2)$$

3. What are the coordinates of the points of tangency of the two tangent lines through the point $(1, 1)$ each tangent to the circle $x^2 + y^2 = 1$?

$$(0, 1) \text{ and } (1, 0)$$

4. What are the coordinates of the points of tangency of the two tangent lines through the point $(-1, -1)$ each tangent to the circle $x^2 + y^2 = 1$?

$$(0, -1) \text{ and } (-1, 0)$$

5. What is the equation of the tangent line to the circle $x^2 + y^2 = 1$ through the point $(6, 0)$?

$$y = -\frac{\sqrt{35}}{35}(x - 6)$$

6. D'Andre said that a circle with equation $(x - 2)^2 + (y - 7)^2 = 13$ has a tangent line represented by the equation $y - 5 = -\frac{3}{2}(x + 1)$. Is he correct? Explain.

Yes, D'Andre is correct. The point $(-1, 5)$ is on the circle, and the slopes are negative reciprocals.

7. Kamal gives the following proof that $y - 1 = \frac{8}{9}(x + 10)$ is the equation of a line that is tangent to a circle given by $(x + 1)^2 + (y - 9)^2 = 145$.

The circle has center $(-1, 9)$ and radius 12. The point $(-10, 1)$ is on the circle because

$$(-10 + 1)^2 + (1 - 9)^2 = (-9)^2 + (-8)^2 = 145.$$

The slope of the radius is $\frac{9-1}{-1-10} = \frac{8}{9}$; therefore, the equation of the tangent line is $y - 1 = \frac{8}{9}(x + 10)$.

- a. Kerry said that Kamal has made an error. What was Kamal's error? Explain what he did wrong.

Kamal used the slope of the radius as the slope of the tangent line. To be tangent, the slopes must be negative reciprocals of one another, not the same.

- b. What should the equation for the tangent line be?

$$y - 1 = -\frac{9}{8}(x + 10)$$

8. Describe a similarity transformation that maps a circle given by $x^2 + 6x + y^2 - 2y = 71$ to a circle of radius 3 that is tangent to both axes in the first quadrant.

The given circle has center $(-3, 1)$ and radius 9. A circle that is tangent to both axes in the first quadrant with radius 3 must have a center at $(3, 3)$. Then, a translation of $x^2 + 6x + y^2 - 2y = 71$ along a vector from $(-3, 1)$ to $(3, 3)$, and a dilation by a scale factor of $\frac{1}{3}$ from the center $(3, 3)$ will map circle $x^2 + 6x + y^2 - 2y = 71$ onto the circle in the first quadrant with radius 3.

MP.3



Topic E:

Cyclic Quadrilaterals and Ptolemy's Theorem

G-C.A.3

Focus Standard:	G-C.A.3	Construct the inscribed and circumscribed circles of a triangle, and prove properties of angles for a quadrilateral inscribed in a circle.
Instructional Days:	2	
	Lesson 20:	Cyclic Quadrilaterals (P) ¹
	Lesson 21:	Ptolemy's Theorem (E)

Topic E is a two lesson topic recalling several concepts from the year, e.g., Pythagorean theorem, similarity, and trigonometry, as well as concepts from Module 5 related to arcs and angles. In Lesson 20, students are introduced to the term *cyclic quadrilaterals* and define the term informally as a quadrilateral whose vertices lie on a circle. Students then prove that a quadrilateral is cyclic if and only if the opposite angles of the quadrilateral are supplementary. They use this reasoning and the properties of quadrilaterals inscribed in circles (**G-C.A.3**) to develop the area formula for a cyclic quadrilateral in terms of side length. Lesson 21 continues the study of cyclic quadrilaterals as students prove Ptolemy's theorem and understand that the area of a cyclic quadrilateral is a function of its side lengths and an acute angle formed by its diagonals (**G-SRT.D.9**). Students must identify features within complex diagrams to inform their thinking, highlighting MP.7. For example, students use the structure of an inscribed triangle in a half-plane separated by the diagonal of a cyclic quadrilateral to conclude that a reflection of the triangle along the diagonal produces a different cyclic quadrilateral with an area equal to the original cyclic quadrilateral. Students use this reasoning to make sense of Ptolemy's theorem and its origin.

¹ Lesson Structure Key: P-Problem Set Lesson, M-Modeling Cycle Lesson, E-Exploration Lesson, S-Socratic Lesson



Lesson 20: Cyclic Quadrilaterals

Student Outcomes

- Students show that a quadrilateral is cyclic if and only if its opposite angles are supplementary.
- Students derive and apply the area of cyclic quadrilateral $ABCD$ as $\frac{1}{2}AC \cdot BD \cdot \sin(w)$, where w is the measure of the acute angle formed by diagonals AC and BD .

Lesson Notes

In Lessons 20 and 21, students experience a culmination of the skills they learned in the previous lessons and modules to reveal and understand powerful relationships that exist among the angles, chord lengths, and areas of cyclic quadrilaterals. Students will apply reasoning with angle relationships, similarity, trigonometric ratios and related formulas, and relationships of segments intersecting circles. They begin exploring the nature of cyclic quadrilaterals and use the lengths of the diagonals of cyclic quadrilaterals to determine their area. Next, students construct the circumscribed circle on three vertices of a quadrilateral (a triangle) and use angle relationships to prove that the fourth vertex must also lie on the circle (**G-C.A.3**). They then use these relationships and their knowledge of similar triangles and trigonometry to prove Ptolemy's theorem, which states that the product of the lengths of the diagonals of a cyclic quadrilateral is equal to the sum of the products of the lengths of the opposite sides of the cyclic quadrilateral.

Classwork

Opening (5 minutes)

Students first encountered a cyclic quadrilateral in Lesson 5, Exercise 1, part (a), though it was referred to simply as an inscribed polygon. Begin the lesson by discussing the meaning of a *cyclic quadrilateral*.

- Quadrilateral $ABCD$ shown in the Opening Exercise is an example of a *cyclic quadrilateral*. What do you believe the term cyclic means in this case?
 - *The vertices A , B , C , and D lie on a circle.*
- Discuss the following question with a shoulder partner and then share out: What is the relationship of x and y in the diagram?
 - *x and y must be supplementary since they are inscribed in two adjacent arcs that form a complete circle.*

Make a clear statement to students that a cyclic quadrilateral is a quadrilateral that is inscribed in a circle.

Opening Exercise (5 minutes)

MP.7

Opening Exercise

Given cyclic quadrilateral $ABCD$ shown in the diagram, prove that $x + y = 180^\circ$.

Statements	Reasons/Explanations
1. $(m\widehat{BCD}) + (m\widehat{DAB}) = 360^\circ$	1. Arc \widehat{BCD} and arc \widehat{DAB} are non-overlapping arcs that form a complete circle.
2. $\frac{1}{2} [(m\widehat{BCD}) + (m\widehat{DAB})] = \frac{1}{2} (360^\circ)$	2. Multiplicative property of equality
3. $\frac{1}{2} (m\widehat{BCD}) + \frac{1}{2} (m\widehat{DAB}) = 180^\circ$	3. Distributive property
4. $x = \frac{1}{2} (m\widehat{BCD})$ and $y = \frac{1}{2} (m\widehat{DAB})$	4. Inscribed angle theorem
5. $x + y = 180^\circ$	5. Substitution

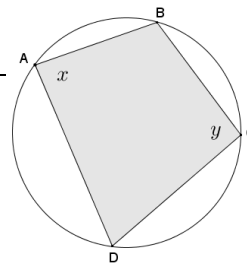

Example 1 (7 minutes)

Pose the question below to students before starting Example 1, and ask them to hypothesize their answers.

- The Opening Exercise shows that if a quadrilateral is cyclic, then its opposite angles are supplementary. Let's explore the converse relationship. If a quadrilateral has supplementary opposite angles, is the quadrilateral necessarily a cyclic quadrilateral?
 - Yes.
- How can we show that your hypothesis is valid?
 - *Student answers will vary.*

Scaffolding:

- Remind students that a triangle can be inscribed in a circle or a circle can be circumscribed about a triangle. This allows us to draw a circle on three of the four vertices of the quadrilateral. It is our job to show that the fourth vertex also lies on the circle.
- Have students create cyclic quadrilaterals and measure angles to see patterns. This will support concrete work.
- Explain proof by contradiction by presenting a simple proof such as 2 points define a line, and have students try to prove this is not true.

Example 1

Given quadrilateral $ABCD$ with $m\angle A + m\angle C = 180^\circ$, prove that quadrilateral $ABCD$ is cyclic; in other words, prove that points A , B , C , and D lie on the same circle.

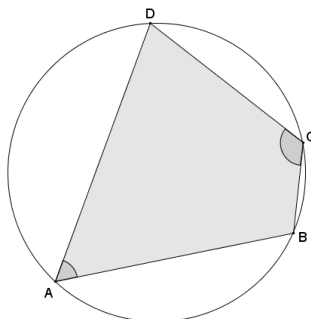

MP.7

- First, we are given that angles A and C are supplementary. What does this mean about angles B and D , and why?
 - *The angle sum of a quadrilateral is 360° , and since it is given that angles A and C are supplementary, angles B and D must then have a sum of 180° .*
- We, of course, can draw a circle through point A , and we can further draw a circle through points A and B (infinitely many circles, actually). Can we draw a circle through points A , B , and C ?
 - *Three non-collinear points can determine a circle, and since the points were given to be vertices of a quadrilateral, the points are non-collinear; so, yes!*
- Can we draw a circle through points A , B , C , and D ?
 - *Not all quadrilaterals are cyclic (e.g., a non-rectangular parallelogram), so we cannot assume that a circle can be drawn through vertices A , B , C , and D .*
- Where could point D lie in relation to the circle?
 - *D could lie on the circle, in the interior of the circle, or on the exterior of the circle.*
- To show that D lies on the circle with A , B , and C , we need to consider the cases where it is not, and show that those cases are impossible. First, let's consider the case where D is outside the circle. On the diagram, use a red pencil to locate and label point D' such that it is outside the circle; then, draw segments CD' and AD' .
- What do you notice about sides AD' and CD' if vertex D' is outside the circle?
 - *The sides intersect the circle and are, therefore, secants.*

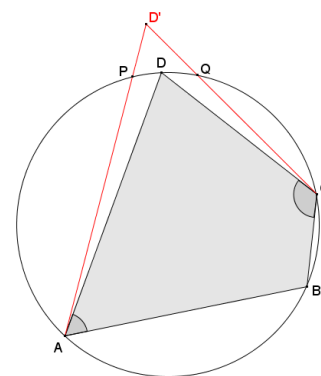

Statements	Reasons/Explanations
1. $m\angle A + m\angle C = 180^\circ$	1. <i>Given</i>
2. <i>Assume point D' lies outside the circle determined by points A, B, and C.</i>	2. <i>Stated assumption for case 1.</i>
3. <i>Segments CD' and AD' intersect the circle at distinct points P and Q; thus, $m\widehat{PQ} > 0^\circ$.</i>	3. <i>If the segments intersect the circle at the same point, then D' lies on the circle, and the stated assumption (Statement 2) is false.</i>
4. $m\angle D' = \frac{1}{2}(m\widehat{ABC} - m\widehat{PQ})$	4. <i>Secant angle theorem: exterior case</i>
5. $m\angle B = \frac{1}{2}(m\widehat{APC})$	5. <i>Inscribed angle theorem</i>
6. $m\angle A + m\angle B + m\angle C + m\angle D' = 360^\circ$	6. <i>The angle sum of a quadrilateral is 360°.</i>
7. $m\angle B + m\angle D' = 180^\circ$	7. <i>Substitution (Statements 1 and 6)</i>
8. $\frac{1}{2}(m\widehat{APC}) + \frac{1}{2}(m\widehat{ABC} - m\widehat{PQ}) = 180^\circ$	8. <i>Substitution (Statements 4, 5, and 7)</i>
9. $360^\circ - m\widehat{APC} = m\widehat{ABC}$	9. <i>Arcs \widehat{APC} and \widehat{ABC} are non-overlapping arcs that form a complete circle with a sum of 360°.</i>
10. $\frac{1}{2}(m\widehat{APC}) + \frac{1}{2}((360^\circ - m\widehat{APC}) - m\widehat{PQ}) = 180^\circ$	10. <i>Substitution (Statements 8 and 9)</i>
11. $\frac{1}{2}(m\widehat{APC}) + 180^\circ - \frac{1}{2}(m\widehat{APC}) - m\widehat{PQ} = 180^\circ$	11. <i>Distributive property</i>
12. $m\widehat{PQ} = 0^\circ$	12. <i>Subtraction property of equality</i>
13. <i>D' cannot lie outside the circle.</i>	13. <i>Statement 12 contradicts our stated assumption that P and Q are distinct with $m\widehat{PQ} > 0^\circ$ (Statement 3).</i>

Exercise 1 (5 minutes)

Students use a similar strategy to show that vertex D cannot lie inside the circle.

Exercises	
<p>1. Assume that vertex D'' lies inside the circle as shown in the diagram. Use a similar argument to Example 1 to show that vertex D'' cannot lie inside the circle.</p>	
Statements	Reasons/Explanations
1. $m\angle A + m\angle C = 180^\circ$	1. <i>Given</i>
2. Assume point D'' lies inside the circle determined by points A , B , and C .	2. <i>Stated assumption for case 2</i>
3. $\overline{CD''}$ and $\overline{AD''}$ intersect the circle at points P and Q respectively, thus $m\widehat{PQ} > 0$.	3. <i>If the segments intersect the circle at the same point, then D'' lies on the circle, and the stated assumption (Statement 2) is false.</i>
4. $m\angle D'' = \frac{1}{2}(m\widehat{PQ} + m\widehat{ABC})$	4. <i>Secant angle theorem: interior case</i>
5. $m\angle B = \frac{1}{2}(m\widehat{APC})$	5. <i>Inscribed angle theorem</i>
6. $m\angle A + m\angle B + m\angle C + m\angle D'' = 360^\circ$	6. <i>The angle sum of a quadrilateral is 360°.</i>
7. $m\angle B + m\angle D'' = 180^\circ$	7. <i>Substitution (Statements 1 and 6)</i>
8. $\frac{1}{2}(m\widehat{APC}) + \frac{1}{2}(m\widehat{PQ} + m\widehat{ABC}) = 180^\circ$	8. <i>Substitution (Statements 4, 5, and 7)</i>
9. $m\widehat{ABC} = 360^\circ - m\widehat{APC}$	9. <i>Arcs \widehat{APC} and \widehat{ABC} are non-overlapping arcs that form a complete circle with a sum of 360°.</i>
10. $\frac{1}{2}(m\widehat{APC}) + \frac{1}{2}(m\widehat{PQ} + (360^\circ - m\widehat{APC})) = 180^\circ$	10. <i>Substitution (Statements 8 and 9)</i>
11. $\frac{1}{2}(m\widehat{APC}) + \frac{1}{2}(m\widehat{PQ}) + 180^\circ - \frac{1}{2}(m\widehat{APC}) = 180^\circ$	11. <i>Distributive property</i>
12. $m\widehat{PQ} = 0^\circ$	12. <i>Subtraction property of equality</i>
13. D'' cannot lie inside the circle.	13. <i>Statement 12 contradicts our stated assumption that P and Q are distinct with $m\widehat{PQ} > 0^\circ$ (Statement 3).</i>

- In Example 1 and Exercise 1, we showed that the fourth vertex D cannot lie outside the circle or inside the circle. What conclusion does this leave us with?
 - *The fourth vertex must then lie on the circle with points A , B , and C .*

- In the Opening Exercise, you showed that the opposite angles in a cyclic quadrilateral are supplementary. In Example 1 and Exercise 1, we showed that if a quadrilateral has supplementary opposite angles, then the vertices must lie on a circle. This confirms the following theorem:

THEOREM: A quadrilateral is cyclic if and only if its opposite angles are supplementary.

- Take a moment to discuss with a shoulder partner what this theorem means and how we can use it.
 - Answers will vary.

Exercises 2–3 (5 minutes)

Students now apply the theorem about cyclic quadrilaterals.

2. Quadrilateral $PQRS$ is a cyclic quadrilateral. Explain why $\triangle PQT \sim \triangle SRT$.

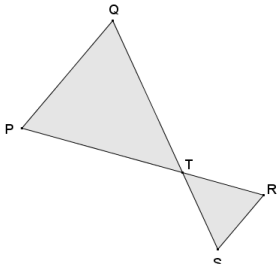

If $PQRS$ is a cyclic quadrilateral, draw circle on points $P, Q, R,$ and S . Then $\angle PQS$ and $\angle PRS$ are angles inscribed in the same arc \widehat{SP} ; therefore, they are equal in measure. Also, $\angle QPR$ and $\angle QSR$ are both inscribed in the same arc \widehat{QR} ; therefore, they are equal in measure. Therefore, by AA criterion for similar triangles, $\triangle PQT \sim \triangle SRT$.

(Students may also use vertical angles relationship at T .)

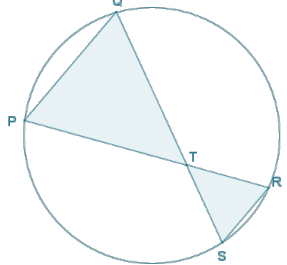

3. A cyclic quadrilateral has perpendicular diagonals. What is the area of the quadrilateral in terms of $a, b, c,$ and d as shown?

Using the area formula for a triangle Area = base · height, the area of the quadrilateral is the sum of the areas of the four right triangular regions.

$$\text{Area} = \frac{1}{2}ac + \frac{1}{2}cb + \frac{1}{2}bd + \frac{1}{2}da$$

OR

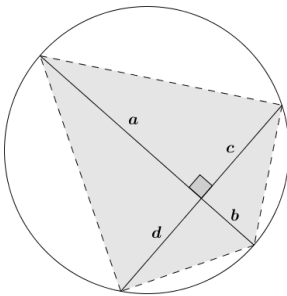
$$\text{Area} = \frac{1}{2}(ac + cb + bd + da)$$

Discussion (5 minutes)

Redraw the cyclic quadrilateral from Exercise 3 as shown in diagram to the right.

- How does this diagram relate to the area(s) that you found in Exercise 3 in terms of $a, b, c,$ and d ?
 - Each right triangular region in the cyclic quadrilateral is half of a rectangular region. The area of the quadrilateral is the sum of the areas of the triangles, and also half the area of the sum of the four smaller rectangular regions.

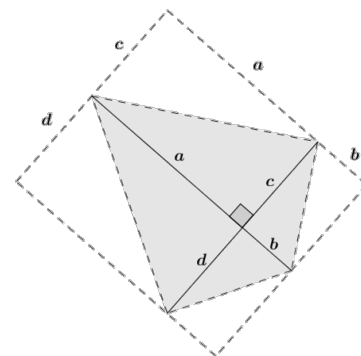

- What are the lengths of the sides of the large rectangle?
 - *The lengths of the sides of the large rectangle are $a + b$ and $c + d$.*
- Using the lengths of the large rectangle, what is its area?
 - $Area = (a + b)(c + d)$
- How is the area of the given cyclic quadrilateral related to the area of the large rectangle?
 - *The area of the cyclic quadrilateral is $\frac{1}{2}[(a + b)(c + d)]$.*
- What does this say about the area of a cyclic quadrilateral with perpendicular diagonals?
 - *The area of a cyclic quadrilateral with perpendicular diagonals is equal to one-half the product of the lengths of its diagonals.*
- Can we extend this to other cyclic quadrilaterals (for instance, cyclic quadrilaterals whose diagonals intersect to form an acute angle w°)? Discuss this question with a shoulder partner before beginning Example 2.

Exercises 4–5 (Optional, 5 minutes)

These exercises may be necessary for review of the area of a non-right triangle using one acute angle. You may assign these as an additional problem set to the previous lesson because the skills have been taught before. If students demonstrate confidence with the content, go directly to Exercise 6.

4. Show that the triangle in the diagram has area $\frac{1}{2} ab \sin(w)$.

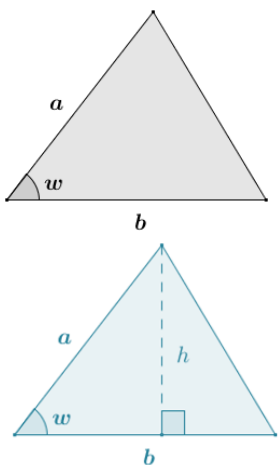

Draw altitude to side with length b as shown in the diagram to form adjacent right triangles. Using right triangle trigonometry, the sine of the acute angle with degree measure w is:

$\sin w = \frac{h}{a}$ where h is the length of the altitude to side b .

It then follows that $h = a \sin w$.

Using the area formula for a triangle $Area = \frac{1}{2} \times \text{base} \times \text{height}$:

$Area = \frac{1}{2} b(a \sin(w))$

$Area = \frac{1}{2} ab \sin(w)$

5. Show that the triangle with obtuse angle $(180 - w)^\circ$ has area $\frac{1}{2} ab \sin(w)$.

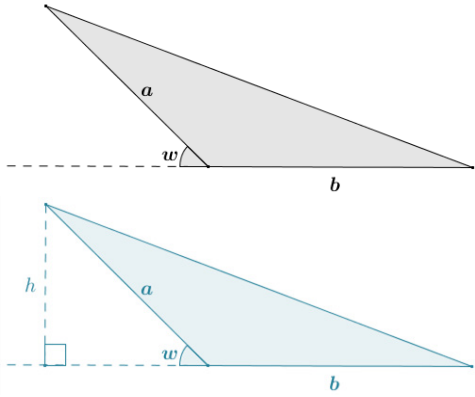

Draw altitude to the line that includes the side of the triangle with length b . Using right triangle trigonometry:

$$\sin(w) = \frac{h}{a} \text{ where } h \text{ is the length of the altitude drawn.}$$

It follows then that $h = a \sin(w)$.

Using the area formula for a triangle

$$\text{Area} = \frac{1}{2} \times \text{base} \times \text{height:}$$

$$\text{Area} = \frac{1}{2} b(a \sin(w))$$

$$\text{Area} = \frac{1}{2} ab \sin(w)$$

Exercise 6 (5 minutes)

Students in pairs apply the area formula $\text{Area} = \frac{1}{2} ab \sin(w)$, first encountered in Lesson 31 of Module 2, to show that the area of a cyclic quadrilateral is one-half the product of the lengths of its diagonals and the sine of the acute angle formed by their intersection.

6. Show that the area of the cyclic quadrilateral shown in the diagram is $\text{Area} = \frac{1}{2} (a + b)(c + d) \sin(w)$.

Using the area formula for a triangle $\text{Area} = \frac{1}{2} ab \cdot \sin(w)$:

$$\text{Area}_1 = \frac{1}{2} ad \cdot \sin(w)$$

$$\text{Area}_2 = \frac{1}{2} ac \cdot \sin(w)$$

$$\text{Area}_3 = \frac{1}{2} bc \cdot \sin(w)$$

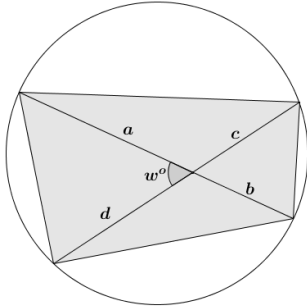
$$\text{Area}_4 = \frac{1}{2} bd \cdot \sin(w)$$

$$\text{Area}_{\text{total}} = \text{Area}_1 + \text{Area}_2 + \text{Area}_3 + \text{Area}_4$$

$$\text{Area}_{\text{total}} = \frac{1}{2} ad \cdot \sin(w) + \frac{1}{2} ac \cdot \sin(w) + \frac{1}{2} bc \cdot \sin(w) + \frac{1}{2} bd \cdot \sin(w)$$

$$\text{Area}_{\text{total}} = \left[\frac{1}{2} \sin(w) \right] (ad + ac + bc + bd)$$

$$\text{Area}_{\text{total}} = \left[\frac{1}{2} \sin(w) \right] [(a + b)(c + d)]$$

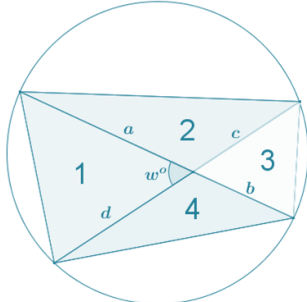
$$\text{Area}_{\text{total}} = \frac{1}{2} (a + b)(c + d) \sin(w)$$

Closing (3 minutes)

Ask students to verbally provide answers to the following closing questions based on the lesson:

- What angle relationship exists in any cyclic quadrilateral?
 - *Both pairs of opposite angles are supplementary.*
- If a quadrilateral has one pair of opposite angles supplementary, does it mean that the quadrilateral is cyclic? Why?
 - *Yes. We proved that if the opposite angles of a quadrilateral are supplementary, then the fourth vertex of the quadrilateral must lie on the circle through the other three vertices.*
- Describe how to find the area of a cyclic quadrilateral using its diagonals.
 - *The area of a cyclic quadrilateral is one-half the product of the lengths of the diagonals and the sine of the acute angle formed at their intersection.*

Lesson Summary**THEOREMS:**

Given a convex quadrilateral, the quadrilateral is cyclic if and only if one pair of opposite angles is supplementary.

The area of a triangle with side lengths a and b and acute included angle with degree measure w :

$$\text{Area} = \frac{1}{2}ab \cdot \sin(w).$$

The area of a cyclic quadrilateral $ABCD$ whose diagonals \overline{AC} and \overline{BD} intersect to form an acute or right angle with degree measure w :

$$\text{Area}(ABCD) = \frac{1}{2} \cdot AC \cdot BD \cdot \sin(w).$$

Relevant Vocabulary

CYCLIC QUADRILATERAL: A quadrilateral inscribed in a circle is called a *cyclic quadrilateral*.

Exit Ticket (5 minutes)

Name _____

Date _____

Lesson 20: Cyclic Quadrilaterals

Exit Ticket

1. What value of x guarantees that the quadrilateral shown in the diagram below is cyclic? Explain.

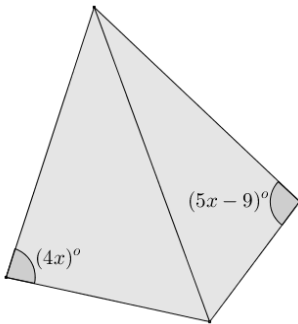

2. Given quadrilateral $GKHJ$, $m\angle KGJ + m\angle KHJ = 180^\circ$, $m\angle HNJ = 60^\circ$, $KN = 4$, $NJ = 48$, $GN = 8$, and $NH = 24$, find the area of quadrilateral $GKHJ$. Justify your answer.

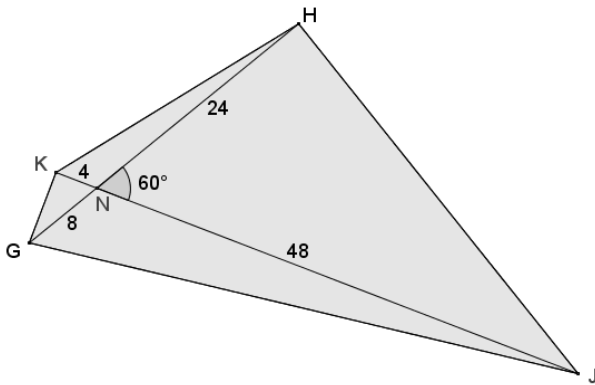

Exit Ticket Sample Solutions

1. What value of x guarantees that the quadrilateral shown in the diagram below is cyclic? Explain.

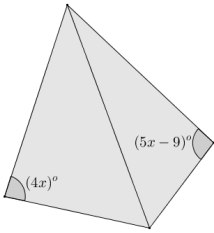

$$4x + 5x - 9 = 180$$

$$9x - 9 = 180$$

$$9x = 189$$

$$x = 21$$

If $x = 21$, then the opposite angles shown are supplementary, and any quadrilateral with supplementary opposite angles is cyclic.

2. Given quadrilateral $GKHJ$, $m\angle KGJ + m\angle KHJ = 180^\circ$, $m\angle HNJ = 60^\circ$, $KN = 4$, $NJ = 48$, $GN = 8$, and $NH = 24$, find the area of quadrilateral $GKHJ$. Justify your answer.

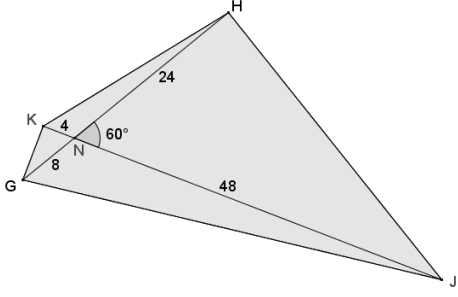

Opposite angles KGJ and KHJ are supplementary, so quadrilateral $GKHJ$ is cyclic.

The area of a cyclic quadrilateral:

$$\text{Area} = \frac{1}{2}(4 + 48)(8 + 24) \cdot \sin(60)$$

$$\text{Area} = \frac{1}{2}(52)(32) \cdot \frac{\sqrt{3}}{2}$$

$$\text{Area} = \frac{\sqrt{3}}{4} \cdot 1664$$

$$\text{Area} = 416\sqrt{3}$$

The area of quadrilateral $GKHJ$ is $416\sqrt{3}$ square units.

Problem Set Sample Solutions

The problems in this Problem Set get progressively more difficult and require use of recent and prior skills. The length of the Problem Set may be too time consuming for students to complete in its entirety. Problems 10–12 are the most difficult and may be passed over, especially for struggling students.

1. Quadrilateral $BDCE$ is cyclic, O is the center of the circle, and $m\angle BOC = 130^\circ$. Find $m\angle BEC$.

By the inscribed angle theorem, $m\angle BDC = \frac{1}{2}m\angle BOC$, so $m\angle BDC = 65^\circ$.

Opposite angles of cyclic quadrilaterals are supplementary, so $m\angle BEC + 65^\circ = 180^\circ$. Thus, $m\angle BEC = 115^\circ$.

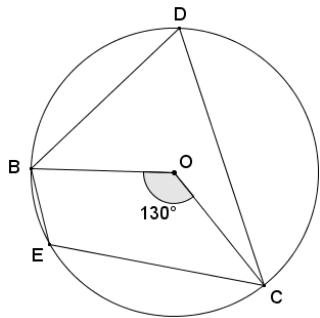

2. Quadrilateral $FAED$ is cyclic, $AX = 8$, $FX = 6$, $XD = 3$, and $m\angle AXE = 130^\circ$. Find the area of quadrilateral $FAED$.

Using the two-chord power rule, $(AX)(XD) = (FX)(XE)$.

$$8(3) = 6(XE), \text{ thus } XE = 4.$$

The area of a cyclic quadrilateral is equal to the product of the lengths of the diagonals and the sine of the acute angle formed by them. The acute angle formed by the diagonals is 50° .

$$\text{Area} = (8 + 3)(6 + 4) \cdot \sin(50)$$

$$\text{Area} = (11)(10) \cdot \sin(50)$$

$$\text{Area} \approx 84.3$$

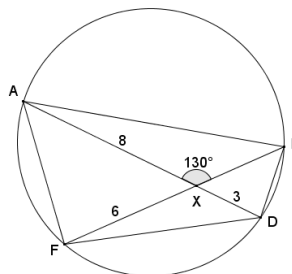

3. In the diagram below, $\overline{BE} \parallel \overline{CD}$, and $m\angle BED = 72^\circ$. Find the value of s and t .

Quadrilateral $BCDE$ is cyclic, so opposite angles are supplementary.

$$s + 72^\circ = 180^\circ$$

$$s = 108^\circ$$

Parallel chords BE and CD intercept congruent arcs \widehat{CB} and \widehat{ED} . By angle addition, $m\widehat{CBE} = m\widehat{BED}$, so it follows by the inscribed angle theorem that $s = t = 108^\circ$.

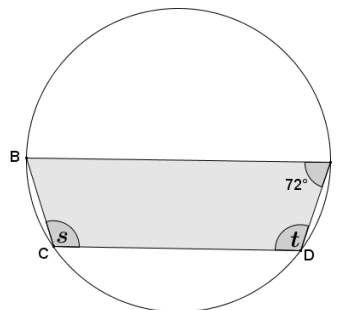

4. In the diagram below, \overline{BC} is the diameter, $m\angle BCD = 25^\circ$, and $\overline{CE} \cong \overline{DE}$. Find $m\angle CED$.

Triangle BCD is inscribed in a semicircle. By Thales' theorem, $\angle BDC$ is a right angle. By the angle sum of a triangle, $m\angle DBC = 65^\circ$. Quadrilateral $BCED$ is cyclic, so opposite angles are supplementary.

$$65^\circ + m\angle CED = 180^\circ$$

$$m\angle CED = 115^\circ$$

Triangle CED is isosceles since $\overline{CE} \cong \overline{DE}$, and by base \angle 's, $\angle EDC \cong \angle ECD$.

$$2(m\angle EDC) = 180^\circ - 115^\circ, \text{ by the angle sum of a triangle.}$$

$$m\angle EDC = 32.5^\circ$$

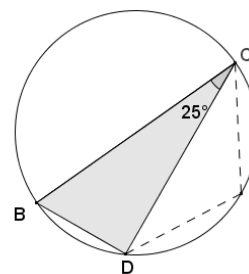

5. In circle A , $m\angle ABD = 15^\circ$. Find $m\angle BCD$.

Draw diameter \overline{BAX} such that X is on the circle, then draw \overline{DX} . Triangle BDX is inscribed in a semicircle; therefore, angle BDX is a right angle. By the angle sum of a triangle, $m\angle BXD = 75^\circ$.

Quadrilateral $BCDX$ is a cyclic quadrilateral, so its opposite angles are supplementary.

$$m\angle BCD + m\angle BXD = 180^\circ$$

$$m\angle BCD + 75^\circ = 180^\circ$$

$$m\angle BCD = 105^\circ$$

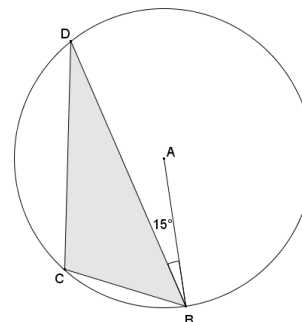

6. Given the diagram below, O is the center of the circle. If $m\angle NOP = 112^\circ$, find $m\angle PQE$.

Draw point X on major arc \widehat{NP} , and draw chords \overline{XN} and \overline{XP} to form cyclic quadrilateral $QNX P$. By the inscribed angle theorem, $m\angle NXP = \frac{1}{2}m\angle NOP$, so $m\angle NXP = 56^\circ$.

An exterior angle PQE of cyclic quadrilateral $QNX P$ is equal in measure to the angle opposite from vertex Q , which is $\angle NXP$. Therefore, $m\angle PQE = 56^\circ$.

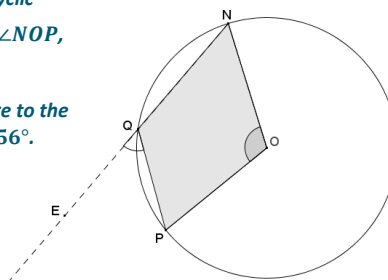

7. Given the angle measures as indicated in the diagram below, prove that vertices $C, B, E,$ and D lie on a circle.

Using the angle sum of a triangle, $m\angle FBE = 43^\circ$. Angles GBC and FBE are vertical angles and, therefore, have the same measure. Angles GBF and EBC are also vertical angles and have the same measure. Angles at a point sum to 360° , so $m\angle CBE = m\angle FBG = 137^\circ$. Since $137 + 43 = 180$, angles EBC and EDC of quadrilateral $BCDE$ are supplementary. If a quadrilateral has opposite angles that are supplementary, then the quadrilateral is cyclic, which means that vertices $C, B, E,$ and D lie on a circle.

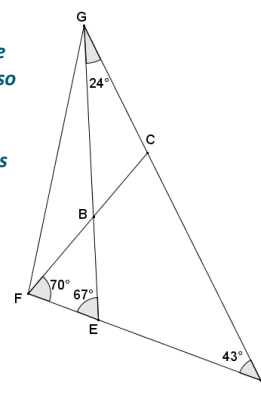

8. In the diagram below, quadrilateral $JKLM$ is cyclic. Find the value of n .

Angles HKJ and LKJ form a linear pair and are supplementary, so angle LKJ has measure of 98° .

Opposite angles of a cyclic quadrilateral are supplementary; thus, $m\angle JML = m\angle JKH = 82^\circ$.

Angles JML and IML form a linear pair and are supplementary, so angle IML has measure of 98° . Therefore, $n = 98$.

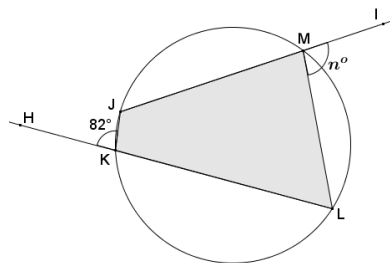

9. Do all four perpendicular bisectors of the sides of a cyclic quadrilateral pass through a common point? Explain.

Yes. A cyclic quadrilateral has vertices that lie on a circle, which means that the vertices are equidistant from the center of the circle. The perpendicular bisector of a segment is the set of points equidistant from the segment's endpoints. Since the center of the circle is equidistant from all of the vertices (endpoints of the segments that make up the sides of the cyclic quadrilateral), the center lies on all four perpendicular bisectors of the quadrilateral.

10. The circles in the diagram below intersect at points A and B . If $m\angle FHG = 100^\circ$ and $m\angle HGE = 70^\circ$, find $m\angle GEF$ and $m\angle EFH$.

Quadrilaterals $GHBA$ and $EFBA$ are both cyclic since their vertices lie on circles. Opposite angles in cyclic quadrilaterals are supplementary.

$$m\angle GAB + m\angle FHG = 180^\circ$$

$$m\angle GAB + 100^\circ = 180^\circ$$

$$m\angle GAB = 80^\circ$$

$\angle EAB$ and $\angle GAB$ are supplementary since they form a linear pair, so $m\angle EAB = 100^\circ$.

$\angle EAB$ and $\angle EFB$ are supplementary since they are opposite angles in a cyclic quadrilateral, so $m\angle EFB = 80^\circ$.

Using a similar argument:

$$m\angle HGE + m\angle HBA = m\angle HBA + m\angle FBA = m\angle FBA + m\angle GEF = 180^\circ$$

$$m\angle HGE + m\angle HBA = m\angle HBA + m\angle FBA = m\angle FBA + m\angle GEF = 180^\circ$$

$$m\angle HGE + m\angle GEF = 180^\circ$$

$$70^\circ + m\angle GEF = 180^\circ$$

$$m\angle GEF = 110^\circ$$

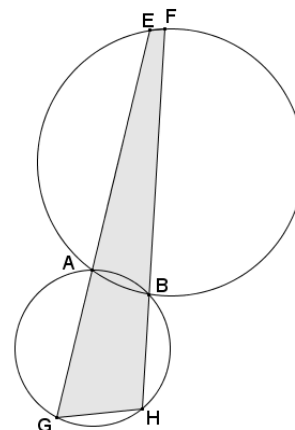

11. A quadrilateral is called *bicentric* if it is both cyclic and possesses an inscribed circle. (See diagram to the right.)

- a. What can be concluded about the opposite angles of a bicentric quadrilateral? Explain.

Since a bicentric quadrilateral must be also cyclic, its opposite angles must be supplementary.

- b. Each side of the quadrilateral is tangent to the inscribed circle. What does this tell us about the segments contained in the sides of the quadrilateral?

Two tangents to a circle from an exterior point form congruent segments. The distances from a vertex of the quadrilateral to the tangent points where it meets the inscribed circle are equal.

- c. Based on the relationships highlighted in part (b), there are four pairs of congruent segments in the diagram. Label segments of equal length with a , b , c , and d .

See diagram on the right.

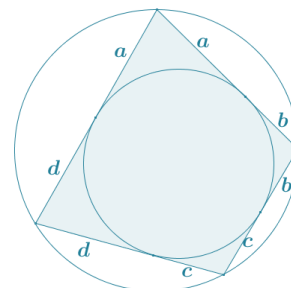
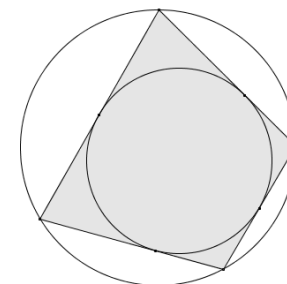

- d. What do you notice about the opposite sides of the bicentric quadrilateral?

The sum of the lengths of one pair of opposite sides of the bicentric quadrilateral is equal to the sum of the lengths of the other pair of opposite sides:

$$(a + b) + (c + d) = (d + a) + (b + c).$$

12. Quadrilateral $PSRQ$ is cyclic such that \overline{PQ} is the diameter of the circle. If $\angle QRT \cong \angle QSR$, prove that $\angle PTR$ is a right angle, and show that S, X, T , and P lie on a circle.

Angles RQX and SQR are congruent since they are the same angle. Since it was given that $\angle QRT \cong \angle QSR$, it follows that $\triangle QXR \sim \triangle QRS$ by AA similarity criterion. Corresponding angles in similar figures are congruent, so $\angle QRS \cong \angle QXR$, and by vert. \angle 's, $\angle QXR \cong \angle TXS$.

Quadrilateral $PSRQ$ is cyclic, so its opposite angles QPS and QRS are supplementary. Since $\angle QXR \cong \angle TXS$, it follows that angles TXS and QPS are supplementary. If a quadrilateral has a pair of opposite angles that are supplementary, then the quadrilateral is cyclic. Thus, quadrilateral $SXTP$ is cyclic.

Angle PSQ is a right angle since it is inscribed in a semi-circle. If a quadrilateral is cyclic, then its opposite angles are supplementary; thus, angle PTR must be supplementary to angle PSQ . Therefore, it is a right angle.

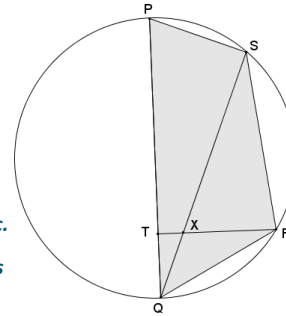



Lesson 21: Ptolemy's Theorem

Student Outcomes

- Students determine the area of a cyclic quadrilateral as a function of its side lengths and the acute angle formed by its diagonals.
- Students prove *Ptolemy's theorem*, which states that for a cyclic quadrilateral $ABCD$, $AC \cdot BD = AB \cdot CD + BC \cdot AD$. They explore applications of the result.

Lesson Notes

In this lesson, students work to understand Ptolemy's theorem, which says that for a cyclic quadrilateral D , $AC \cdot BD = AB \cdot CD + BC \cdot AD$. As such, this lesson focuses on the properties of quadrilaterals inscribed in circles. Ptolemy's single result and the proof for it codify many geometric facts; for instance, the Pythagorean theorem (**G-GPE.A.1**, **G-GPE.B.4**), area formulas, and trigonometry results. Therefore, it serves as a capstone experience to our year-long study of geometry. Students will use the area formulas they established in the previous lesson to prove the theorem. A set square, patty paper, compass, and straight edge are needed to complete the Exploratory Challenge.

Classwork

Opening (2 minutes)

The Pythagorean theorem, credited to the Greek mathematician Pythagoras of Samos (ca. 570–ca. 495 BCE), describes a universal relationship among the sides of a right triangle. Every right triangle (in fact every triangle) can be circumscribed by a circle. Six centuries later, Greek mathematician Claudius Ptolemy (ca. 90–ca. 168 CE) discovered a relationship between the side-lengths and the diagonals of any quadrilateral inscribed in a circle. As we shall see, Ptolemy's result can be seen as an extension of the Pythagorean theorem.

Opening Exercise (5 minutes)

Students are given the statement of Ptolemy's theorem and are asked to test the theorem by measuring lengths on specific cyclic quadrilaterals they are asked to draw. Students conduct this work in pairs and then gather to discuss their ideas afterwards in class as a whole.

Opening Exercise

Ptolemy's theorem says that for a cyclic quadrilateral $ABCD$, $AC \cdot BD = AB \cdot CD + BC \cdot AD$.

With ruler and a compass, draw an example of a cyclic quadrilateral. Label its vertices A , B , C , and D .

Draw the two diagonals \overline{AC} and \overline{BD} .

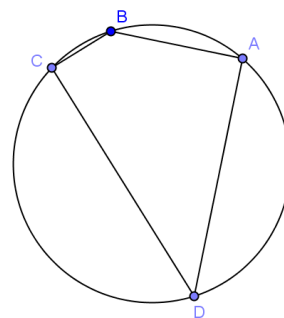

MP.7

With a ruler, test whether or not the claim that $AC \cdot BD = AB \cdot CD + BC \cdot AD$ seems to hold true.

Repeat for a second example of a cyclic quadrilateral.

Challenge: Draw a cyclic quadrilateral with one side of length zero. What shape is this cyclic quadrilateral? Does Ptolemy's claim hold true for it?

Students will see that the relationship $AC \cdot BD = AB \cdot CD + BC \cdot AD$ seems to hold, within measuring error. For a quadrilateral with one side of length zero, the figure is a triangle inscribed in a circle. If the length $AB = 0$, then the points A and B coincide, and Ptolemy's theorem states $AC \cdot AD = 0 \cdot CD + AC \cdot AD$, which is true.

MP.7

Exploratory Challenge (30 minutes): A Journey to Ptolemy's Theorem

This Exploratory Challenge will lead students to a proof of Ptolemy's theorem. Students should work in pairs. The teacher will guide as necessary.

Exploratory Challenge: A Journey to Ptolemy's Theorem

The diagram shows cyclic quadrilateral $ABCD$ with diagonals \overline{AC} and \overline{BD} intersecting to form an acute angle with degree measure w . $AB = a$, $BC = b$, $CD = c$, and $DA = d$.

- a. From last lesson, what is the area of quadrilateral $ABCD$ in terms of the lengths of its diagonals and the angle w ? Remember this formula for later on!

$$\text{Area}(ABCD) = \frac{1}{2} AC \cdot BD \cdot \sin w$$

- b. Explain why one of the angles, $\angle BCD$ or $\angle BAD$, has a measure less than or equal to 90° .

Opposite angles of a cyclic quadrilateral are supplementary. These two angles cannot both have measures greater than 90° .

- c. Let's assume that $\angle BCD$ in our diagram is the angle with a measure less than or equal to 90° . Call its measure v degrees. What is the area of triangle BCD in terms of b , c , and v ? What is the area of triangle BAD in terms of a , d , and v ? What is the area of quadrilateral $ABCD$ in terms of a , b , c , d , and v ?

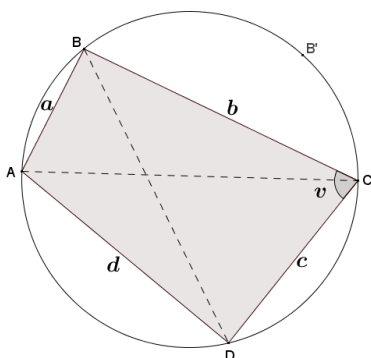
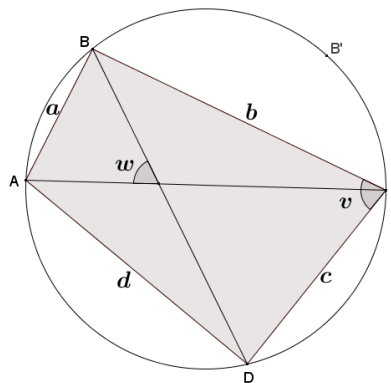

If v represents the degree measure of an acute angle, then $180 - v$ would be the degree measure of angle BAD since opposite angles of a cyclic quadrilateral are supplementary. The area of triangle BCD could then be calculated using $\frac{1}{2} bc \cdot \sin(v)$, and the area of triangle ABD could be calculated by $\frac{1}{2} ad \cdot \sin(180 - (180 - v))$, or $\frac{1}{2} ad \cdot \sin(v)$. So, the area of the quadrilateral $ABCD$ is the sum of the areas of triangles ABD and BCD , which provides the following:

$$\text{Area}(ABCD) = \frac{1}{2} ad \cdot \sin v + \frac{1}{2} bc \cdot \sin v.$$

Scaffolding:

- For part (c) of the Exploratory Challenge, review Exercises 4 and 5 from Lesson 20 which show that the area formula for a triangle, $\text{Area}(ABC) = \frac{1}{2} ab \sin(c)$, can be used where c represents an obtuse angle with a targeted small group.
- Allow advanced learners to work through and struggle with the exploration on their own.

- d. We now have two different expressions representing the area of the same cyclic quadrilateral $ABCD$. Does it seem to you that we are close to a proof of Ptolemy's claim?

Equating the two expressions gives us a relationship that does, admittedly, use the four side lengths of the quadrilateral and the two diagonal lengths, but we also have terms that involve $\sin(w)$ and $\sin(v)$. These terms are not part of Ptolemy's equation.

In order to reach Ptolemy's conclusion, in Exploratory Challenge, parts (e)–(j), students will use rigid motions to convert the cyclic quadrilateral $ABCD$ to a new cyclic quadrilateral of the same area with the same side-lengths (but in an alternative order) and with its matching angle v congruent to angle w in the original diagram. Equating the areas of these two cyclic quadrilaterals will yield the desired result. Again, have students complete this work in homogeneous pairs or small groups. Offer to help students as needed.

Scaffolding:

The argument provided in part (e), (ii) follows the previous lesson. An alternative argument is that the perpendicular bisector of a chord of a circle passes through the center of the circle. Reflecting a circle or points on a circle about the perpendicular bisector of the chord is, therefore, a symmetry of the circle; thus, B must go to a point B' on the same circle.

- e. Trace the circle and points $A, B, C,$ and D onto a sheet of patty paper. Reflect triangle ABC about the perpendicular bisector of diagonal \overline{AC} . Let $A', B',$ and C' be the images of the points $A, B,$ and $C,$ respectively.

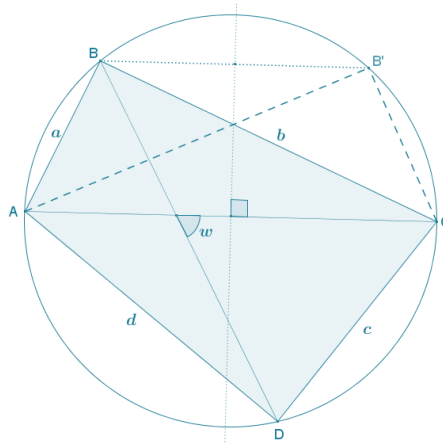

- i. What does the reflection do with points A and C ?
Because the reflection was done about the perpendicular bisector of the chord \overline{AC} , the endpoints of the chord are images of each other; i.e., $A = C'$ and $C = A'$.
- ii. Is it correct to draw B' as on the circle? Explain why or why not.
Reflections preserve angle measure. Thus, $\angle AB'C \cong \angle ABC$. Also, $\angle ABC$ is supplementary to $\angle CDA$. Thus, $\angle AB'C$ is, too. This means that $AB'CD$ is a quadrilateral with one pair (and, hence, both pairs) of opposite angles supplementary. Therefore, it is cyclic. This means that B' lies on the circle that passes through $A, C,$ and D . And this is the original circle.
- iii. Explain why quadrilateral $AB'CD$ has the same area as quadrilateral $ABCD$.
Triangle $AB'C$ is congruent to triangle ABC by a congruence transformation, so these triangles have the same area. It now follows that the two quadrilaterals have the same area.

- f. The diagram shows angles having degree measures $u, w, x, y,$ and z . Find and label any other angles having degree measures $u, w, x, y,$ or z , and justify your answers.

See diagram. Justifications include the inscribed angle theorem and vertical angles.

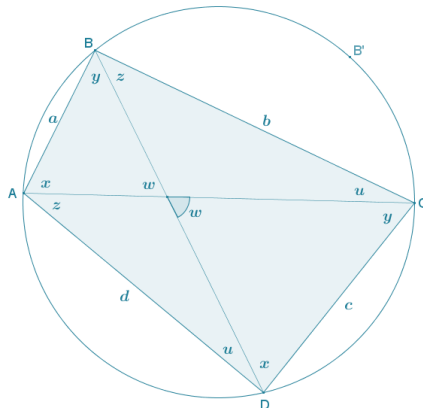

- g. Explain why $w = u + z$ in your diagram from part (f).
 The angle with degree measure w is an exterior angle to a triangle with two remote interior angles u and z . It follows that $w = u + z$.
- h. Identify angles of measures $u, x, y, z,$ and w in your diagram of the cyclic quadrilateral $AB'CD$ from part (e). See diagram below.

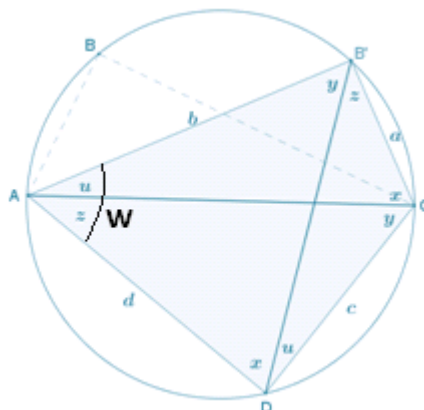

- i. Write a formula for the area of triangle $B'AD$ in terms of $b, d,$ and w . Write a formula for the area of triangle $B'CD$ in terms of $a, c,$ and w .
- $\text{Area}(B'AD) = bd \cdot \sin(w)$
 and
 $\text{Area}(B'CD) = ac \cdot \sin(w)$
- j. Based on the results of part (i), write a formula for the area of cyclic quadrilateral $ABCD$ in terms of $a, b, c, d,$ and w .
- $\text{Area}(ABCD) = \text{Area}(AB'CD) = \frac{1}{2}bd \cdot \sin(w) + \frac{1}{2}ac \cdot \sin(w)$

k. Going back to part (a), now establish Ptolemy's theorem.

$$\frac{1}{2} AC \cdot BD \cdot \sin(w) = \frac{1}{2} bd \cdot \sin(w) + \frac{1}{2} ac \cdot \sin(w) \quad \text{The two formulas represent the same area.}$$

$$\frac{1}{2} \cdot \sin(w) \cdot (AC \cdot BD) = \frac{1}{2} \cdot \sin(w) \cdot (bd + ac) \quad \text{Distributive property}$$

$$AC \cdot BD = bd + ac \quad \text{Multiplicative property of equality}$$

or

$$AC \cdot BD = (BC \cdot AD) + (AB \cdot CD) \quad \text{Substitution}$$

Closing (3 minutes)

Gather the class together and ask the following questions:

- What was most challenging in your work today?
 - *Answers will vary. Students might say that it was challenging to do the algebra involved or to keep track of congruent angles, for example.*
- Are you convinced that this theorem holds for all cyclic quadrilaterals?
 - *Answers will vary, but students should say "yes."*
- Will Ptolemy's theorem hold for all quadrilaterals? Explain.
 - *At present, we don't know! The proof seemed very specific to cyclic quadrilaterals, so we might suspect it holds only for these types of quadrilaterals. (If there is time, students can draw an example of non-cyclic quadrilateral and check that the result does not hold for it.)*

Lesson Summary

Theorems

PTOLEMY'S THEOREM: For a cyclic quadrilateral $ABCD$, $AC \cdot BD = AB \cdot CD + BC \cdot AD$.

Relevant Vocabulary

CYCLIC QUADRILATERAL: A quadrilateral with all vertices lying on a circle is known as a *cyclic quadrilateral*.

Exit Ticket (5 minutes)

Name _____

Date _____

Lesson 21: Ptolemy's Theorem

Exit Ticket

What is the length of the chord \overline{AC} ? Explain your answer.

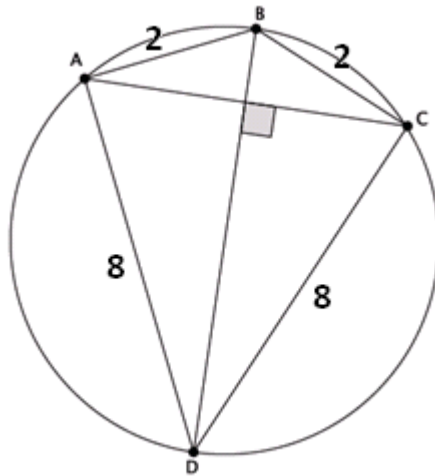

Exit Ticket Sample Solutions

What is the length of the chord \overline{AC} ? Explain your answer.

Chord \overline{BD} is a diameter of the circle, and $BD = \sqrt{2^2 + 8^2} = \sqrt{68}$. By Ptolemy's theorem: $AC \cdot \sqrt{68} = 2 \cdot 8 + 2 \cdot 8$, giving $AC = \frac{32}{\sqrt{68}}$.

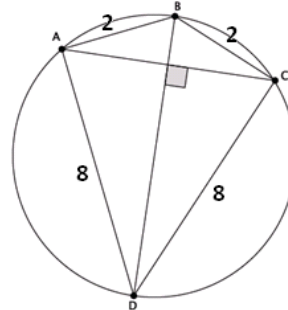

Problem Set Sample Solutions

1. An equilateral triangle is inscribed in a circle. If P is a point on the circle, what does Ptolemy's theorem have to say about the distances from this point to the three vertices of the triangle?

It says that the sum of the two shorter distances is equal to the longer distance.

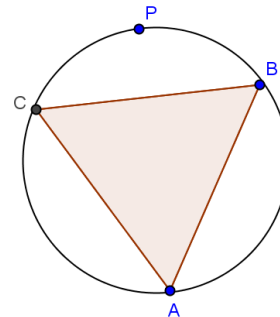

2. Kite $ABCD$ is inscribed in a circle. The kite has an area of 108 sq. in., and the ratio of the lengths of the non-congruent adjacent sides is 3 : 1. What is the perimeter of the kite?

$$\frac{1}{2} AC \cdot BD = 108$$

$$AC \cdot BD = AB \cdot CD + BC \cdot AD = 216$$

Since $AB = BC$ and $AD = CD$, then

$$AC \cdot BD = AB \cdot CD + AB \cdot CD = 2AB \cdot CD = 216$$

$$AB \cdot CD = 108.$$

Let x be the length of CD , then

$$x \cdot 3x = 108$$

$$3x^2 = 108$$

$$x^2 = 36$$

$$x = 6.$$

The length $CD = AD = 6$, and the length $AB = BC = 18$. Therefore, the perimeter of kite $ABCD$ is 48 in.

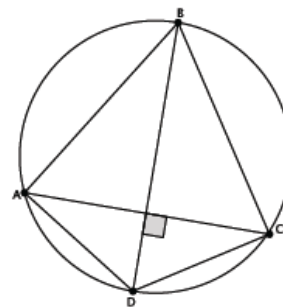

3. Draw a right triangle with leg lengths a and b , and hypotenuse length c . Draw a rotated copy of the triangle such that the figures form a rectangle. What does Ptolemy have to say about this rectangle?

We get $a^2 + b^2 = c^2$, the Pythagorean theorem!

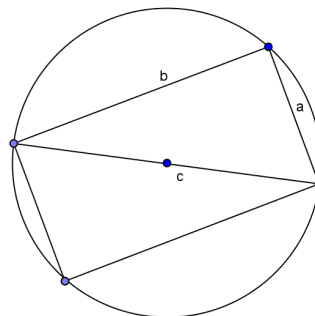

4. Draw a regular pentagon of side length 1 in a circle. Let b be the length of its diagonals. What does Ptolemy's theorem say about the quadrilateral formed by four of the vertices of the pentagon?

$b^2 = b + 1$, so $b = \frac{\sqrt{5}+1}{2}$. (This is the famous golden ratio!)

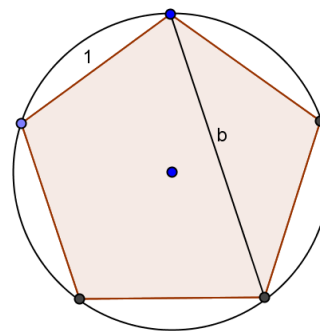

5. The area of the inscribed quadrilateral is $\sqrt{300}$ mm². Determine the circumference of the circle.

Since $ABCD$ is a rectangle, then $AD \cdot AB = \sqrt{300}$, and the diagonals are diameters of the circle.

The length of $AB = 2r \sin 60$, and the length of $BC = 2r \sin 30$, so

$$\frac{AB}{AD} = \sqrt{3}, \text{ and } AB = \sqrt{3}(AD).$$

$$AD \cdot \sqrt{3}(AD) = \sqrt{300}$$

$$AD^2 = 100$$

$$AD = 10$$

$$AB = 10\sqrt{3}$$

$$AB \cdot DC + AD \cdot BC = AC \cdot BD$$

$$10\sqrt{3} \cdot 10\sqrt{3} + 10 \cdot 10 = AC \cdot AC$$

$$300 + 100 = AC^2$$

$$400 = AC^2$$

$$20 = AC$$

Since $AC = 20$, the radius of the circle is 10, and the circumference of the circle is 20π mm.

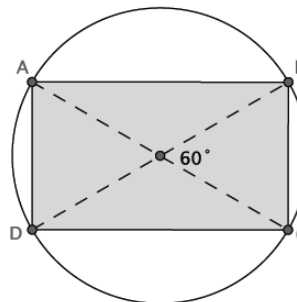

6. Extension: Suppose x and y are two acute angles, and the circle has a diameter of 1 unit. Find a , b , c , and d in terms of x and y . Apply Ptolemy's theorem, and determine the exact value of $\sin(75^\circ)$.

Use scaffolded questions below as needed.

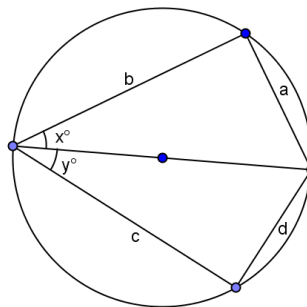

a. Explain why $\frac{a}{\sin(x)}$ equals the diameter of the circle.

If the diameter is 1, this is a right triangle because it is inscribed in a semicircle, so $\sin(x) = \frac{a}{1}$ or the $1 = \frac{a}{\sin(x)}$. Since the diameter is 1, the diameter is equal to $\frac{a}{\sin(x)}$.

b. If the circle has a diameter of 1, what is a ?

$a = \sin(x)$

c. Use Thales' theorem to write the side lengths in the original diagram in terms of x and y .

Since both are right triangles, the side lengths are $a = \sin(x)$, $b = \cos(x)$, $c = \cos(y)$, and $d = \sin(y)$.

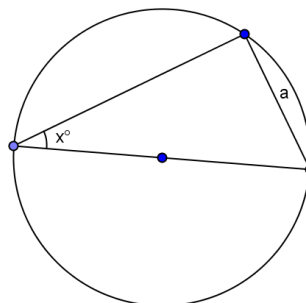

d. If one diagonal of the cyclic quadrilateral is 1, what is the other?

$\sin(x + y)$

e. What does Ptolemy's theorem give?

$1 \cdot \sin(x + y) = \sin(x)\cos(y) + \cos(x)\sin(y)$

f. Using the result from part (e), determine the exact value of $\sin(75^\circ)$.

$$\sin(75) = \sin(30 + 45) = \sin(30)\cos(45) + \cos(30)\sin(45) = \frac{1}{2} \cdot \frac{\sqrt{2}}{2} + \frac{\sqrt{3}}{2} \cdot \frac{\sqrt{2}}{2} = \frac{\sqrt{2} + \sqrt{6}}{4}$$

- c. What is the area of the portion of the interior of the circle that lies in the second quadrant? (Give an approximate answer correct to one decimal place.)
- d. What is the length of the arc of the circle that lies in the first quadrant with endpoints on the axes? (Give an exact answer in terms of π .)
- e. What is the length of the arc of the circle that lies in the second quadrant with endpoints on the axes? (Give an approximate answer correct to one decimal place.)

- f. A line of slope -1 is tangent to the circle with point of contact in the first quadrant. What are the coordinates of that point of contact?
- g. Describe a sequence of transformations that show circle C is similar to a circle with radius one centered at the origin.
- h. If the same sequence of transformations is applied to the tangent line described in part (f), will the image of that line also be a line tangent to the circle of radius one centered about the origin? If so, what are the coordinates of the point of contact of this image line and this circle?

2. In the figure below, the circle with center O circumscribes $\triangle ABC$.

Points A , B , and P are collinear, and the line through P and C is tangent to the circle at C . The center of the circle lies inside $\triangle ABC$.

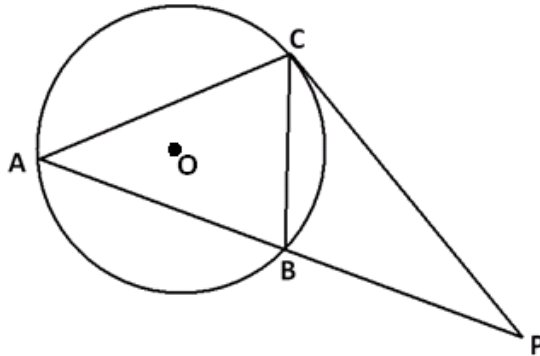

a. Find two angles in the diagram that are congruent, and explain why they are congruent.

b. If B is the midpoint of \overline{AP} and $PC = 7$, what is PB ?

- c. If $m\angle BAC = 50^\circ$, and the measure of the arc AC is 130° , what is $m\angle P$?

3. The circumscribing circle and the inscribed circle of a triangle have the same center.

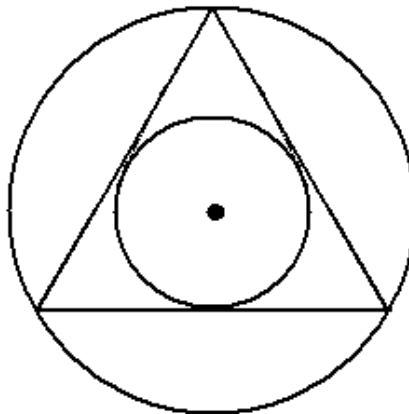

- a. By drawing three radii of the circumscribing circle, explain why the triangle must be equiangular and, hence, equilateral.

- b. Prove again that the triangle must be equilateral, but this time by drawing three radii of the inscribed circle.
- c. Describe a sequence of straightedge and compass constructions that allows you to draw a circle inscribed in a given equilateral triangle.

4.
a. Show that

$$(x - 2)(x - 6) + (y - 5)(y + 11) = 0$$

is the equation of a circle. What is the center of this circle? What is the radius of this circle?

- b. A circle has diameter with endpoints (a, b) and (c, d) . Show that the equation of this circle can be written as

$$(x - a)(x - b) + (y - c)(y - d) = 0.$$

5. Prove that opposite angles of a cyclic quadrilateral are supplementary.

A Progression Toward Mastery

Assessment Task Item	STEP 1 Missing or incorrect answer and little evidence of reasoning or application of mathematics to solve the problem.	STEP 2 Missing or incorrect answer but evidence of some reasoning or application of mathematics to solve the problem.	STEP 3 A correct answer with some evidence of reasoning or application of mathematics to solve the problem, or an incorrect answer with substantial evidence of solid reasoning or application of mathematics to solve the problem.	STEP 4 A correct answer supported by substantial evidence of solid reasoning or application of mathematics to solve the problem.	
1	a G-GPE.A.1	Student shows no understanding of finding the center of the circle.	Student attempts to find the diameter of the circle, but finds it incorrectly.	Student finds the correct diameter of the circle, but does not find center.	Student finds the coordinates of the center of the circle correctly.
	b G-C.B.5 G-GPE.B.4	Student shows no understanding of finding the area of the region.	Student finds the area of the entire circle correctly, but does not find the area of the shaded region.	Student finds the area of the shaded region, but not in terms of pi.	Student correctly finds the area of the shaded region in terms of pi.
	c G-C.B.5	Student shows no understanding of finding the area of the region in the second quadrant.	Student finds the area of the entire circle, but not the region in the second quadrant.	Student finds the area of the circle in the second quadrant, but does not round correctly.	Student correctly finds the area of the circle in the second quadrant.
	d G-C.A.2	Student shows no understanding of finding the length of an arc of a circle.	Student finds the length of an arc, but it is not in the first quadrant.	Student finds the length of the arc in the first quadrant, but not in terms of pi.	Student correctly finds the length of the arc in the first quadrant in terms of pi.
	e G-C.A.2	Student shows no understanding of finding the length of an arc of a circle.	Student finds the length of an arc, but it is not in the second quadrant.	Student finds the length of the arc in the second quadrant, but does not round correctly.	Student correctly finds the length of the arc in the second quadrant.
	f G-GPE.A.1	Student shows no knowledge of tangent lines to a circle.	Student shows some understanding of the relationship between a tangent line and the radius.	Student correctly writes the equation of the tangent line and the circle, but makes a mathematical error in solving for the point of contact.	Student finds the coordinates of the point of contact correctly with supporting work.

	g G-C.A.1	Student shows no knowledge of transformations or circle similarity.	Student shows some knowledge of transformations and circle similarity.	Student translates the circle, but does not dilate or dilates but does not translate.	Student correctly describes the translation and dilation of the circle.
	h G-GPE.A.1 G-GPE.B.4	Student shows no knowledge of transformations or circle similarity.	Student states that the circle and tangent line will still touch at one point, but does not attempt to find the new point or states that it is the same point in part (g).	Student states that the circle and tangent line will still touch and attempts to find the new point, but makes a mathematical mistake.	Student states that the circle and tangent line will still touch and correctly finds the coordinates of the new point.
2	a G-C.A.2	Student shows little or no understanding of inscribed and central angles and their relationships.	Student shows some understanding of inscribed and central angles and their relationships but does not find congruent angles.	Student finds two congruent angles, but does not explain their congruence accurately.	Student finds two congruent angles and explains their congruence accurately.
	b G-C.A.2	Student does not identify similar triangles and makes little progress with this question.	Student identifies similar triangles, but does not use the ratio of the sides to determine segment length.	Student identifies similar triangles and sets up the ratio of sides, but a mathematical mistake leads to an incorrect answer.	Student uses similar triangles and the ratio of sides to find the correct segment length.
	c G-C.A.2	Student shows little or no understanding of inscribed and central angles and their relationships.	Student shows some understanding of inscribed and central angles, but does not use the secant/tangent theorem to find the angle measure.	Student shows an understanding of inscribe and central angles and the secant/tangent theorem, but does not arrive at the correct angle measure.	Student shows an understanding of inscribe and central angles and the secant/tangent theorem, but arrives at the correct angle measure.
3	a G-C.A.3	Student shows little or no understanding an inscribed triangle.	Student draws the correct radii of the circumscribing circle, but cannot explain why the triangle is equilateral.	Student identifies base angles of an isosceles triangle as congruent, and recognizes that the radii are angle bisectors of the triangle, but does not prove the triangle is equilateral.	Student identifies base angles of an isosceles triangle as congruent, recognizes that the radii are angle bisectors, and uses those relationships to prove the triangle is equilateral.
	b G-C.A.3	Student shows little or no understanding an inscribed circle.	Student draws the correct radii of the inscribed circle, but cannot explain why the triangle is equilateral.	Student recognizes that the radii are perpendicular bisectors of the sides of the triangle, but does not prove the triangle is equilateral.	Student recognizes that the radii are perpendicular bisectors of the sides of the triangle, and uses the two tangent theorem to prove the triangle is equilateral.

	c G-C.A.3	Student does not recognize angle bisectors or perpendicular bisectors and makes little progress on the proof. Student does not describe a suitable construction process.	Student recognizes just the angle bisectors or just the perpendicular bisectors needed to complete the proof. Student makes some progress for describing a suitable construction process.	Student recognizes the angle bisectors and perpendicular bisectors and makes progress towards completing the proof. Student makes good progress towards describing a complete construction process.	Student recognizes the angle bisectors and perpendicular bisectors and provides a well-articulated proof. Student also gives a complete description of a construction process.
4	a G-GPE.A.1	Student does not complete the square correctly and does not interpret the center and radius from the equation obtained.	Student attempts to complete the square, but makes mathematical mistakes leading to incorrect answers for both center and radius.	Student confuses the signs of the coordinates of the center or fails to give the square root of the quantity for the radius after conducting the correct algebraic.	Student finds correct center and radius with supporting work.
	b G-GPE.A.1	Student does not find the center or the radius of the circle.	Student finds the center and radius of the circle correctly but does not transform the equation.	Student writes the equation of the circle using the coordinates of the center and the radius, but mathematical mistakes lead to an incorrect answer.	Student writes the equation of the circle using the coordinates of the center and the radius, and shows the steps to transform the equation into the stated form.
5	G-C.A.3	Student does not set up a suitable scenario for constructing the proof.	Student describes a potentially suitable scenario for constructing a proof but does not complete the proof.	Student makes some good progress for establishing a proof with only minor inconsistencies in reasoning or explanation.	Student provides a thorough and elegant proof.

Name _____

Date _____

1. Let C be the circle in the coordinate plane that passes through the points $(0, 0)$, $(0, 6)$, and $(8, 0)$.
 - a. What are the coordinates of the center of the circle?

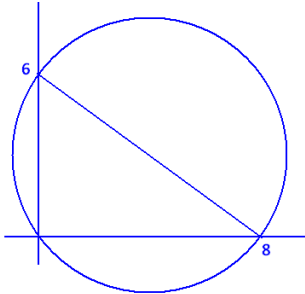

Since the angle formed by the points $(0, 6)$, $(0, 0)$, and $(8, 0)$ is a right angle, the line segment connecting $(0, 6)$ to $(8, 0)$ must be the diameter of the circle. Therefore, the center of the circle is $(4, 3)$, the midpoint of this diameter.

- b. What is the area of the portion of the interior of the circle that lies in the first quadrant? (Give an exact answer in terms of π .)

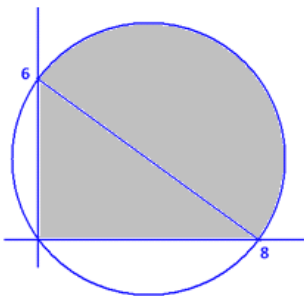

The distance between $(0, 6)$ and $(8, 0)$ is $\sqrt{6^2 + 8^2} = 10$, so the circle has radius 5. The area in question is composed of half a circle and a right triangle.

Its area is $\left(\frac{1}{2} \times 8 \times 6\right) + \left(\frac{1}{2} \pi 5^2\right) = \frac{25\pi}{2} + 24$ square units.

- c. What is the area of the portion of the interior of the circle that lies in the second quadrant? (Give an approximate answer correct to one decimal place.)

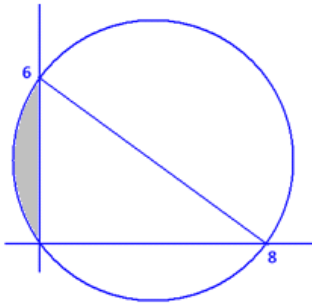

We seek the area of the region shown. We have a chord of length 6 in a circle of radius 5.

Label the angle x as shown and distance d . By the Pythagorean theorem,

$d = 4$. We also have that $\sin(x) = \frac{3}{5}$, so $x \approx 36.9^\circ$.

The shaded area is the difference of the area of a sector and of a triangle. We have

$$\text{area} = \left(\frac{2x}{360}\pi 5^2\right) - \left(\frac{1}{2} \times 6 \times 4\right) \approx \left(\frac{73.8}{360} \times 25\pi\right) - 12 \approx 4.1 \text{ square units.}$$

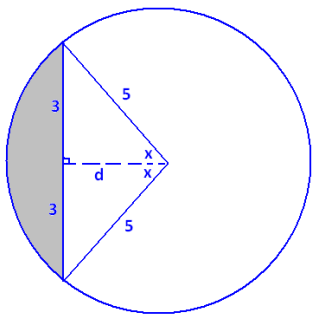

- d. What is the length of the arc of the circle that lies in the first quadrant with endpoints on the axes? (Give an exact answer in terms of π .)

Since this arc is a semicircle, it is half the circumference of the circle in length:

$$\frac{1}{2} \times 2\pi \times 5 = 5\pi \text{ units.}$$

- e. What is the length of the arc of the circle that lies in the second quadrant with endpoints on the axes? (Give an approximate answer correct to one decimal place.)

Using the notation of part (c), this length is $\frac{2x}{360} \cdot 2\pi \cdot 5 \approx \frac{73.8}{360} \times 10\pi \approx 6.4$ units.

- f. A line of slope -1 is tangent to the circle with point of contact in the first quadrant. What are the coordinates of that point of contact?

Draw a radius from the center of the circle, $(4, 3)$, to the point of contact, which we will denote (x, y) .

This radius is perpendicular to the tangent line and has slope 1 . Consequently, $\frac{y-3}{x-4} = 1$; that is, $y - 3 = x - 4$.

Also, since (x, y) lies on the circle, we have

$$(x - 4)^2 + (y - 3)^2 = 25.$$

For both equations to hold, we must have

$(x - 4)^2 + (x - 4)^2 = 25$, giving $x = 4 + \frac{5}{\sqrt{2}}$, or $x = 4 - \frac{5}{\sqrt{2}}$. It is clear from the diagram that the point of contact we seek has its x -coordinate to the right of the x -coordinate of the center of the circle. So, choose $x = 4 + \frac{5}{\sqrt{2}}$. The matching y -coordinate is $y = x - 4 + 3 = x - 1 = 3 + \frac{5}{\sqrt{2}}$, so the point of contact has coordinates $\left(4 + \frac{5}{\sqrt{2}}, 3 + \frac{5}{\sqrt{2}}\right)$.

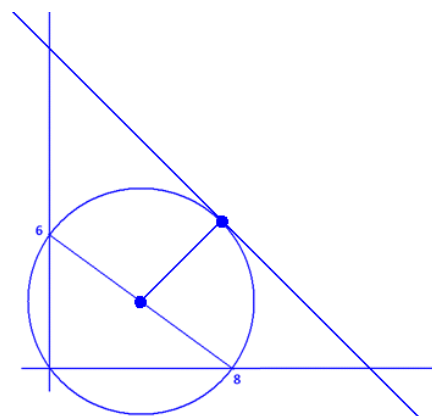

- g. Describe a sequence of transformations that show circle C is similar to a circle with radius one centered at the origin.

Circle C has center $(4, 3)$ and radius 5 .

First, translate the circle four units to the left and three units downward. This gives a congruent circle with the origin as its center. (The radius is still 5 .)

Perform a dilation from the origin with scale factor $\frac{1}{5}$. This will produce a similar circle centered at the origin with radius 1 .

- h. If the same sequence of transformations is applied to the tangent line described in part (f), will the image of that line also be a line tangent to the circle of radius one centered about the origin? If so, what are the coordinates of the point of contact of this image line and this circle?

Translations and dilations map straight lines to straight lines. Thus, the tangent line will still be mapped to a straight line. The mappings will not alter the fact that the circle and the line touch at one point. Thus, the image will again be a line tangent to the circle.

Under the translation described in part (i), the point of contact, $\left(4 + \frac{5}{\sqrt{2}}, 3 + \frac{5}{\sqrt{2}}\right)$, is mapped to $\left(\frac{5}{\sqrt{2}}, \frac{5}{\sqrt{2}}\right)$. Under the dilation described, this is then mapped to $\left(\frac{1}{\sqrt{2}}, \frac{1}{\sqrt{2}}\right)$.

2. In the figure below, the circle with center O circumscribes $\triangle ABC$.

Points A , B , and P are collinear, and the line through P and C is tangent to the circle at C . The center of the circle lies inside $\triangle ABC$.

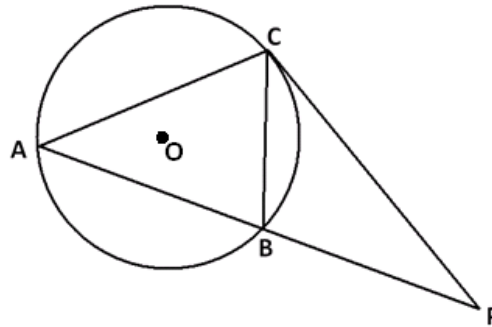

- a. Find two angles in the diagram that are congruent, and explain why they are congruent.

Draw two radii as shown. Let $m\angle BAC = x$. Then by the inscribed/central angle theorem, we have $m\angle BOC = 2x$.

Since $\triangle BOC$ is isosceles, it follows that $m\angle OCB = \frac{1}{2}(180^\circ - 2x) = 90^\circ - x$.

By the radius/tangent theorem, $m\angle OCP = 90^\circ$, so $m\angle BCP = x$.

We have $\angle BAC \cong \angle BCP$ because they intercept the same arc and have the same measure.

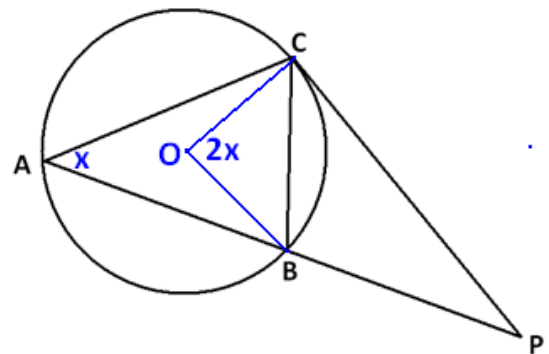

- b. If B is the midpoint of \overline{AP} and $PC = 7$, what is PB ?

By the previous question, triangles ACP and CBP each have an angle of measure x and share the angle at P . Thus, they are similar triangles.

Since triangles ACP and CBP are similar, matching sides come in the same ratio. Thus, $\frac{PB}{PC} = \frac{PC}{AP}$. Now, $AP = 2 \cdot PB$, and $PC = 7$, so $\frac{PB}{7} = \frac{7}{2PB}$. This gives $PB = \frac{7}{\sqrt{2}}$.

- c. If $m\angle BAC = 50^\circ$, and the measure of the arc AC is 130° , what is $m\angle P$?

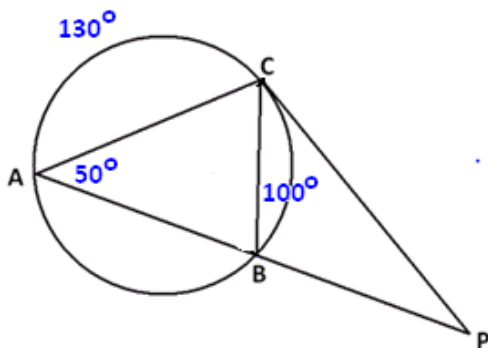

By the inscribed/central angle theorem, arc BC has measure 100° . By the secant/tangent angle theorem,

$$m\angle P = \frac{130^\circ - 100^\circ}{2} = 15^\circ.$$

(One can also draw in radii and chase angles in triangles to obtain the same result.)

3. The circumscribing circle and the inscribed circle of a triangle have the same center.

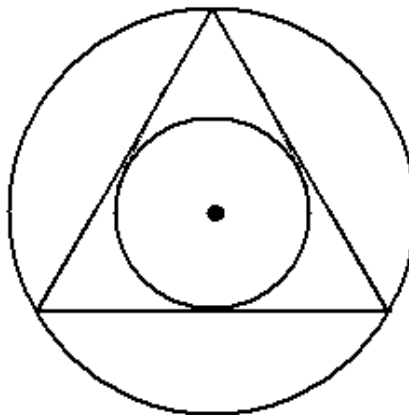

- a. By drawing three radii of the circumscribing circle, explain why the triangle must be equiangular and, therefore, equilateral.

Draw the three radii as directed, and label six angles $a, b, c, d, e,$ and f as shown.

We have $a = f$ because they are base angles of an isosceles triangle. (We have congruent radii.) In the same way, $b = c$ and $d = e$.

From the construction of an inscribed circle, we know that each radius drawn is an angle bisector of the triangle. Thus, we have $a = b, c = d,$ and $e = f$.

It now follows that $a = b = c = d = e = f$. In particular, $a + b = c + d = e + f$, and the triangle is equiangular. Therefore, they are equilateral.

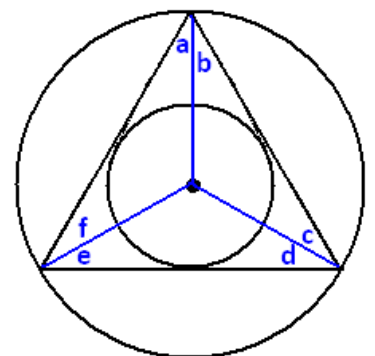

- b. Prove again that the triangle must be equilateral, but this time by drawing three radii of the inscribed circle.

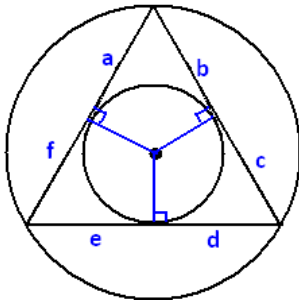

By the construction of the circumscribing circle of a triangle, each radius in this picture is the perpendicular bisector of a side of the triangle. If we label the lengths a , b , c , d , e , and f as shown, it follows that $b = c$, $d = e$, and $a = f$.

By the two-tangents theorem, we also have $a = b$, $c = d$, and $e = f$.

Thus, $a = b = c = d = e = f$, and, in particular, $b + c = d + e = a + f$; therefore, the triangle is equilateral.

- c. Describe a sequence of straightedge and compass constructions that allows you to draw a circle inscribed in a given equilateral triangle.

The center of an inscribed circle lies at the point of intersection of any two angle bisectors of the equilateral triangle.

To construct an angle bisector:

1. Draw a circle with center at one vertex P of the triangle intersecting two sides of the triangle. Call those two points of intersection A and B .
2. Setting the compass at a fixed width, draw two congruent intersecting circles, one centered at A and one centered at B . Call a point of intersection of these two circles Q . (We can assume Q is different from P .)
3. The line through P and Q is an angle bisector of the triangle.

Next, construct two such angle bisectors and call their point of intersection O . This is the center of the inscribed circle. Finally, draw a line through O perpendicular to one side of the triangle.

To do this:

1. Draw a circle centered at O that intersects one side of the triangle at two points. Call those points C and D .
2. Draw two congruent intersecting circles, one with center C and one with center D .
3. Draw the line through the points of intersection of those two congruent circles. This is a line through O perpendicular to the side of the triangle.

Suppose this perpendicular line through O intersects the side of the triangle at the point R . Set the compass to have width equal to OR . This is the radius of the inscribed circle; so, drawing a circle of this radius with center O produces the inscribed circle.

4.
a. Show that

$$(x - 2)(x - 6) + (y - 5)(y + 11) = 0$$

is the equation of a circle. What is the center of this circle? What is the radius of this circle?

We have

$$\begin{aligned}(x - 2)(x - 6) + (y - 5)(y + 11) &= 0 \\ x^2 - 8x + 12 + y^2 + 6y - 55 &= 0 \\ x^2 - 8x + 16 + y^2 + 6y + 9 &= 4 + 64 \\ (x - 4)^2 + (y + 3)^2 &= 68.\end{aligned}$$

This is the equation of a circle with center $(4, -3)$ and radius $\sqrt{68}$.

- b. A circle has diameter with endpoints (a, b) and (c, d) . Show that the equation of this circle can be written as

$$(x - a)(x - b) + (y - c)(y - d) = 0.$$

The midpoint of the diameter, which is $\left(\frac{a+c}{2}, \frac{b+d}{2}\right)$, is the center of the circle; half the distance between the endpoints, which is $\frac{1}{2}\sqrt{(c-a)^2 + (d-b)^2}$, is the radius of the circle. Thus, the equation of the circle is

$$\left(x - \frac{a+c}{2}\right)^2 + \left(y - \frac{b+d}{2}\right)^2 = \frac{1}{4}((c-a)^2 + (d-b)^2).$$

Multiplying through by 4 gives

$$(2x - a - c)^2 + (2y - b - d)^2 = (c - a)^2 + (d - b)^2.$$

This becomes

$$4x^2 + a^2 + c^2 - 4xa - 4xc + 2ac + 4y^2 + b^2 + d^2 - 4yb - 4yd + 2bd = c^2 + a^2 - 2ac + d^2 + b^2 - 2bd.$$

That is,

$$4x^2 - 4xa - 4xc + 4ac + 4y^2 - 4yb - 4yd + 4bd = 0.$$

Dividing through by 4 gives

$$x^2 - xa - xc + ac + y^2 - yb - yd + bd = 0.$$

That is,

$$(x - a)(x - c) + (y - b)(y - d) = 0,$$

as desired.

5. Prove that opposite angles of a cyclic quadrilateral are supplementary.

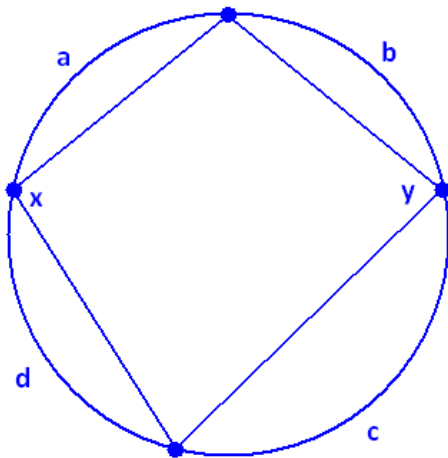

Consider a cyclic quadrilateral with two interior opposite angles of measures x and y , as shown.

The vertices of the quadrilateral divide the circle into four arcs. Suppose these arcs have measures a , b , c , and d , as shown.

By the inscribed/central angle theorem, we have $a + d = 2y$ and $b + c = 2x$. So, $a + b + c + d = 2(x + y)$.

But, $a + b + c + d = 360^\circ$. Thus, it follows that $x + y = \frac{360^\circ}{2} = 180^\circ$.

By analogous reasoning, the angles in the second pair of interior opposite angles are supplementary as well. (This also follows from the fact that the interior angles of a quadrilateral add to 360° . The second pair of interior angles have measures adding to $360^\circ - x - y = 360^\circ - 180^\circ = 180^\circ$.)